

tomorrow

EXPERIENCING TECHNOLOGY WITH SCHAEFFLER



Motion²

Increasingly electric, digital, fast – technological transformation doesn't skip a beat

Ac|cel|er|a|tion [ak,selə'rāSHən]

- 1a)** the act or process of moving faster or happening more quickly; the act or process of accelerating
- b)** ability to accelerate

- 2)** *physics:* the rate of change of velocity with respect to time
broadly: change of velocity

Source: acceleration, 2018. In Merriam-Webster.com
Retrieved December 3, 2018, from <https://www.merriam-webster.com/dictionary/acceleration>



DEAR READER,

Time flies – a phenomenon that’s particularly noticeable as the year draws to a close. The past 365 days? Flashed by like a fast train. Inexorably. Plus, technological progress – spearheaded by digital transformation – seems to further accelerate the ticking of the clock. Be it data transfer or train travel – anything that’s slower than high speed is regarded as a lame duck. Even when it comes to finding a partner or to recruiting new employees, “speed dating” events are in vogue. Still, we might add, because artificial intelligence systems fed with algorithms are able to hit the bull’s eye here much faster and with greater accuracy.

So it stands to reason that if new technologies accelerate everything we should actually have a lot more time – albeit, subjectively, quite the opposite is true. The editors of our technology magazine “tomorrow” explored the question of why that’s the case. Welcome to our new issue focused on “acceleration.”

Acceleration means a change in speed, but change itself is able to change its speed. Current mode: full throttle, not only here and there but in great breadth and depth. The result is a level of momentum that can be thrilling – or disruptive. At Schaeffler, as a globally operating technology supplier, we’re not able, nor would we want, to ignore this challenge: We want to actively accelerate change with our ideas and products and have invested a lot of work and spirit in our “Agenda 4 plus One” program going forward. To achieve the goals established in it, we not only have to become faster but more agile as well: in our processes (more on this starting on page 74) and in our thinking. When it comes to thinking, why not copy the ways of a grand master of innovation: Leonardo da Vinci. His countless flashes of genius were not a gift from heaven but the result of applying specific principles of success that are still able to accelerate thought processes today (starting on page 54).

The question of when and in what areas artificial will be able to surpass human intelligence is about thought processes as well. According to some forecasts, it’s possible that AI will be better than humans in nearly any single activity before the century is out, but even if that should be the case, no machine will in itself combine as many capabilities and skills as we do. Schaeffler is already using AI applications today and their number keeps growing. Be it Industry 4.0 (also known as Industrial IoT and smart factories) or mobility for tomorrow, be it development, manufacturing or



distribution – there’s no doubt in our minds that AI and algorithms will be running in the background of all processes rather sooner than later (starting on page 102).

However, going along with and accelerating the pace of change does not automatically mean that we’re challenging the core business we’ve built over decades completely. Our core business also includes our bearings that operate around the world. Be they tiny or weighing tons, they typically operate behind the scenes. The article starting on page 38 moves them into the spotlight.

There’s no doubt in my mind that bearings from Schaeffler will continue to be used in vehicles of the next generation and the one after that: in hypersonic aircraft for example or in submarines and trains traveling from A to B at speeds above 1,000 km/h (starting on page 106) or in autonomous cars. While they may not necessarily be faster they do have the advantage that we – relieved of the need to steer – can turn our attention to other things – like the enjoyment of idle moments that, as J. W. Goethe already knew in his day, stretch time (starting on page 96).

On that note, I’m happy that you found time to take a leisurely look at the new issue of “tomorrow.”

A handwritten signature in black ink that reads "Klaus Rosenfeld". The signature is fluid and cursive, written in a professional style.

Klaus Rosenfeld
Chief Executive Officer

global

A glimpse of the world

8

GOOD TO KNOW

Facts, figures, oddities –
a **360-degree view** of the vast field
of “acceleration”

14

FASTER SAILING

For more than 2,000 years, humans
have been digging **artificial**
waterways to get ahead

20

FULL THROTTLE

How **South Korea** accelerated its
progress from a developing to a
high-speed country

24

ADRENALINE RUSH

Scientifically proven: how and
why our brain makes us feel **the**
thrill of speed

30

SUPERHUMAN

Boundless imagination:
superheroes are the true kings
of acceleration



in motion

Innovations in the course of time

38

ULTIMATE ROUNDNESS

How **precision spheres** are made for
Schaeffler bearings that keep the
world in motion

44

TICK TOCK, TICK TOCK

Technology is making all things
faster – but why do we subjectively
have **less and less time?**

48

SMARTER BRAKING

The long history of coming to a halt:
from the self-propelled vehicle to
recuperation

54

LEARNING FROM THE BEST

Five of **Leonardo da Vinci's** success
principles that may accelerate our own
mental processes



here and now

Living with progress

60 FINE-TUNED FOR GOLD
High tech from Schaeffler helps **winter athletes** reach their goals faster

64 FAST FORWARD
The Arctic in the morning, the tropics at noon: **climatic wind tunnels** accelerate development cycles

74 REVVED UP
How Schaeffler accelerates its **processes** along the entire supply and manufacturing chain

80 ACCELERATED (E-)MOTION
Thanks to torque vectoring the **Schaeffler 4ePerformance** puts 1,200 horsepower safely on the asphalt

86 PARTICLE ACCELERATOR
At **CERN** and **DESY**, researchers delve into the microcosm of elementary particles



outlook

Technology for tomorrow

92 SPEED ACCUMULATORS
New **battery and charging technologies** are designed to accelerate electric mobility

96 LETTING GO
Autonomous vehicles: not having to drive, we can make better use of our time

102 THINKING AHEAD
When will human intelligence be surpassed by **artificial intelligence?** And what will happen then?

106 PICKING UP MOMENTUM
In the air, under water, on the railroad: **interurban mobility** puts the pedal to the metal

110 3D REVOLUTION
Milling is old school; today, more and more **products are printed** – at Schaeffler as well

114 MASTHEAD

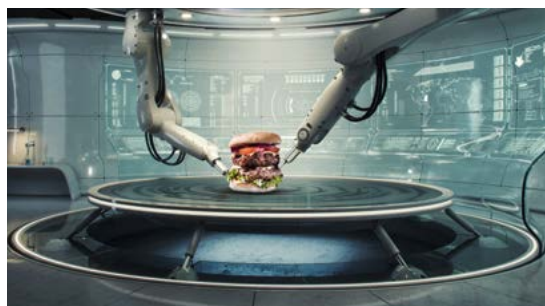

POWERED BY THE WIND

— In the middle of the 17th century, the Republic of the Seven United Netherlands had the biggest merchant fleet and navy in the world. The rise of the small nation to the level of a world power was accelerated by ingenuity, innovative technology and the efficient utilization of a renewable source of energy: wind. Calculations on windmill transmissions by Simon Stevin (1548–1620) – who due to his versatile talents is frequently referred to as the Netherlands' Leonardo da Vinci – enhanced the efficiency of the winged machines by a massive 30 percent. Cornelis Corneliszoon (1550–1600) provided the windmills tuned by Stevin with the crankshaft he had patented in 1597 that transformed the rotary motion of the windmill shaft into an oscillating motion of saw blades. This technology cut boards thirty times faster and more precisely as well than the human hand. Northwest of Amsterdam in those years, in Zaandam, Europe's first industrial area emerged with hundreds of shipyards and wind-powered sawmills. According to contemporary sources, the Dutch fleet had 16,000 ships, or 4/5 of the total European fleet. The place where the first industrial area used to be is now home to the Zaanse Schans museum complex with the reconstructed Het Jonge Schaap sawmill. —

THE BIGGEST ONES OF THEIR KIND

BY SAIL/BLADE DIAMETER



MURPHY WINDMILL

SAN FRANCISCO (USA)

Type wind pump

Completed in 1908

Sail diameter 35 meters (115 feet)

Output 151,000 l/h (40,000 gallons/h) of water



ADWEN AD 8-180 WIND TURBINE

BREMERHAVEN (D)

Type prototype of an offshore wind turbine

Completed in 2017

Blade diameter 180 meters (591 feet)

Output 8 MW of electricity



global

A glimpse of the world



» *The answer, my friend,
is blowin' in the wind* Bob Dylan



360° ACCELERATION

Facts, figures, oddities – a panoramic view
of the focus topic of this issue of “tomorrow.”

— by Björn Carstens, Volker Paulun, Alexander von Wegner

ACCELERATED ASCENT

The time it takes to climb the notorious, 1,800 meter (5,900 feet) tall Eiger north face in the Swiss Alps has been reduced in the past 80 years from 3 days to a little more than 2 hours. Even though not all climbers took the same route, it's an impressive comparison.

2015

Ueli Steck | 2 HOURS, 22 MINUTES

2007

Ueli Steck | 3 HOURS, 54 MINUTES

1983

Thomas Bubendorfer | 4 HOURS, 30 MINUTES

1981

Ueli Bühler | 8 HOURS

1974

Reinhold Messner/Peter Habeler | 10 HOURS

1950

Leo Forstenlechner/Erich Waschak | 18 HOURS

1938

Andreas Heckmair/Ludwig Vörg
Fritz Kasperek/Heinrich Harrer | 3 DAYS



SUPERTALL AT THE TIME

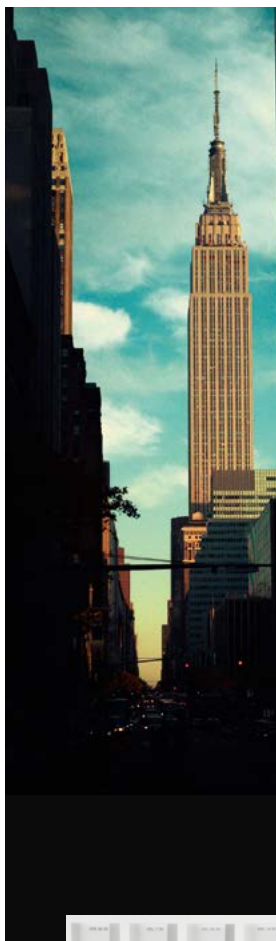

The Empire State Building was not only the first building with more than one hundred floors (102) but with a roof height of 381 meters (1,250 feet) was also the tallest building in the world from 1931 to 1972. The construction time of just one year and 45 days – accelerated by remarkable logistics and construction planning – set a record as well. Here are some facts about the construction project:

- Work on the foundation of the building began in January 1930 and was completed by March. **Erection of the building began on March 17, 1930.**
- Some **3,400 construction workers** were employed.
- Their workday began at **3.30 a.m.** and ended at **4.30 p.m.**
- Every morning, **detailed plans** were posted at the site that precisely coordinated the workflow of that day.
- Between March and September 1930, **60 stories** were erected in the shell work (overall average: 4.5 floors/week; record: 14 floors in ten days).
- The construction steel for the project came from Pennsylvania and was delivered to the site within **eight hours.**
- **Eight cranes** would lift the steel upward. Once the respective floors were finished, the cranes were dismantled and reassembled at the next higher levels.
- On some of the floors, **mobile canteens** were established for the workers and moved upward as the building kept getting taller. The price for a meal was 50 cents (hourly wage: 1,92 dollars).
- For ironwork at great heights, native Americans of the **Mohawk tribe** were preferably employed – they're regarded as being particularly fearless of heights.
- The construction costs including the site amounted to **41 million dollars** – half as much as budgeted. However, that was primarily due to the economic crisis that broke out during the construction phase.



» *We always thought of it as a parade in which each marcher kept pace and the parade marched out of the top of the building, still in perfect step. Sometimes we thought of it as a great assembly line – only the assembly line did the moving; the finished product stayed in place*

Richmond Shreve. His company Shreve, Lamb and Harmon, led the construction of the Empire State Building

2-3 BEATS/MIN.

CROCODILES ARE MASTERS OF DECELERATION AND ABLE TO REDUCE THEIR HEART RATE SO DRASTICALLY THAT THEY CAN STAY UNDER WATER UP TO ONE HOUR WITHOUT BREATHING. WHEN IT COMES TO EATING, A CROCODILE IS NOT NECESSARILY IN A HURRY EITHER. 50 FULL MEALS PER YEAR ARE PERFECTLY SUFFICIENT BECAUSE COLD-BLOODED ANIMALS ONLY CONVERT TEN PERCENT OF THE FOOD THEY EAT INTO ENERGY (MAMMALS 80%). THE REST IS DEPOSITED IN THE BODY AS FAT.



68 seconds

is all it takes 2,000 robots and 1,700 employees at the Seat plant in Martorell, Spain, to **assemble a body in white**. In doing so, they move according to a perfectly coordinated "Industry 4.0 choreography." In total, the accelerated production of a compact car like the Seat Ibiza in Martorell takes only 16 hours. Three decades ago, it was still 60 hours, in other words four times as much.



HIGH PRESSURE, SHORT COOKING TIME

This is the underlying principle of an acceleration classic: the pressure cooker.

*At 180 kPa, i.e. 1.8-fold air pressure, the boiling temperature of water is 117 °C (243 °F). According to the Le Bel-Van't Hoff rule – i.e. a temperature increase by 10 °C (50 °F) doubles the reaction time – the **cooking time would be reduced by more than half**. This is theoretical, though, and may differ depending on the type of food: Brussels sprouts cooked like this would be mushy on the outside and hard on the inside.*

CONTINUING ADVANCEMENT OF E-MOBILITY

The further development of activities in the field of electric mobility is an important pillar in Schaeffler's forward-thinking program "Agenda 4 plus One." With the acquisition of Elmotec Statomat GmbH Schaeffler extends its expertise in electric motor engineering and so consistently accelerates the implementation of its electric mobility strategy. Elmotec Statomat is one of the world's leading manufacturers of machines for high-volume production of electric motors and has unique expertise in the field of winding technology. Wave winding in particular is regarded as a leading technology in terms of power density, efficiency and efficient high-volume production going forward. Schaeffler's CEO Klaus Rosenfeld said: "This acquisition puts us in a position to seamlessly cover the entire industrialization of electric motor engineering in-house and to close the last existing technology gap in the production of rotors and stators."



Six-spindle winding machine for high-volume production of up to one million units

FROM ZERO TO 400 KM/H (249 MPH) TO ZERO IN JUST 33.29 SECONDS!

THE SWEDISH SPORTS CAR FACTORY KOENIGSEGG SET THIS ACCELERATION AND DECELERATION RECORD FOR PRODUCTION VEHICLES WITH THE AGERA RS IN THE MIDDLE OF A DESERT IN THE U.S. STATE OF NEVADA AT THE END OF 2017.



1,740.2 m
(5,709 feet)

0 km/h

400 km/h (249 mph)

0 km/h

ACCELERATION COMPARISONS



WHY DO WHIPS PRODUCE A CRACKING SOUND? ...



... WHEN SWINGING A WHIP A WAVE FORMS AT THE BEGINNING OF THE TAPERED LEATHER STRIP THAT MOVES TOWARD THE THIN END. THE CLOSER THE LOOP APPROACHES THE END THE LESS MASS IS MOVED. DUE TO THE FACT THAT THE SAME AMOUNT OF ENERGY IS MOVING LESS AND LESS MASS, THE SPEED OF THE LOOP KEEPS INCREASING UNTIL ULTIMATELY THE ENTIRE ENERGY OF THE SWUNG WHIP CONCENTRATES IN THE SMALL THIN END. THE TIP OF THE WHIP RACES THROUGH THE AIR AT TWICE THE SPEED OF SOUND IN THE PROCESS. THE TYPICAL CRACKING SOUND IS PRODUCED WHEN THE SOUND BARRIER IS BROKEN.

DIGITAL ACCELERATION

It takes a close look to detect the technical highlight of this 800-hp race car and even then a lot escapes the eye: The vehicle no longer has a mechanical steering column. Instead, the drive-by-wire specialists from Schaeffler Paravan integrated the "Space Drive" system, a multiple fail-safe digital driving and steering system to control the throttle, brake and steering. The steering inputs are transmitted via a force-feedback steering wheel developed by Paravan that's permanently integrated in the instrument panel to a computing unit that forwards the inputs to servo motors on the steering gear in real time. More about "Space Drive" and autonomous driving starting on page 96.



WORDS TO REMEMBER

» *In physics, force equals inertial mass times acceleration; in life, inertial mass without acceleration*

André Brie,
German political scientist

» *What I've learned from running is that the time to push hard is when you're hurting like crazy and you want to give up. Success is often just around the corner*

James Dyson,
founder of the Dyson Company

» *When accelerating, the tears of joy have to flow horizontally to your ear*

Racing legend Walter Röhrl

» *One year of market advantage may yield a 20-percent cost advantage*

Karl-Heinz Beckurts (1930–86),
German executive

» *There's nothing you get used to as quickly as to working slowly*

Christian Morgenstern (1871–1914),
German poet

SAFE EMERGENCY LANDING



A revolutionary idea that will save lives: Junkers Profly from Germany together with Curti Aerospace from Italy has developed a rescue system that uses a parachute to catch a crashing helicopter. The result of a test: The helicopter was retained in the right position by the parachute and hit the ground at a decelerated speed of 27 km/h (17 mph). How the system works? The rescue mechanism is activated by a small lever in the cockpit. The system sits above the rotor blades. A rocket ensures that the life-saving parachute rises fast enough to an altitude where it will unfold: an exciting innovation for drones as well.



9.81 m/s²

THE MOTHER OF ALL ACCELERATIONS ...

... *in common parlance is gravity. It's based on one of the key physical correlations that determine our life and the fate of many porcelain cups on this planet. The weight of the rotating Earth results in a force (with a large gravitational and a small centrifugal portion) that keeps all of us on the ground. It's measured in g and converted into newtons (force) per kilogram (weight). What this has to do with acceleration? That's very simple: Push a porcelain cup off a tabletop – and the precious item will be "pulled" toward the center of the Earth in free fall at 1 g. The acceleration during this process is exactly 9.81 m/s² and near-identical anywhere on the planet's surface. A short excursion into outer space: as the Moon is a lot lighter than the Earth, its gravity is six times lower – a human investing the same amount of energy could jump about eleven times higher.*

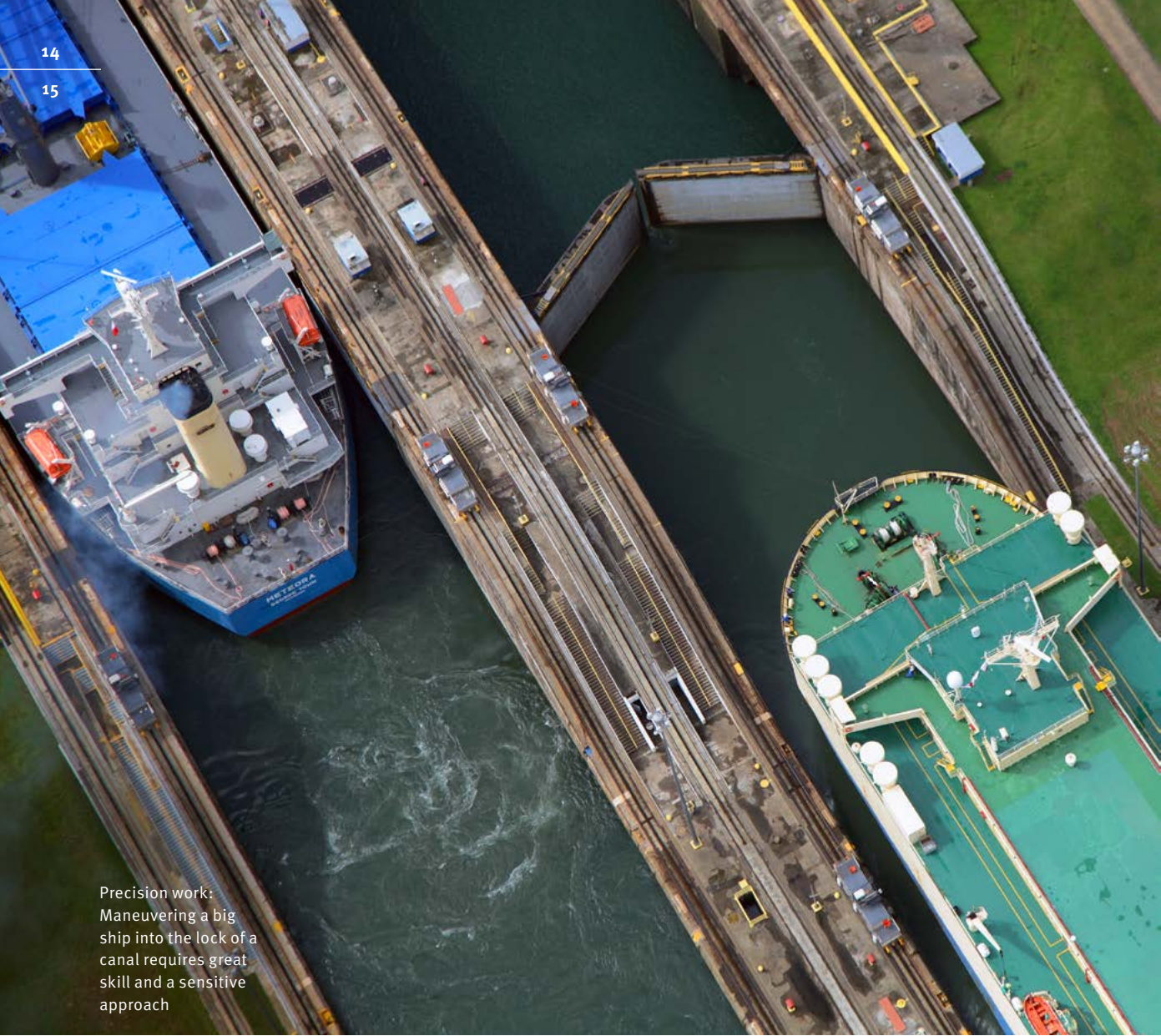

Precision work:
Maneuvering a big
ship into the lock of a
canal requires great
skill and a sensitive
approach

DIGGING FOR **GLOBALIZATION**

Long ago, canals were built strictly by human hands, helped feed the population and created the basis for rural and urban settlements. Today's waterways are miracles of technology, accelerate world trade – and, in doing so, set the pace for globalization.

— by Jan Oliver Löffken

Drawing of the Grand Canal in China from the 19th century. The waterway is clearly older, in some parts up to 2,400 years. In 984 AD, the first lock was taken into operation there as well

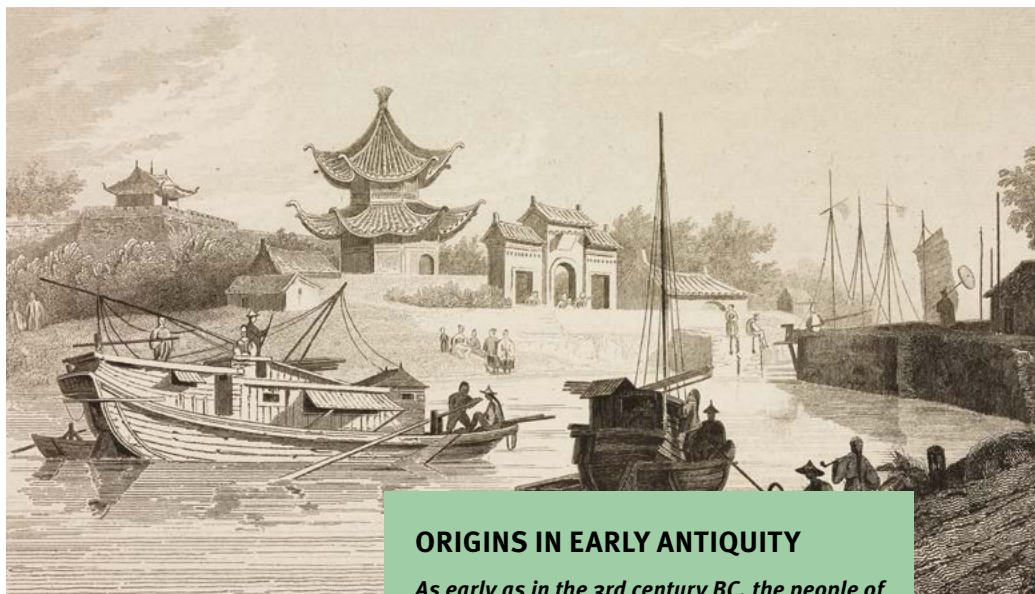

— Water has been fascinating people in a special way for millennia. Larger settlements were initially established on coasts, rivers and estuaries. However, even early civilizations complemented natural waterways by artificial ones. At first, narrow canals secured the irrigation of fields, soon to be followed by wider, navigable waterways as safe and lucrative trade routes. Rivers were connected to each other or even circumnavigated, very long ocean routes drastically shortened via canals between oceans and seas, many additional artificial waterways planned.

In addition to serving purposes like irrigation and trade, canals affect the world humans live in. Cities that flourished thanks to connected shipping routes were able to achieve further growth with sophisticated canal systems. Angkor Wat in Cambodia, historic Suzhou near the Chinese metropolis Shanghai, Venice, Amsterdam and Hamburg are just a few examples. Canals, however, are also exposed to the winds of change and the evolution of economies. Former widely ramified systems of old, narrow inland canals have fallen into a deep sleep. Supplanted by rail and hardtop roads, they at least still attract tourists in large numbers. By contrast, consistently extended, broadened and deepened canals as links to navigable rivers have retained their importance for domestic transportation. Even a lot more important, though, for the growing flow of goods in a globalized economy is ocean shipping. Canals – large enough to be navigated by huge sea vessels with thousands of containers – are the uncontested champions in terms of the number of passages and volumes of goods. Explore the following pages to find some amazing facts and stories from the world of artificial waterways.

ORIGINS IN EARLY ANTIQUITY

As early as in the 3rd century BC, the people of Mesopotamia knew how to take advantage of the Euphrates and Tigris rivers to build canals for irrigating their fields. Presumably, the first man-made navigable waterways were created much later. Egyptian pharaoh Necho II, in the 6th century BC, planned a connection between the Red Sea and the Mediterranean – practically a precursor to today's Suez Canal. The Canal of the Pharaohs was intended to connect a branch in the eastern Nile Delta with Lake Timsah and via another canal with the Red Sea. It was arguably completed only 350 years later, under Ptolemy II, but then already had locks at the junction with the Gulf of Suez.

*Dating back to the 6th century BC as well is the Hong-Gou Canal in China. It linked the Yellow River and the Huai River. Other canal projects followed in the subsequent centuries, particularly for the purpose of linking Beijing and the granaries in the fertile south. Since antiquity, **the near-1,800-kilometer (1,118-mile) artificial waterway** – still the longest one of all today – has extended from Beijing all the way to the estuary of the Yangtze with the metropolis of Hangzhou (pictured above). The southern part of this Grand Canal – a UNESCO World Heritage Site – is still used as a regional shipping route nowadays.*

A spectacular site:
the Corinth Canal
lined by rock walls

MONUMENTAL STRUCTURES

Artificial waterways have been built according to the same principle for thousands of years: Whereas thousands of workers using pickaxes and shovels used to excavate a channel that was subsequently flooded (pictured at center), excavators have been doing this job in recent decades – and making progress a lot faster. In addition, the base of the canal today is typically sealed to prevent the water from seeping away.

*Arguably, one of the narrowest canals for ships is a unique example of canal construction: **The six kilometers (3.7 miles) long and only 25 meters (82 feet) wide Corinth Canal** (pictured above) separates the Greek mainland from the Peloponnese peninsula. Between 1881 and 1893, it was not dug in the classic sense but rather carved out of the rock. The rock walls of this unique waterway extend up to 76 meters (249 feet) above the water level.*

*More than in terms of excavation work, engineering knowledge changed with regard to constructing locks and **lift locks to overcome the greatest possible differences in elevation with a canal**. So for instance, barges traveling the Main-Danube Canal are lifted in 16 locks for an elevation gain of 175 meters (574 feet). In the Belgian Canal du Centre, a vertical lift lock that was the highest up until 2002 lifts the ships by 73.15 meters (240 feet) (pictured right) still marking a world record for a canal. Only the lift lock at the Three Gorges Dam of the Yangtze River in China is higher: 113 meters (371 feet).*



Canal construction used to be a grueling and dangerous bone-grinding job. The construction of the Panama Canal alone is said to have cost 28,000 lives. The use of forced labor was not uncommon, as shown here in this picture of the White Sea-Baltic Canal construction project (1931–1933) in Russia



XXL-size lift: the
Strépy-Thieu
ship elevator
of the Belgian
Canal du Centre



The three most frequently traveled artificial waterways in the world: the Kiel Canal (pictured above, 32,000 ships per year), the Suez Canal (center, 17,000) and the Panama Canal (14,000)



CANALS INSTEAD OF CAPE CIRCLING

The canals of the greatest importance to the world economy with strategic significance no doubt include the Panama Canal in Panama and the Suez Canal in Egypt. Since 1914, the Panama Canal with a length of 82 kilometers (51 miles) has shortened a sea voyage from New York City to San Francisco by 15,000 kilometers (9,300 miles): Ever since then, ships have no longer had to navigate the dangerous waters at Cape Horn at the tip of South America. The nearly 170 kilometers (106 miles) long Suez Canal between the Red Sea and the Mediterranean has resulted in a travel distance shortened by more than 10,000 kilometers (6,200 miles) since 1969, obviating the need to navigate the long route from Asia to Europe around the Cape of Good Hope.

*Even at the time they were built, both canals were regarded as masterful achievements in waterways engineering. They are continually deepened and widened using **state-of-the-art construction technology in order to accommodate the growing number of container ship giants navigating the world's oceans.** More than 17,000 ships pass through the Suez Canal every year and since the most recent expansion in 2016 to the tune of eight billion dollars, about 14,000 ships loaded with up to 14,000 standard containers have been navigating the Panama Canal annually. However, the record of being the world's most frequently traveled canal with some 32,000 ship passages per year is held by the nearly 100 kilometers (62 miles) long Kiel Canal between Brunsbüttel on the Elbe River and Kiel in Germany that makes it possible for ships to avoid the route through the Scandinavian Skagerrak strait.*

INDUSTRIALIZATION CAUSES CANALS TO BOOM

In the interior of countries, entire networks of artificial waterways accelerated trade as well and boosted an economic upswing. For instance, in the early days of industrialization, a canal system with a length of 7,500 kilometers (4,660 miles) was created in the United Kingdom.

*In this era referred to as the period of “Canal Fever,” the costs incurred for shipping goods on barges instead of by horse-drawn carriages were cut by more than half. In the course of the 19th century, rail transportation increasingly gained importance. **Many of the canals were not upgraded and, as a result, are now too small for commercial ships. Today, they’re primarily used for recreational boating and tourism purposes.***

However, around the globe there are still canals that provide important routes for inland shipping, particularly in interaction with rivers or, for instance in North America, lakes as well. In the European part of Russia, a river and canal system with a length of 6,500 kilometers (4,038 miles) (guaranteed draft of 3.6 m / 11.8 ft. for vessels with load carrying capacity of 5,000 metric / 5,511 short tons) links the Baltic Sea, the Barents Sea and the Arctic Ocean in the north and the Black Sea and the Caspian Sea in the south.



The Duisburg Inner Harbor depicted here is the largest of its kind in the world. It’s the hub for the Rhine and Ruhr rivers and several artificial waterways

MEGA PROJECTS GOING FORWARD

*Planning of the **Nicaragua Canal** (map at left) under China’s leadership has been in progress for more than ten years. The struggle to make this project reality has been going on for at least as long. The link between the Caribbean and the Pacific as an alternative to the Panama Canal – construction costs are estimated to amount to 50 billion dollars – is intended to accommodate even the largest container ships across a distance of 287 kilometers (178 miles) with a water depth of nearly 30 meters (98 feet). However, numerous protests due to environmental concerns, the risks to Nicaragua’s drinking water supply and the displacement of the indigenous population have produced some effects. Whether the canal – particularly after the enlargement of the Panama Canal – will ever be built is anyone’s guess.*

*The situation won’t be a lot easier for a number of other ambitious canal projects either. **The Kra Canal, for instance, is planned to be dug through the south of Thailand in the next decade.** The waterway is intended to ease the burden on the heavily frequented Strait of Malacca between Malaysia and Indonesia. Again, China is regarded as the driver of the project being planned as part of the “Maritime Silk Road” initiative. **Slightly more probable is the construction of Canal Istanbul (map at right)** that, alongside the Bosphorus, is intended to link the Mediterranean (Sea of Marmara) and the Black Sea. Even before the ground has been broken, the Turkish government officially expects the project – estimated to cost 14 billion euros – to be completed in 2023.*



Relief or competition? In Nicaragua, a second Central American cross cut is planned

The huge gates of the new Panama Canal locks are up to 33 meters (108 feet) tall and up to ten meters (33 feet) thick. Extreme heavy-duty Schaeffler bearings help move these giants

BEARINGS FOR THE WORLD'S COSTLIEST SHORTCUT

*The size of the cargo ships navigating the world's oceans has been steadily increasing over the past decades – so it was logical that the Panama Canal had to grow at some point in time as well. In mid-2016, following a nine-year construction period, the new, third lane of traffic was opened on the waterway that – in terms of the volume of goods shipped – is the second most important one in the world after the Suez Canal. Whereas before only ships with a length of 294 meters (965 feet) and a width of 32 meters (105 feet) were able to navigate the passage, now freighters with a length of up to 366 meters (1,201 feet) and a width of 50 meters (164 feet) fit through the canal. Some 40,000 workers moved 110 million cubic meters (388,461,334 cubic feet) of earth for this purpose – 42 times the content of the Great Pyramid of Giza. Estimated costs: 5.25 billion U.S. dollars; **included in the price: more than 3,400 rolling bearings from Schaeffler.** The pendulum rolling bearings in the drums of humongous steel cable winches for instance ensure the motion of the lock gates. Due to the high torques, transmissions are additionally required here which in turn are equipped with Schaeffler's bearing solutions: in this case consisting of tapered and cylinder rolling bearings besides the pendulum types. To prevent wear, a large number of these bearings have been coated with Schaeffler's Triondur C – this technology enables **bearing life of 35 years**, with only five-year maintenance intervals: that's good for global trade requiring 24/7 operation.*

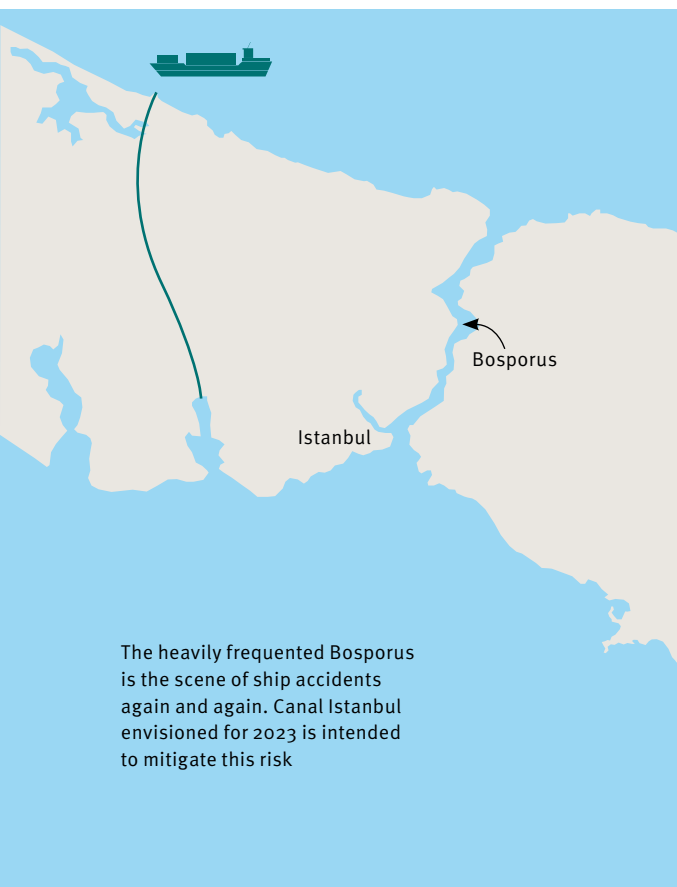

The heavily frequented Bosphorus is the scene of ship accidents again and again. Canal Istanbul envisioned for 2023 is intended to mitigate this risk



THE AUTHOR

As a sailor, author **Jan Oliver Löffken** loves open water. However, his research revealed to him the diversity of canals. Now he no longer views them only as fast trade routes but has also come to recognize their appeal for livable cities and exciting excursions.



BBALLI BBALLI!*

*(quick, quick!)

No other industrialized country has evolved from a developing into a highly industrialized nation at the breathtaking pace that Korea has seen. Unsurprisingly, as everything in the Land of the Morning Calm revolves around speed. Martin Hyun, an author of books and son of two South Koreans living in Germany, provides “tomorrow” with insights into a culture of acceleration.

— by Martin Hyun

— When in 2015 I temporarily moved to Korea to assume my role as technical sports director of the ice hockey games of the Winter Olympics and Paralympics in Pyeongchang I personally experienced once again what it means to live in a “bballi bballi” (“quick, quick”) driven culture. Here’s a case in point: In Germany, it took me nearly two months to get my internet connection at the time and I had to wait at home for the technician to arrive sometime between 8 a.m. and 4 p.m. This would be totally unthinkable in service-oriented Korea. From the time I ordered my internet connection in Korea until it was installed a possibly record-breaking two hours elapsed. The technician arrived on time at 1 p.m. as

agreed and accomplished the job in just a few minutes. Life in Korea is typically hectic and fast-paced, especially in the metropolitan area of the capital city, Seoul, that’s home to half of the country’s population.

Particularly in big cities, people will often bump into you. But that shouldn’t be regarded as rude behavior. It’s simply part of life. Although Koreans are generally very polite, reserved citizens you shouldn’t expect any apologies after such involuntary body contact. Impatience beats etiquette. It’s not for no reason that Koreans, especially those in Seoul, are regarded as the Italians of Asia – including their occasional display of

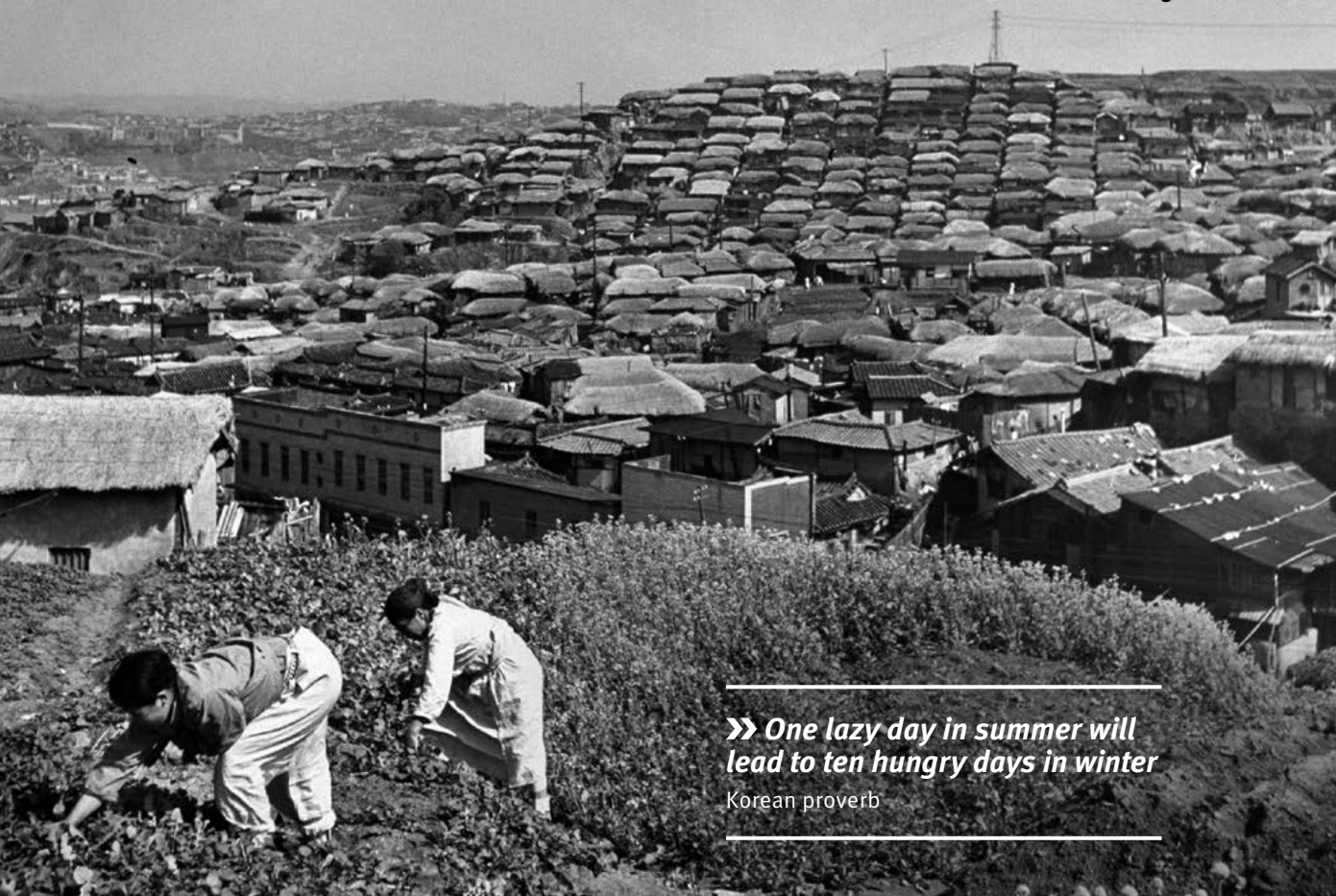

» *One lazy day in summer will lead to ten hungry days in winter*

Korean proverb

temper. So, unsurprisingly, even the parliament has seen flying fists among its members.

A developing country in the past, a world leader today

The so-called Tiger State, Korea, has the world's fastest internet. The average internet speed of about 29 Mbps/second is about twice as high as Germany's. During the 2018 Olympics the world's first 5G mobile network that's planned to be implemented across the country in 2019 was tested. It's 100 times faster than previous LTE networks. Be it in the deepest subway tunnel or on the highest mountain: Korea has near-total network coverage of 96 percent. WLAN hotspots are accessible practically anywhere as well – a condition that people in Germany can only dream of. However, that hasn't always been the case. In the 1960s, Korea was still a developing country. The wounds inflicted by the civil war with the communist North (1950–53) were slowly starting to heal. At that time, there was one phone connection per about 300 inhabitants. Just a few decades later, Korea holds one of the top spots in the world ranking in the areas of telephony, smartphone and internet penetration.

In view of the country's tremendous enthusiasm for technology, it's hardly surprising that Songdo, the world's first Smart City, was created here and that Google established its first "Campus," a habitat for startups, on the Asian continent, in Seoul. However, as nearly always in life, there's a downside too: In the wake of the success of high-speed internet and smartphones, rampant smartphone addiction has become a serious social issue.

From 0 to 100 with steel, cars and electronics

When I started my job in Korea in 2015 the foundations for the ice rinks were in the process of being laid. International experts had doubts about the rinks being finished in time for the Olympics. I put the experts at ease and explained to them: "If there's a country that can do it, it's Korea." And that's exactly what happened and better yet: All the rinks were finished even a year before the Games. The luxury hotels for high-ranking officials in Gangneung virtually mushroomed as well: bballi prevailing on construction sites too. The "Lotte World Tower" in Seoul's Jamsil-dong district grew to an impressive height of 555 meters (1,821 feet) in the space



Position 1

is held by South Korea in the “**2018 Bloomberg Innovation Index**” ahead of Sweden and Singapore.

5 production sites at three locations are operated by **Schaeffler** in Korea. They produce products for a large number of customers in the core segments of the local economy, including automotive, general industrials, electronics, semiconductors and aviation.

212 billion

dollars in sales were generated by **Samsung Electronics** in 2017. The tech giant established in 1969 is the world leader in the TV, cell phone, smartphone, memory, semiconductor, SIM card, refrigerator and digital signature markets.

In 1999

– 5 years before Facebook – “**Cyworld**,” the first social network, went online in South Korea.

4 of the world’s largest shipyards are located in South Korea.

In 1955

the first automobiles were built in Korea under the name of Sibel. The body of the Jeep imitation was put together from old oil barrels. The **fifth-largest automaker in the world**, by its own account, is Hyundai-Kia Motors: another example of Korea’s rapid rise.

of just five years, making the skyscraper the fifth-tallest building in the world. The adjacent “Lotte World” is even the world’s largest theme park – to mention just one more example of superlative dimensions. Both are located in an area that as recently as in 1970 was home to merely 300 households. In spite of the construction boom, residential space is in scarce supply in Seoul; the cost of housing is among the highest in the world. Quite a few residents have to take on a second job in order to be able to afford the horrendously high rents.

The Miracle on the Han River

Now, how was it possible to achieve this rapid rise from a developing country to the eleventh-biggest economic power in such a short period of time? The “Land of the Morning Calm” for a long time used to be a pawn in the hands of the powers, Japan, China, the United States and Russia. In the 1960s, the annual per capita income of Koreans was an equivalent of 87 dollars. Today, it’s 27,500 dollars. If you ask Koreans who’s responsible for the “Miracle on the Han River” they’ll typically answer: Park Chung-hee.

The former Korean president, who took power by a military coup in 1961, launched his first five-year plan in 1962. It was mainly focused on developing the country’s infrastructure, agricultural production and the promotion of light industry and further technological development. Other key areas were education and energy supply. This plan was followed by five-year plans two (1967–71, focused on promoting heavy industry), three (1972–76, focused on promoting the chemical industry), four (1977–81, continued promotion of the chemical and heavy industry, but economic setback due to political turmoil and the oil crisis, end of the military dictatorship), five (1982–86, transformation departing from the heavy and chemical industries toward technology-intensive sectors like electronics and precision-engineered machines) and six (1987–91, promotion of small- and medium-size enterprises and strategic industries such as the automotive, mechanical engineering and electronics sectors). In the process of their accelerated development, the Koreans did not shy away from adapting the success formulas of other countries – in order to subsequently improve them.

Left behind by the pace of modernization

It took Europe 300 years to put the system of modern capitalism on solid ground. South Korea accomplished this fundamental social transformation under two military dictatorships between 1960 and 1980, said Hwang Sok-yong, one of South Korea’s most famous writers, in 2014, in a documentary produced by the



Lights as prosperity indicators: Whereas South Korea rose to the level of a rich high-tech nation, the North remains in the poverty of the post-war years – and in darkness at nighttime

Frenchman Jacques Debs. According to Hwang, the process of modernization overran Korea within a very short period of time. In the view of the novelist, who doesn't shy away from controversy, in addition to the ability of carefully weighing and challenging decisions, social justice fell by the wayside as well. In fact, according to an OECD study, Korea, in spite of significant increases in recent years, is still spending less than 15 percent of its gross domestic product on social benefits and services. For comparison: France and Finland spending over 30 percent of their GDP are deemed front runners in this respect. Like in many industrial nations, the gap between rich and poor keeps widening in Korea too.

Another issue: In terms of old-age poverty, Korea ranks in one of the less-than-pleasant top spots among the leading industrial nations as well. This is also partly attributable to the fact that the rapid social transformation has made the model of large families in which the members support each other obsolete. Many retirees feel useless, fear that they won't be able to make ends meet and would rather end their life voluntarily than live in undignified conditions. Policies to counter this trend are urgently needed in the light of demographics reflecting fewer and fewer young people that will be able to support their elders. Korea's birthrate is one of the lowest in the world. One in two Korean women doesn't want to have any children at all – a choice also driven by the fear of being pushed into the role of homemaker and mother. In terms of emancipation, Korea's male-dominated society has some catching up to do as well.

The hungry spirit of the Koreans

The country's technological upswing initiated and planned by Park Chung-hee was massively accelerated by another factor: the Koreans' "hungry spirit" – as my uncle, a successful civil engineer from Seoul, likes to call it. This unbridled and unbending will to "make a believer out of the world" has a major part in Korea's evolution from a developing country into one of the leading

industrial nations. There's nothing that goes against the ambitious Koreans' grain more than taking the easy way out, novelist Hwang Sok-yong writes as well. 60-hour work weeks are the rule rather than the exception. Peter Schreyer, the German designer who has been drawing sleek-looking body shells for Hyundai and Kia since 2006, in a television documentary was obviously impressed as well by the eagerness of the Koreans who, he said, were not only driven by personal ambition but also by pride in their country.

The Koreans' hungry spirit is also manifest in education. The competition for acceptance by a "SKY" university is massive. SKY stands for the three top Korean universities, Seoul National, Korea and Yonsei. High school students spend up to 16 hours a day cramming for good grades in order to be accepted by one of the top universities. If the young academic manages to graduate with honors access to the coveted social elites is practically guaranteed. Parents are willing to spend a major portion of their income on the education of their children. However, the educational frenzy paired with a fear of failure has a downside as well: Korea is one of the countries with the highest teenage suicide rates.

Even so, more and more foreign students are flocking to South Korea. Seoul already ranks in the top ten of the most popular student cities listed on the website of topuniversities.com. Like the country as a whole, the number of universities has been seeing massive growth. While Korea still had 70 colleges and universities in 1965 (14 public and 56 private ones) the number had more than tripled 50 years later (46 public and 179 private ones). The educational turbo has produced a country-wide academization level of 70 percent. As a result, many graduates are no longer able to find adequate jobs at home and start looking abroad, so it's definitely within the realm of possibilities that a young couple will follow my parents' example and seek their fortune in Germany ...



THE AUTHOR

Martin Hyun was born in 1979, in Krefeld, Germany, and since 1993 has been a "happy German citizen." Hyun studied political science and international relations in the United States and Belgium. He made headlines as the first ice hockey Bundesliga pro of Korean descent and as a player in Germany's National Junior Division. His first book was published in 2008. In his bestseller, "Gebrauchsanweisung für Südkorea" ("User Manual for South Korea"), he reveals for instance why you have to stand your ground in the "Korean triathlon" – eating, drinking, singing.

ADRENALINE RUSH

Nearly all of us know it and some of us need it – the thrill of speed. But why do we find pleasure in fast-paced motion?

— by *Wiebke Brauer*

— They say that nothing's as sweet as the moment when pain subsides. That's true to some extent for the thrill of speed as well. This unique feeling fueled by the awesome power that pushes us into a seat, the promise of turbulence, freedom and adventure, the roar of the engine and the beating of the

heart – and by the sense of sheer relief about having escaped the danger zone. We did it – we pushed the limits – and just by sitting still and using one foot. Now if that's not a case of mind over matter then what is?

Mockingly, one might respond that it's a normal chemical

reaction paired with irrational behavior. Worse yet, it's probably all the mammoths' fault. For our ancestors, hunting was as hazardous as it was necessary for survival and a successful outcome was not only rewarded with a full belly but with a euphoric high – and the combination of both resulted in a momentous



ON WATER

Bjørn Dunkerbeck, a surfing legend and with 42 world championship titles under his belt one of the world's most successful professional athletes: "I'm a real speed fan, even organize my own event, the Dunkerbeck Speed Challenge. In spite of a decent surf, we achieve speeds of up to 80 km/h on our boards – that feels like 250 in a car, except that you've got nothing surrounding you. Only the speed event in Lüderitz in Namibia is more extreme. On a dedicated canal, we try to smash the 100-km/h mark every year. My current record is at 98.80 km/h – and that's already like flying."

link: 100,000 years later, modern humans voluntarily climb into roller coasters, fill their garages with over-powered sports cars and drive faster than the legal speed limit allows. Today, entire industries thrive on the fact that we fly, race, jump from great heights or have ourselves catapulted into the air just for fun.

“Speed” cells in the brain

Obviously, the idea of using speed to make money is not a new one. Just a few weeks after the first German train line between Nuremberg and Fürth was opened on December 7, 1835, high-speed trips

at 70 kilometers per hour were offered – to the great delight of the audience. By the way, the warning issued by a Bavarian medical committee at the time that train trips at speeds above 30 kilometers per hour would cause travelers and spectators alike to suffer severe brain damage such as “delirium furiosum” is a fallacy, whereas speed being measured with the help of so-called speed cells in the brain is not: In October 2014, spouses May-Britt and Edvard Moser from Trondheim University were awarded the Nobel Prize in Medicine for their discovery of cells that constitute a positioning system in the brain and are part of a system in the hippocampus, a kind



It's fun to put the pedal to the metal: a rising adrenaline level stimulates areas of the brain so that fast driving is perceived as a reward



ON THE SLOPE

Lindsey Vonn, U.S. ski racer, Olympic gold medalist and world champion in an interview with “USA Today”:

“I love going fast. It’s all I ever wanted to do. Going fast is fun. Every time I get to do a downhill or I’m going fast, I get to the bottom and I’m smiling. I’m grinning ear to ear because it’s just so invigorating. You feel so alive and so fresh and so free.”



of cerebral control center. The speed cells sense acceleration 100 milliseconds in advance. Nothing is faster than the human brain.

Euphoria and “angstlust”

Albeit, this does not explain why laying some rubber on the road is so exhilarating. Aside from the visual and acoustic sensations, it’s a hormone cocktail that definitely compares with an experience of drug frenzy. However, heroin for instance attaches to the receptors on the nerve cells of the cerebral reward system, directly resulting in a feeling of euphoria. In the thrill of speed, though, the rising adrenaline level stimulates areas of the brain so that fast driving is perceived as a reward because additionally the neurotransmitter dopamine and reward molecules such as opioids and endocannabinoids are released. The result is a biochemical double dose of stress and relief – the ultimate kick-down in the brain.

Plus, there’s the human mind that drives us more vehemently than any hormone does. In the late 1950s, the Hungarian psychoanalyst Michael Balint coined the German term “angstlust” (roughly meaning “zest for fear” in English). It describes the thrill, the enjoyment of risk and danger – and thus of maximum speed as well. Balint explained this questionable pleasure primarily as abandoning and recovering safety. In principle, this interaction corresponds to the biochemical reaction. Both physically and psychologically, we can say: it’s great that it’s over.

Seeking sensation? Not everyone’s cup of tea

Why some people, however, basically have no interest in seeking thrills was explained by American psychologist Marvin Zuckerman in the 1960s. He described behaviors



IN FORMULA ONE

Mario Andretti, U.S. Formula One Champion and Indy500 winner:
“If everything seems under control you’re not going fast enough.”

IN HIGH-SPEED TURNS



Mike Rockenfeller, DTM Champion, Le Mans winner and Schaeffler brand ambassador: “Freeways, roller coasters, road bikes or jet skis – they all can be fun. But I only feel a true speed thrill on the race track in extremely fast turns. When the centrifugal forces claw you, when the track feels like it’s getting narrower and narrower – that’s when you feel the speed and say to yourself: Wow, that’s really fast now. There are three corners that give me a particular high: at 280 km/h in an LMP1 sports car through Eau Rouge at Spa, the Porsche corners at Le Mans, especially when flying through them at night at far more than 200 km/h and the Schwedenkreuz on the Nürburgring Nordschleife. This corner has become so incredibly fast. Really awesome. You think that’s actually impossible. You reach a hilltop at just under 280 km/h, briefly lift and speed down the fast left-hander at 260 km/h. That’s a sheer thrill of speed.”

IN FORMULA E

Lucas di Grassi, Formula E Champion: “I’ve raced at Le Mans at 350 km/h – but whenever I sit in a race car I’m so focused that I don’t even notice the speed. After all, every move and reaction on a Formula E street circuit at 120 km/h has to be just as precise as on a ride beyond the 300 mark. When I ride my electric foil on water and the water splashes upward that sometimes seems faster to me than racing on a long straight.”

Daniel Abt, Formula E driver: “I just recently experienced the pure thrill of speed during a free-fall parachute jump: nearly 300 km/h which – even though for just a few seconds – I directly felt on my body. That’s when all my brain functions were shut off for a moment. In my Formula E car, it’s not the speed but the incredible acceleration that keeps knocking my socks off even after a few years.”



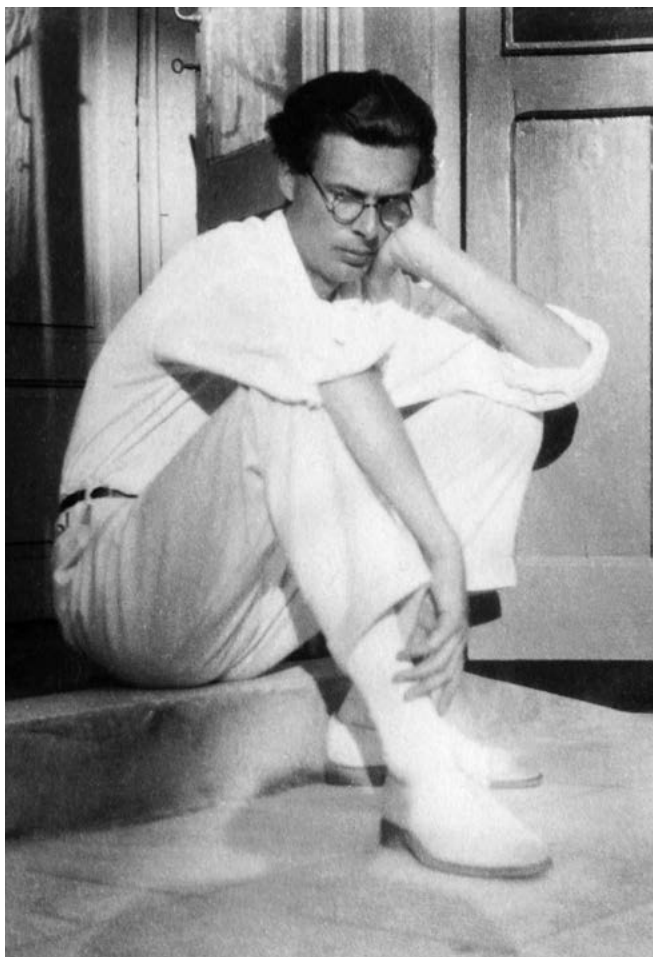

IN LITERATURE

Aldous Huxley (1894–1963) in his “Moksha Writings on Psychedelics and the Visionary Experience” (Stonehill Publishing Company): *“When the car has passed seventy-two, or thereabouts, one begins to feel an unprecedented sensation – a sensation which no man in the days of horses ever felt. It grows intenser with every increase of velocity. I myself have never travelled at much more than eighty miles an hour in a car; but those who have drunk a stronger brewage of this strange intoxicant tell me that new marvels await anyone who has the opportunity of passing the hundred mark. At what point the pleasure turns into pain, I do not know. Long before the fantastic Daytona figures are reached, at any rate. Two hundred miles an hour must be absolute torture. But in this, of course, speed is like all other pleasures; indulged into to excess, they become their opposites.”*

he allocated to the personality trait of “sensation seeking.” The fear signals emitted by the body are interpreted according to a person’s character. In some people, hair-raising experiences evoke feelings of sheer horror and in others of sheer ecstasy: a typically male reaction? Accident statistics at least support this notion. 73 percent of all worldwide traffic fatalities are men. Admittedly, they drive twice as much on average as women. In terms of exceeding speed limits, though, both genders are on a par, as the surgeon and accident researcher Julia Seifert said in an interview with “Mitteldeutsche Zeitung”: “When men approach a corner where the speed limit is 80 km/h they’ll just say to themselves: I’ll take it at 120. For them, it’s more about adventure and thrill. Women (...) tend to say: 90 should work as well. Both, though, are driving too fast.”

Mockers in turn might agree with the Austrian psychiatrist Erwin Ringel who wrote that driving cars was sometimes misused as a way of escaping from oneself. And that, at times, cannot be fast enough. —



THE AUTHOR

Journalist **Wiebke Brauer** feels that acceleration is one of the last joys of motoring, especially since she gets caught in a traffic jam after a short distance of traveling in her native Hamburg anyway. High speed per se does not hold a particular appeal for her – which might also be due to the fact that her cars are very old.

HEROES

WITH SUPERSPEED

Superheroes and their superpowers: When it comes to acceleration, Superman, Flash & company push the boundaries of human imagination. “tomorrow” shows what high-speed rides and other top performances these heroes are capable of. Limits? Forget it!

— by Björn Carstens

SUPERMAN



WHO AM I?

IN 1938, I CRASH-LANDED ON EARTH FROM THE FICTITIOUS PLANET KRYPTON. AS SUPERMAN I BECAME THE FIRST SUPERHERO HERE IN THE HISTORY OF COMICS AND FATHER OF AN ENTIRE GENRE. I DO FEEL A LITTLE EMBARRASSED ABOUT ALL THIS FUSS ABOUT BEING A SUPERHERO, SO I GOT MYSELF AN ALTER EGO: THE BESPECTACLED REPORTER CLARK KENT. ONE THING I NOTICED IN ALL THESE YEARS ON EARTH: I APPEAL TO WOMEN MORE THAN TO MEN. SEEMS LIKE I'M TOO PERFECT FOR THEM, OR MAYBE THEY'RE JUST ENVIOUS ...

Acceleration factor Classified as "faster than a speeding bullet" (around 1,600 km/h / 1,000 m/h) by his creators, Jerry Siegel and Joe Shuster, Superman's pace keeps picking up over the years. In the first Superman movie from 1978, the iron hero flew around the Earth to turn back time. The speed he needed in order to do that: 1 billion km/h (621 million m/h), according to calculations by physics students in England. Now would it be safe to assume that the makers of the movie took that into account?

Other fortes Actually, anything from X-ray, microscopic and heat vision to extreme lung volume, super hearing and photographic memory to super-human strength and by-and-large invulnerability.

Weaknesses The mineral kryptonite from his home planet, his girlfriend Lois Lane.

FLASH

Acceleration factor Flash achieves the speed of light (300,000 km/h / 186,000 m/h), which makes him invisible. His races against Superman are legendary. While initially they end in ties, the decision is produced in "Adventures of Superman #463": a clear stamina-based victory for endurance runner Flash vs. sprinter Superman. An episode of the the "Smallville" series shows a similar scene: Flash nonchalantly turns around, waves at Clark and disappears on the horizon out of reach.

Other fortes Is able to travel through walls and through time.

Weaknesses Water slows him and on ice-covered surfaces he slips.



WHO AM I?
I'M BARRY ALLEN AND LIVE IN CENTRAL CITY WHERE I'M FIGHTING CRIME, INITIALLY AS A FORENSIC CHEMIST. HOWEVER, WHEN A LIGHTNING BOLT STRUCK ME DURING THE EXPLOSION OF A PARTICLE ACCELERATOR, I MUTATED INTO FLASH, THE FASTEST HUMAN ON EARTH.

WHO AM I?
EXILED BY ODIN, MY FATHER AND THE FATHER OF ALL GODS, I CAME TO EARTH. HERE I HAD TO LIVE FOR MANY YEARS WITHOUT A MEMORY AS THE PARTIALLY DISABLED PHYSICIAN DR. DON BLAKE - BUT THEN I FOUND MY MYSTICAL HAMMER, "MJOLNIR," AGAIN AND EVERYTHING CHANGED ...



Acceleration factor 1.98 meters (6.5 feet) tall and weighing 140 kg (309 lb), Thor is a hulk of a man but fast only when he thrusts his mystical hammer, "Mjolnir," forward to propel him. In that case, though, it's enough for speed of light.

Other fortes Nearly invulnerable, quick self-healing powers, retarded aging process, multi-lingual and highly intelligent.

Weaknesses As a warrior tends to have a violent temper.

THOR

IRON MAN

WHO AM I?
MY NAME IS STARK, TONY STARK.
MY COMPANY, "STARK INDUSTRIES," THAT
I DEVELOP WEAPON SYSTEMS WITH HAS MADE
ME A MULTI BILLIONAIRE. A DANGEROUS INDUSTRY,
AS I HAD TO PERSONALLY FIND OUT WHEN I WAS
TAKEN PRISONER IN VIETNAM. IN ORDER TO BE ABLE
TO ESCAPE FROM THERE I DEVELOPED MY FIRST
MULTI-FUNCTIONAL GEAR THAT I CONTINUED
TO EXPERIMENT WITH. BY NOW I'VE
PERFECTED IT.



Acceleration factor Unlike other superheroes, Iron Man does not fly with the force of his body but with propulsive force. In his case, the top speed information provided varies as well. Surely, though, he travels faster than Mach 2 because he's able to follow fighter jets.

Other fortes Iron Man has no superpowers of his own. Instead, his abilities strictly depend on his exoskeleton. With it he's able to fire energy rays and to generate a force field around himself.

Weaknesses Needs an external, magnetic energy source in his chest to prevent being killed by shrapnel in his body.

SPIDER-MAN



Acceleration factor Even on foot, Spider-Man is clearly faster than a car. He moves around so quickly that the human eye can only catch a blurred view of him. In one comic book, he rushes to a bank robbery – covering two miles in five seconds. That equates to 2,317 km/h (1,440 m/h). And he does so not swinging from a strand of spider silk but, oddly, by leaping like a frog.

Other fortes Superhuman stamina, agile, strong and smart as well. With an IQ of more than 180 any intelligence test is child's play for Peter Parker.

Weaknesses In his personal life, Peter is regarded as an unlucky sort – like the Donald Duck of superheroes in a way.

WHO AM I?
MY NAME IS PETER PARKER. WHEN I WAS BITTEN BY A RADIOACTIVE SPIDER MUTATED ENZYMES ENTERED MY BLOODSTREAM. THAT GAVE ME SUPERHUMAN POWERS WHICH I USE TO FIGHT INJUSTICE - IN KEEPING WITH THE MAXIM: WITH GREAT POWER COMES GREAT RESPONSIBILITY.

SILVER
SURFER

WONDER WOMAN



WHO AM I?

IN 1941, WHILE WOMEN AROUND THE GLOBE WERE ONLY ABLE TO DREAM OF EQUAL RIGHTS, I WAS CREATED AS THE FIRST FEMALE SUPERHERO BY COMIC FAN WILLIAM MOULTON WHO WAS KNOWN AS A FEMINIST. MARSTON, WHAT A BRIGHT BRAIN, WAS CONVINCED OF THE MORAL SUPERIORITY OF WOMEN, SO I WAS BORN: THE AMAZON PRINCESS DIANA ALIAS WONDER WOMAN, AS STRONG AS SUPERMAN, BUT WITH AMPLE FEMININE CHARM AND - IF I MAY SAY SO - VERY SEXY.

Acceleration factor Superspeed is firmly anchored in the mythology of Wonder Woman. On one occasion, she's able to fend off bullets from a rifle that normally travel one kilometer per second. On another, she's even able to keep pace with Flash. For her fans, Wonder Woman is a "Speed Demon."

Other fortes Incredible reflexes and the ability to fly.

Weaknesses She loses her powers when a man binds her bracelets together or ties her up.

WHO AM I?

MY NAME IS NORRIN RADD. WHEN MY HOME PLANET, ZENN-LA, WAS ATTACKED BY THE PLANET DEVOURER GALACTUS I OFFERED MYSELF UP AS A HOSTAGE TO SAVE MY PLANET. EVER SINCE THEN, I'VE BEEN SURFING THROUGH SPACE TO FIND UNINHABITED PLANETS AS FOOD FOR GALACTUS.



Acceleration factor Equipped with cosmic powers, he steers his galactic surfboard through space at speeds faster than light and even traverses hyperspace.

Other fortes His silver-metallic skin is nearly impenetrable. Neither heat nor any type of hazardous radiation affect him. He can also heal living creatures.

Weaknesses Actually, only his unfulfilled love for Shalla Bal whom he was forced to leave behind on his home planet.



ACCELERATED DELIVERY

— Today, immediate access to news from around the world is no problem thanks to the worldwide web. Irrespective of the topic or region, a mouse click is all it takes to be comprehensively informed. 175 years ago, the situation was still completely different. When U.S. President William Henry Harrison dies in Washington in 1841 people living in far-away Los Angeles, believe it or not, learn about his passing 100 days later. Mail-coach service introduced in 1850 accelerates the transmission of news across the same distance to one month. Eleven years later, the pony express riders reduce the delivery period to two weeks. From 1869 on, trains further accelerate the pace, now achieving deliveries within four days. Within the space of just 28 years, this equates to a 2,500-percent time gain in the physical transmission of messages. Electronically, information was transmitted even faster: with the telegraph. Around 1870, large parts of the world are already wired although the

network does have gaps and particularly in rural regions distances between telegraph offices have to be bridged by human messengers in time-consuming ways. Even wireless telegraphy (from 1897 on) is unable to solve a particular problem: the final delivery of a message from the telegraph office to the recipient which – depending on the remoteness of the location – may still take hours or days. Only domestic phone connections – complementing radio (from 1919 on) and TV (from 1931 on) – enable direct exchange in real time. The practical conversational device spreads rapidly. In 1881, the first German phone book is published in Berlin – with 100 entries. In 1910, as many as 941,000 phone connections are already counted in Germany and 10 million worldwide. Today, telephony, television and the internet are largely fused with each other and accessible anywhere – per satellite connection even on Mount Everest.

in motion

Innovations in the course of time

»» *The horse doesn't eat cucumber salad*

The first sentence ever spoken via a telephone (Johann Philipp Reis, inventor of the Reis telephone, on October 26, 1861)

DATA TRANSMISSION SPEED

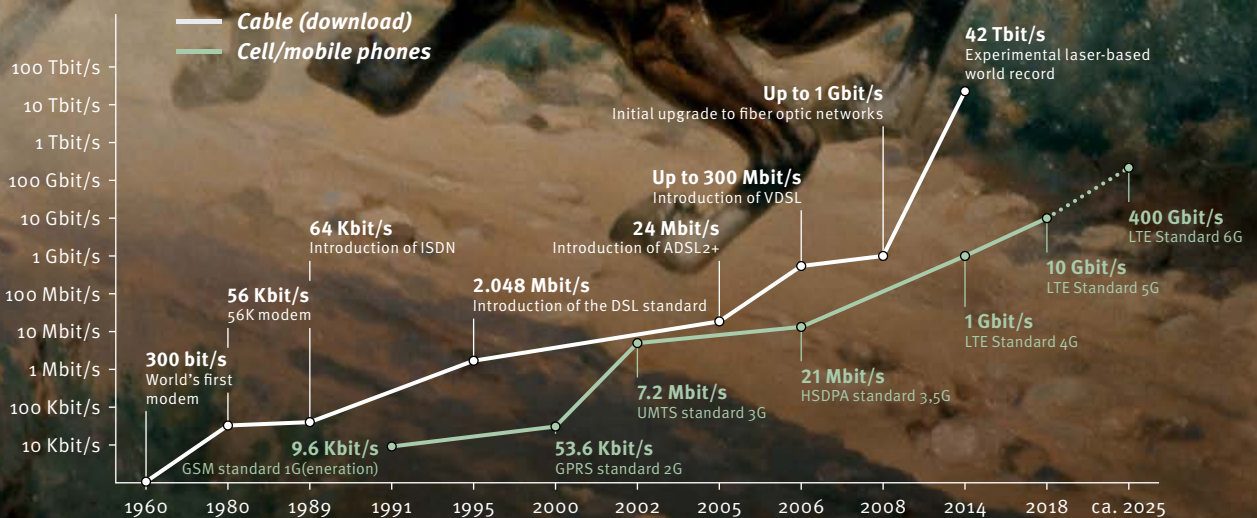

IMPECCABLY ROUND **AND SMOOTH**

No bearing would rotate without perfectly shaped steel spheres. The rolling elements exhibit variances only in the micrometer range: a manufacturing technology feat whose beginnings date back more than 130 years – and that today ensures proper rotation and smooth acceleration.

— *by Denis Dilba*

— Rolling minimizes rubbing. This, in a nutshell, describes the equally simple and ingenious basic principle of a ball bearing. Its standard design has consistently remained the same for more than two centuries: an outer ring, an inner ring and a cage that retains, with equal gaps between them, the balls that gave the bearing its name. That's basically it. And that's what even the first modern grooved ball bearing looked like for which the British inventor Philip Vaughan was awarded a patent in 1794. It was designed to support axles in carriages – and still an exotically new technology at the time. Today, ball bearings have long become standard components used billion-fold around the globe. Most of them are found in automobiles, aircraft, wind turbines and cranes. The smallest versions untiringly toil away in dental drills or computer hard discs. They even assist everyday items like vacuum cleaners, trolley cases, turntables or food processors in achieving the right rotary motion. Experts assume that today more than 100,000 different ball bearing designs and versions exist. In short, without these largely invisible everyday heroes the world would simply grind to a halt.

The ball grinding mill marks a breakthrough

At the core of the bearings are the balls – also referred to as rolling elements in technical jargon. They determine how smoothly a bearing runs. Although

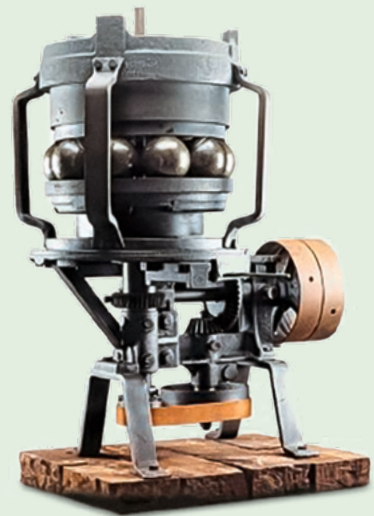

Boosted the development of rolling bearings in 1883: Friedrich Fischer's "ball grinding mill"



Ball blanks (l.) used to be cast. Today, thanks to advanced manufacturing technologies, they're pressed within fractions of a second from metal wire that was previously cut into small pieces (r.)

Vaughan's first ball bearing marked a technological leap from the previous plain bearings for axle applications the hand-crafted cast-iron balls used in his bearing were still a far cry from precision-manufactured products. They had to be painstakingly de-flashed by hand and then ground to assume a shape that was as round as possible. Also, compared to today's ball bearings, Vaughan's invention tended to rumble rather than truly running smoothly. That type of progress only came with the invention by a man named Friedrich Fischer. In 1883, after years of tinkering in his workshop, the locksmith and turner from Schweinfurt, Germany, managed to produce the first hardened cast-iron industrial-scale spheres that were exactly of the same size and perfectly round, using the "ball grinding mill" he had developed.

By employing a grinding technique previously utilized for grinding marbles, Fischer in his operation achieved accuracies of down to 20 micrometers (0.00079 inches) – a previously unknown level of precision. For comparison: The hair of a Central European has a thickness of 70 to 80 micrometers (0.0028 to 0.0031 inches). The ball grinding mill patented in 1890 resulted in the worldwide breakthrough for ball bearings – with Fischer's precision rolling elements they were running smoother than ever before because the closer the metal balls come to the ideal geometric form the lower the friction resistance they generate. The balls of ball bearings

SENSORS ON BOARD

For a long time, rolling bearings were a classic example of components that were inherently analogues. This changed with the introduction of so-called sensor bearings. Schaeffler's VarioSense bearing – a product that has won an award this year – provides several different measurements for machine and process monitoring – and as a connecting link between mechanical and electronic systems enables Industry 4.0 (aka industrial IoT or smart factory) solutions. Readings obtained in this way of rotational speed, temperature or force load make remote monitoring of component assemblies possible. As a result, impending defects can be detected due to noticeable changes in the signal curves before they lead to costly downtimes of an entire machine. In addition, continuous digital monitoring can reduce previously required maintenance intervals. At the moment, the VarioSense bearing launched last year is only available as a grooved ball bearing – however, VarioSense cylinder rolling bearings and tapered rolling bearings are currently in development.

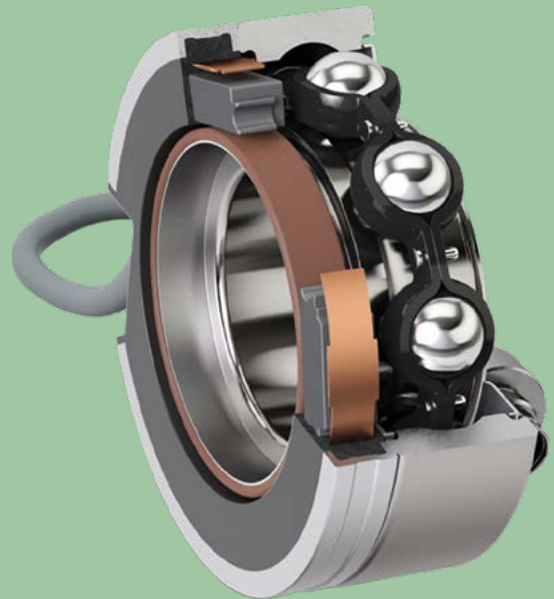

Measures, detects and warns: an FAG VarioSense bearing with a modular sensor concept

21.26 meters (69.75 feet)

*This is the distance across which the roundest of all Schaeffler spheres rolled. **The high-tech product with a weight of exactly 500 grams (17.64 ounces) and a diameter of five centimeters (1.97 inches) set this record** during a Japanese television show billed as “handwork vs. high tech.” In keeping with the show’s name, the Schaeffler team, led by Thomas Kreis, Vice President Competence Center Bearings, and Andreas Bohr, Vice President Development Ball Bearing, competed against a glass sphere crafted by an artisan factory in Yokohama. Although the Triondur-C-coated Schaeffler ball with a roundness of 160 nanometers (6.2992e-6 inches) was defeated by the glass ball from Japan, which achieved 30 meters (98 feet), it set a new record: **„A steel ball never rolled this far in previous shows“**, says Kreis: “A resounding success. Schaeffler received a lot of attention in Japan,” says Shinzo Yotsumuto, Managing Director of Schaeffler Japan, who is not at all upset about the “defeat.” It was to be expected: the form of the path and its lower weight gave the glass ball an advantage.*



The Triondur-C-coated Schaeffler ball with a roundness of 160 nanometers (6.2992e-6 inches)



Schaeffler experts explain the fortes and technical details of their high-precision bearing ball to a Japanese television crew



After the ball blanks have been rolled, hardened, pre-sorted, pre- and fine-ground, they move on to the washing stage (pictured) and ultimately final inspection

produced by Schaeffler today even achieve accuracies in the single-digit micrometer range. For the human eye, such minimal differences in the surface quality of the spheres that gleam like silver are not discernible – not only due to the perfection of their surfaces but also because ball production takes place at such a rapid pace: today, rattling machines spew out massive amounts of metal balls at one-second intervals.

Seven steps to success

Some 30 metric tons (33 short tons) of them per day leave Schaeffler's plant in Homburg, Germany. "We're basically able to provide every human being on Earth with one rolling element," says Matthias Feld, operations manager at the Homburg plant where ball diameters between 3 and 17.5 millimeters (0.1 and 0.7 inches) are

produced. In the Bavarian town of Eltmann, precision ball manufacturer Umbra produces up to eleven metric tons (12 short tons) for Schaeffler— all with diameters between 18 and 200 millimeters (0.7 and 7.9 inches). The latter are used in large-scale transmissions such as those of wind turbines, among other things. In contrast to the days of ball-production pioneer Fischer, the use of cast iron technology has long ceased in manufacturing the ubiquitous rolling elements. Today, the bearing component, whether small or large, that is the most challenging one in terms of manufacturing technology is always produced in a seven-step process: wire cutting, cold heading, de-flashing, hardening, grinding, pre- and post-lapping.

The perfect rolling element starts out as a steel wire. Wound on large rolls, the wire is placed on top of a ball press, fed into the machine and cut off. Subsequently, two semi-spherical dies, pressing against each other

Day after day, more than 40 metric tons (44 short tons) of steel balls are produced for Schaeffler in Germany alone. The picture shows the blanks joined together from two semi-spheres under high pressure at the beginning of the production process with the typical "Saturn ring"



WHERE STEEL BALLS REACH THEIR LIMITS

Steel balls in bearings for electric motors are prone to wear comparatively fast. “The currents generated there can flow from the outer ring of the bearing via the metal ball to the inner ring, and over time may damage the ball surface,” explains Schaeffler product manager Markus Seis. Therefore, ceramic balls are used for such applications as well. They’re produced from ceramic powder that’s compressed into shape and fused in a smelting furnace. The material has insulating properties, so damage by electric current is excluded. “In addition, ceramic balls,



Extremely tough but not exactly cheap: Cronitect hybrid rolling bearing

due to their higher hardness compared to steel spheres, have better emergency running properties,” says Seis. Even without a lubricating film they allow for a bearing to run slightly longer without suffering damage than steel balls. However, due to their more expensive production, ceramic balls cost about ten times more than their steel relatives, but offer longer maintenance intervals. Consequently, typical applications for ceramic balls are bearings in wind turbine generators where they help achieve savings in the costly deployment of cranes.



The balls Schaeffler assembles in rolling bearings have a size of up to 20 centimeters (7.9 inches)

with the force of about ten metric tons (11 short tons) give the wire sections the shape of a ball, resulting in a blank with a so-called Saturn ring and a pole. In the next step – de-flashing – these irregularities are removed and the ball becomes rounder. After that, the unfinished balls are hardened by heating them in a furnace and subsequently cooling them down again in oil. This arranges the atomic structure of the spheres in a way that makes them stronger. During grinding, pre- and post-lapping, the balls are machined using high-tech materials like ceramics or even diamond powder. For quality assurance, roundness and roughness are checked on randomly selected balls in special measuring rooms. This is followed by washing, a surface inspection – of every single ball – and finally by packaging. From Homburg or Eltmann the balls are then shipped to the customers’ sites where in diverse applications they invisibly and dependably do their job – and will keep the world in motion going forward.



THE AUTHOR

Author **Denis Dilba**, who has a master’s degree in engineering with a major in mechatronics and specializes in science and technology topics, has an ambivalent relationship with ball bearings:

while enrolled in his degree program the left-hander had to draw them countless times with pen and ink – causing his sleeves to suffer.



STOP!

Who in the world wound the clock? That's a legitimate question. Although, due to technological progress, we have more time than ever before it seems to be passing faster and faster.

— by *Wiebke Brauer*

— “Time is what you read on a clock.” The quote is attributed to Albert Einstein – and it would be great if things were that easy. Time always seems to fly and flee, to press and push, to slip through our fingers or to be consumed and stolen. Time can't be stopped, gained, saved or, let alone, be defeated. And although the likes of Shakespeare, Goethe, Marx or Proust were concerned even in their day about the rapid acceleration of life's pace the feeling of constantly being rushed and unable to do anything about it is a key characteristic of our modern accelerated society. Taking one step at a time? That, if at all, is a thing of the past.

Although we live longer, time's in short supply

Now it's not that people today have fewer hours at their disposal than they did in the days of Shakespeare. Quite the opposite is true! Aside from the fact that, as scientists found out, a day on Earth has become a millisecond longer in the past century, we also live longer and work less. The average life expectancy in Germany, for instance, has doubled in the past 130 years – and

about 100 years ago, people here used to work 57 hours per week on average. Today, it's 35.

Travel times have been shortened as well: “Since the days of the industrial revolution the world seems to have shrunk to about a sixtieth of its original size,” writes the sociologist Hartmut Rosa. While in the 18th century it took a whole month to get from London to New York, today an airliner will take us there in about eight hours. Trains, let alone automobiles, travel faster than they used to as well. On the other hand, cars in Berlin move at an average speed of about 24 kilometers (15 miles) per hour. That used to be the speed of stage coaches at the beginning of the 19th century, so maybe the best way to go is for us humans to get a move on. Apparently, that's exactly what we're doing because the walking pace of pedestrians in industrial countries has actually increased by ten percent within just a single decade.

Ultimately, almost all technological advances – be it elevators or digitization – served to save time and so would have had to provide us with more of it. But nothing could be further from the truth! Instead of enjoying the time we've gained at our leisure we're constantly

FASTER AND FASTER

SEVEN REAL-WORLD EXAMPLES

FASTER RUNNING

in seconds

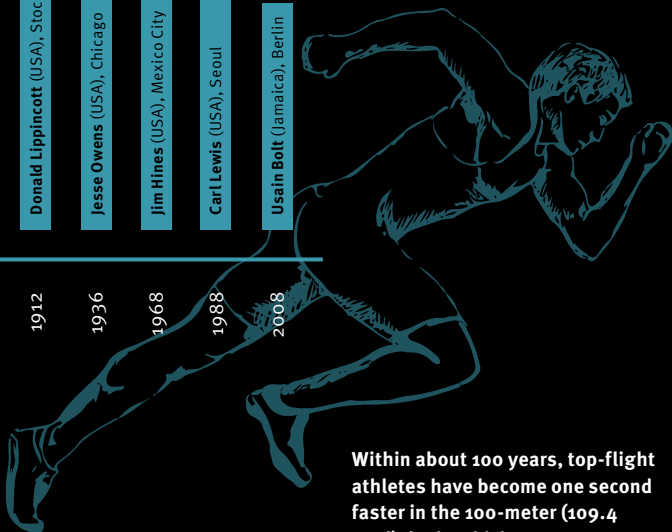
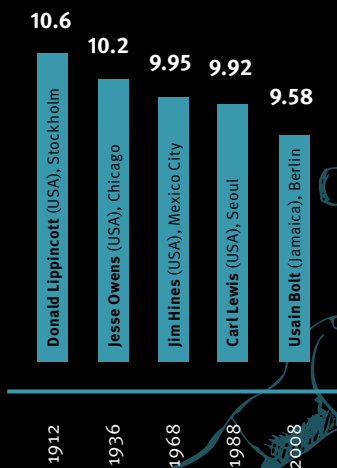

Within about 100 years, top-flight athletes have become one second faster in the 100-meter (109.4 yard) dash, which equates to an impressive 3.6 km/h (2.2 mph)

FASTER UP AND DOWN

in m/s

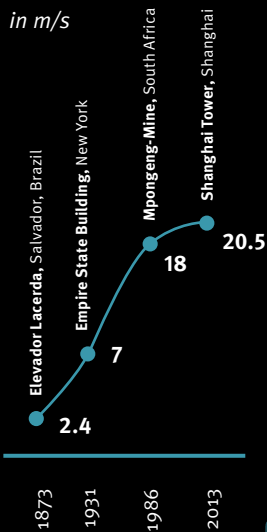

Within the space of 140 years, the speed of elevators has increased eight-fold

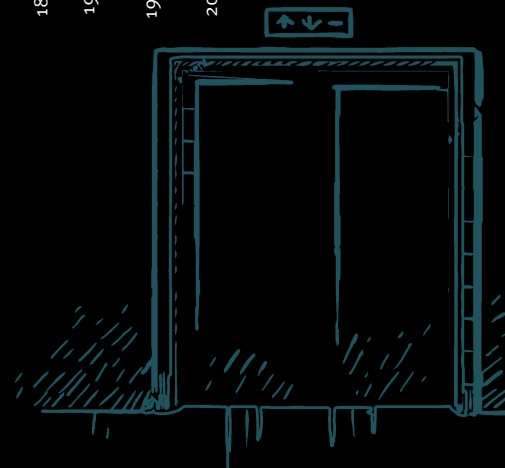

FASTER ACROSS THE ATLANTIC

The Blue Riband, officially introduced as late as in 1860, was originally awarded exclusively to steamships



Sirius, sidewheel steamship, Great Britain, 1838

Etruria, ocean liner, Great Britain, 1885

Bremen, 4-propeller high-speed steamer, Germany, 1929

SS United States, United States Lines, USA, 1952*

Cat Link V, catamaran, Denmark, 1998



* last steamer to have won the Blue Riband

under time pressure. For lunch we rush to the nearest fast food restaurant and wolf down a quick meal. We swipe potential matches on Tinder at one-second intervals, have friends on Speed Dial and grab a coffee-to-go to fight fatigue.

Frenetic standstill

The problem is that modern man and woman fail to recognize time as something that oozes away, as a scarce resource to be fully exploited while it's available and that it's best to avoid wasting it on meaningless things. However, our perception of time is a tricky thing. When we have fun the minutes seem to fly but when we're

dealing with adversity they seem to stop. Conversely, we have long and wide memories of things that made us happy – but only fleeting ones of those that didn't. This phenomenon is called "subjective time paradox" in which the time we experience and the time we remember are, in a manner of speaking, inversely proportional. And heaven knows what happens to time while we surf the worldwide web for hours on end or watch a series of television shows. Quite fittingly, the recently deceased French philosopher and theoretician of speed, Paul Virilio, coined the term "frenetic standstill" as long as a quarter of a century ago: a condition in which we stand by idly while the pace keeps accelerating and we feel as if the years are passing us by in fast forward mode. We sit or stand around, staring at phones, hastily tapping

FASTER SPRINTING FROM ZERO TO 100 KM/H

in seconds

Porsche in about fifty years from the original to the current model nearly cuts in half the acceleration time of the 911 from zero to 100 km/h (62 mph)

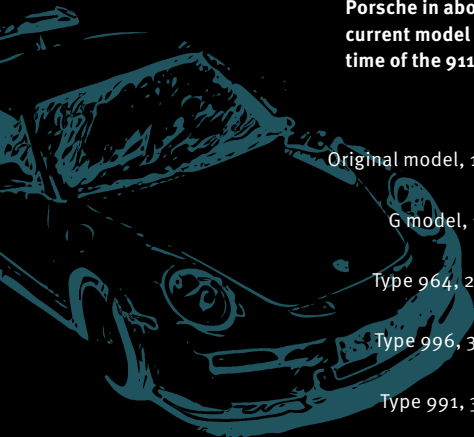

Original model, 130 hp, 210 km/h (130 mph) top speed, **1964**

G model, 165 hp, 215 km/h (134 mph) top speed, **1978**

Type 964, 250 hp, 260 km/h (162 mph) top speed, **1989**

Type 996, 300 hp, 280 km/h (174 mph) top speed, **1997**

Type 991, 350 hp, 287 km/h (178 mph) top speed, **2011**

9.0

7.8

5.7

5.2

4.6

FASTER COMPUTING

in OPS (Operations per Second)

1940
Zuse Z2, Germany

1942
Atanasoff-Berry Computer, USA

1946
UPenn ENIAC, USA

1976
Cray-1, USA

2018
Summit, USA

3

30

50,000

250,000,000

200,000,000,000,000,000

The first computers manage merely three operations per second, today's supercomputers 200,000 trillion



E-AXLE FROM SCHAEFFLER

FASTER DRIVING

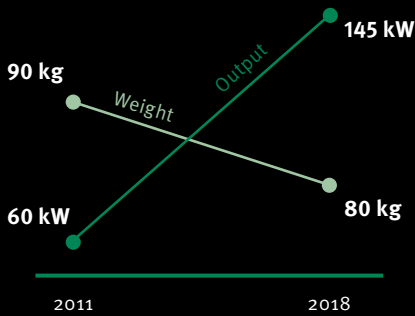

Higher output, lower weight: Today's E-axle from Schaeffler delivers 2.4 times the output of its predecessor from 2011 but weighs 11 percent less

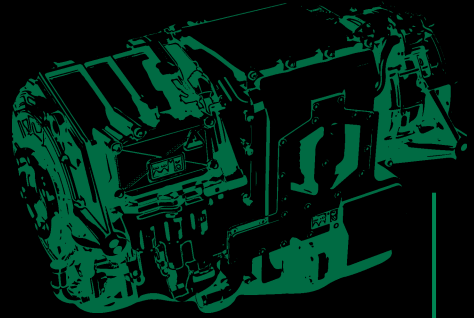

FASTER FLYING

in km/h (mph)



From 48 (30) to 958 km/h (595 mph) in less than 100 years – progress is evident in passenger aircraft as well

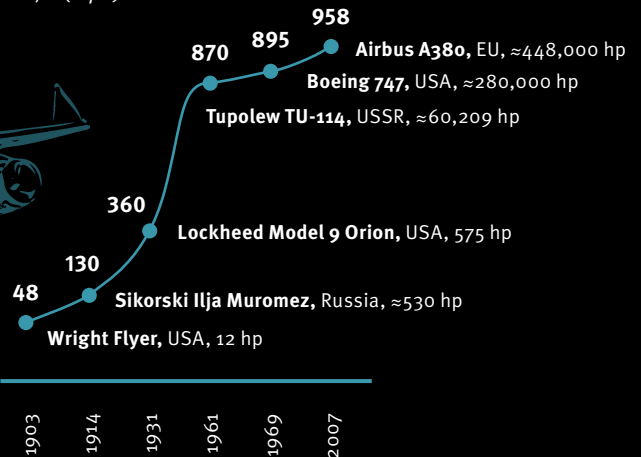

messages into keypads and watching breaking news and live video footage from around the world. Admittedly, all this can create a bit of confusion as far as the perception and organization of space and time goes.

Constantly up to speed

So, what are we doing about it? We step on the gas. “Acceleration becomes a substitute for eternity,” says Hartmut Rosa and what he means by this is that under time pressure – you’ve only got one life – we compulsively try to make use of every possible opportunity faster and faster while slowly but surely exhausting ourselves in the process. The official term for this is “fear of missing out” or its acronym “FOMO.” It refers to the modern-day concern of missing out on something crucial in life and of no longer being up to speed. Unsurprisingly, that’s the fault of modern technologies such as cell

phones and social networks – and relief is not in sight: for one because they incessantly generate new options and for the other because we’re hardly able to enjoy the present anymore. Instead of just sitting on a beach and counting the waves we take pictures and provide them as fodder for insatiable Instagram or Facebook feeds.

Now of course we could from time to time read a self-help book on how to decelerate or just throw our phones out the window. However, there’s another option that seems to make more sense to me: We could try to appreciate the hours again in which simply nothing happens, when boredom prevails and the moment appears to stretch into infinity. We shouldn’t make the mistake of dismissing boredom as a senseless waste of time. Even Goethe in his day thought highly of idle moments: “If monkeys managed to develop a feeling of boredom they might become humans.” On that note: allow yourself to be human all the way.

IF YOU BRAKE, YOU

“If you brake, you lose.” That’s what racers used to say, but now advanced technology – such as recuperation in electric mobility – allows them to gain a lot of ground through negative acceleration. However, the road to making this reality was a long one.

— *by Roland Löwisch*



WIN

— When in 1771 Nicolas Cugnot demonstrates his drivable behemoth named the “fardier” – a wooden, roughly four-ton steam-powered vehicle for transporting canons – his “automobile” hits a wall after just having traveled a short distance. If Cugnot hadn’t forgotten to install a brake, he’d have probably won – at least the spectators’ respect. However, the problem of decelerating wheeled vehicles is much older. It dates back to the days when horse-drawn carts kept getting bigger and bigger and a simple “whoa” was no longer enough to get draft animals to stop. Initially, wooden clubs are jammed against the ground or against the wheels and the first iron rim brakes only start appearing around 1690. And even though Baron Drais von Sauerbronn as early as in 1817 installs a controllable friction brake in his invention, the bicycle, and Bertha Benz during her famous 1888 drive of her husband’s “patent-motorwagen” has to have the

brake shoes re-lined with new leather in nearly every village on the way, the history of the truly effective brake only begins at the end of the 19th century.

In 1895, Hugo Mayer from Rudolstadt, Germany, is awarded a patent for the first “fluid brake,” but the world isn’t ready yet for such a hydraulically actuated and thus highly effective decelerator. Wilhelm Maybach in 1899 invents the original form of the drum brake onto which the brake shoes are pushed from the inside against a drum. The Briton Frederick W. Lanchester in 1902 is awarded a patent for the first brake disc. However, Louis Renault, in 1903, decides to improve the drum system first, although he’s unable to prevent its crucial disadvantage: When the brake is heavily used the drum heats up to several hundred degrees and expands. As a result, the brake linings no longer have proper contact and the brake isn’t fully effective anymore. Also in 1903,

The first “automobile” in the world: Nicolas Cugnot in 1771 ventures an excursion in the steam-powered vehicle he designed. However, because he forgot to install brakes, he caused the first automobile accident in transportation history

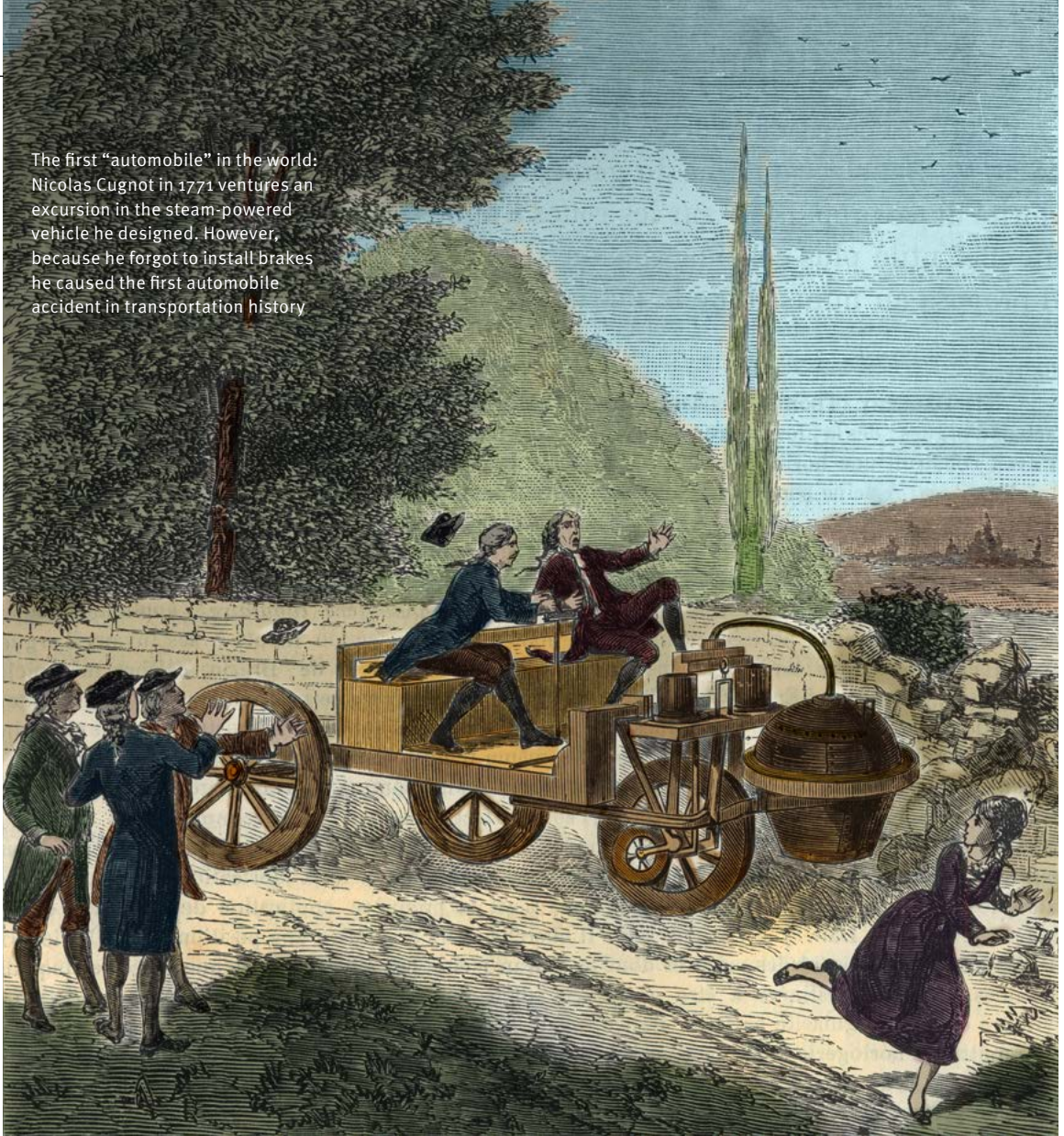

The steam brake of an old steam locomotive shown here operates the way many brakes do as well: friction surfaces – under steam pressure in this case – are pushed against a rotating element to degrade kinetic energy

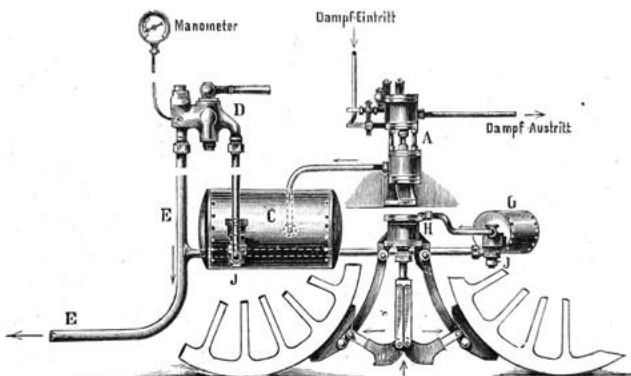

Ernst Sachs introduces the coaster brake (aka backpedal brake) on bicycles. This type of brake is both simple and sufficient so that rim and disc brakes are only introduced on bikes much later.

Braking on rails

On their “Rocket” locomotive from 1829, father and son Stephenson still rely on reverse gear to slow it down and on later locomotives wooden brake shoes are pushed against the wheels. When the trains are becoming longer and heavier the train cars have to be slowed as well. That’s when the days of the brakemen begin who in little cubicles attached to the cars wait for the command to brake and then initiate the process by turning a hand-wheel. Fortunately, railroad master machinist Jacob Heberlein in 1856 is awarded a patent

for a brake that uses the rotation of the wheel axles to push the brake shoes against the wheels via a chain. To make this happen, a rope is pulled across all the cars. When it's tensed, the brakes are released – this marks the invention of the continuous train brake. It's soon followed by the aspirated air or vacuum brake: A vacuum keeps the brakes at a distance from the wheels; without a vacuum the brakes engage. It's not a very efficient system. In 1868, the 22-year-old American George Westinghouse presents the air brake – it will become the worldwide standard.

Modern high-speed trains such as the ICE partly use electromagnetic eddy current brakes to decelerate. On this type of brake, two non-magnetized steel discs (rotors) are connected to the drive shaft. Located in between is the stator with magnetic coils. When the brake is to be applied electric current is induced into the coils which generates a magnetic field that also penetrates the rotors. The eddy currents induced in the rotors generate opposing magnetic fields. Although the technology is nearly wear-free it's effective only at high speeds and therefore has to be assisted by classic shoe or disc brakes. By the way: To be prepared for braking on train tracks that are extremely slippery, express trains today still carry several hundred pounds of sand on board in order to increase the friction between the wheels and the tracks by blowing sand onto them.

Disc brakes begin to make headway in a tank

Back to the automobile: In 1917, the American Malcolm Loughead, the co-founder of the company that later became the Lockheed Corporation, has the hydraulic braking system with brake fluid patented and the master brake cylinder in 1920. The Duesenberg Model A from 1921 is the first automobile with a hydraulic braking system that acts on all four wheels. The first post-World War I Frankfurt International Motor Show in 1923 goes down in history as the "Four-Wheel Brake Exhibition" because this is where the success story of the technology starts. In 1926, 66 percent of all German automobile models are already equipped with brakes on all four wheels – in the same year, the 1926 Adler Standard is the first production car in Europe to be equipped with the Lockheed-type braking systems. By the end of the 1930s, nearly all cars use the oil-pressure brake.

The German "Tiger" tank of all vehicles – fielded in World War II – is the first production motor vehicle to be fitted with disc brakes. The first automobiles to use this technology include a vision-of-the-future on wheels named Tucker Torpedo from 1948. Four years later, Mercedes-Benz tries out an all-new device: In practice for the 24-hour race at Le Mans, the Type 300 SL race sports

cars are fitted with air brakes. Activated by hand, hinged metal panels on the roof are erected to resist the wind. The bolts, however, don't resist the pressure – Mercedes enters the race without the additional brake.

In 1953, a Jaguar using four Dunlop disc brakes wins the 24-hour race at Le Mans – this technology has practically been unbeatable ever since. In the same year, Cadillac, Oldsmobile and Buick equip their cars with power brakes. In the mid-1960s, the first brake boosters start appearing in automobiles, for instance in the Mercedes 300 SL and in the Borgward P 100. The Porsche 911 S in 1966 is the first production car with ventilated disc brakes and in 1971, a BMW Alpina surprises with drilled rotors.

The brake becomes high tech

1973 sees Bosch entering the field of ABS research that was begun by Teldix in 1964, but as early as in the mid-1960s, British automaker Jensen is the first OEM to install a Dunlop ABS – in the small-series Jensen FF. In 1978, Mercedes for the first time offers ABS as an option in a high-volume automobile (S-Class). The system automatically controls the brake pressure so that the wheels are unable to lock and, as a result, the car remains steerable. In 1985, Ford is the first automaker to offer ABS as standard equipment – in its top-of-the-line model Scorpio.



Braking, releasing, braking, releasing: the automatic cadence braking system ABS (anti-lock system) Mercedes introduced in high-volume production in 1978 ensures safe deceleration especially in slippery conditions

2,000 m (6,562 feet)

is the stopping distance of the “Oasis of the Seas” cruise ship in case of an emergency. “That’s extremely short,” says Captain Tor Olsen. Extremely short? Yes, when considering that **ships are allowed a stopping distance of 15 to 20 hull lengths**. Consequently, for the 360-meter (1,188-foot) “Oasis of the Seas,” up to 7.6 kilometers (4.7 miles) would be allowed, in other words nearly four times as much as the ship really needs. “Braking” on water is strictly achieved by reversing the direction of the screws.

Talking about ABS: Since as early as 1952, a hydraulic brake deceleration system, an ABS named “Dunlop-Maxaret,” has existed in aviation. In initial tests, an Avro Canada CF-100 lands safely on ice. Today, every large aircraft uses three brakes: While the plane is still airborne, the brake flaps are extended to reduce lift. After the aircraft has touched ground, reverse thrust is initiated first: The turbines rotate in reverse and start braking when a weight greater than 6,300 kilos (13,889 lbs., for example on an Airbus 320) acts on both landing gears. Disc brakes in the wheels bring the plane to a halt. On the A320, they start working according to plan only at a ground speed of 140 km/h (87 mph).

DECELERATION ASSISTANT THE CLUTCH

Drivers of manually shifted cars have been familiar with this practice for decades: depressing the clutch pedal to engage the next higher gear. In most cases, a Schaeffler component has a major part in this: a clutch from LuK. One in three new cars around the globe leaves the assembly line with a clutch from the Schaeffler brand.

This success story starts in 1965 with the founding of LuK Lamellen und Kupplungsbau GmbH in Bühl in which Dr. Ing. Georg Schaeffler and Dr. Wilhelm Schaeffler have a decisive part. As early as in its founding year LuK

is the first clutch manufacturer in Europe to introduce the diaphragm clutch that will go on to progressively displace the coil-spring types from the passenger car segment. In 1974, LuK is the first clutch manufacturer in the world to offer diaphragm spring clutches – initially, though, only for tractors.

Due to the continuing evolution in vehicle engineering, clutch components today have to meet a wide range of requirements that primarily affect ride comfort, such as quick shifting, vibration damping and noise reduction. Schaeffler innovations like the dual-mass flywheel or the clutch plate with a torsion damper and centrifugal pendulum-type absorber ensure this as well. Modern clutches are

characterized in particular by engine speed strength, high transmission reliability, low installed height, low disengagement forces and long life.

Due to its clutch expertise, Schaeffler has evolved into one of the world’s biggest manufacturers of friction linings. Tens of thousands of linings leave plants in Germany, China, Brazil and South Africa every day. The clutch linings (160 mm to 430 mm / 6.29 inches to 16.9 inches outer diameter) are used in production by all major automotive OEMs. The industrial linings are utilized in diverse applications, ranging from 10-mm (0.4-inch) clutch linings (in data backup equipment) to segments of a clutch-brake combination with an outer diameter of 864 mm (34 inches).

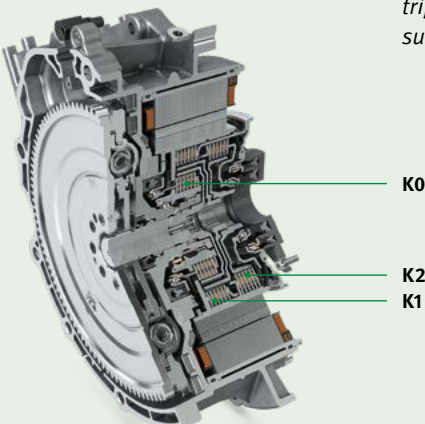

The demands to be met by the clutch system change due to the electrification of the powertrain. Consequently, Schaeffler developed a P2 hybrid module with a wet triple clutch system (K0, K1 and K2) to production level, among other things. This system can almost completely be integrated into the rotor of the electric motor and thus into its installed length. As a result, the entire system consisting of the hybrid module, triple clutch and transmission is very compact.

In the automotive sector, electronic brake force distribution for the front and rear wheels has existed since 1994. In 1995, stability programs are added that automatically slow individual wheels when the driver seems to be losing control. Since 1996, brake assist has been installed as standard equipment, which assists the driver in emergency braking events. Electronics enable Hill Descent Control (HDC) as well, which supports engine braking. The latter describes the mechanical resistance of the engine against torque forced upon it externally.

Eventually, not only the size of automotive disc brakes changed (the largest ones at the moment are Bentley Bentayga's family-pizza-sized front 17.3-inch/440-mm rotors), but so have the materials they're made of. Today, ceramic brakes are regarded as the gold standard: The high-tech brake discs of carbon-fiber-reinforced silicon carbide do not corrode, are insensitive to salt, heat-resistant (which, among other things, avoids brake fading) and lightweight, hardly emit any fine dust particles and are able to last for 350,000 kilometers (217,480 miles). The best systems by now manage to bring a 1.5-ton sports car to a halt from 100 km/h (62 mph) in just 30 meters (98 feet).

Making sensible use of braking energy

The most recent as well as most energetically efficient method to decelerate cars is recuperation. On hybrid and all-electric automobiles (and on other electric vehicles such as electric locomotives) excess kinetic energy is recuperated as electrical energy for charging the traction or electrical system battery. The electric deceleration can account for up to a fifth of the disc or drum brake capacity. As a result, the charging current generated by the technology may amount to as much as 30 percent of the vehicle's range. Electric cars such as the BMW i3 recuperate so intensively that a driver using a predictive driving style may be able to travel nearly exclusively without depressing the brake pedal. Here the technology is becoming increasingly advanced as well: The new Audi e-tron for instance decelerates with a seamless transition between electric and hydraulic braking. Race driver Daniel Abt from the Audi Sport ABT Schaeffler Formula E team was obviously thrilled about the electric SUV following a road test: "The e-tron decelerates by as much as 0.3 g strictly via the electric motors – this is the case in more than 90 percent of all braking events, so the degraded kinetic energy is nearly always converted into charging power. As a driver you don't notice any difference in the effect of the brake that's operating at the moment. The transition is seamless. That's clearly more comfortable than on our Formula E race cars." On the race cars, recuperation only takes place on the driven rear axle whereas a conventional braking system acts on the front wheels. Abt: "This requires a perfect setup of brake

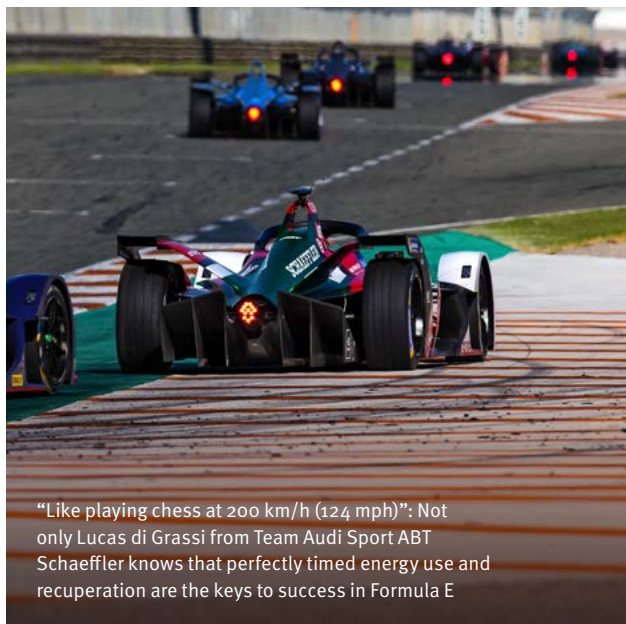

"Like playing chess at 200 km/h (124 mph)": Not only Lucas di Grassi from Team Audi Sport ABT Schaeffler knows that perfectly timed energy use and recuperation are the keys to success in Formula E

1/4 year

a one-family home could be supplied with the electric power that **Schaeffler's partner Porsche recuperated during its 2015 and 2016 Le Mans wins** (some 900 kWh on each occasion).

balance in order to be able to act with precision down to a few centimeters on the narrow circuits."

By the way: Nicolas Cugnot, the unlucky technology pioneer mentioned at the beginning of this article, ultimately went down in world history even without brakes – as the inventor of the first self-propelled vehicle and the person to have caused the first ever traffic accident with an automobile.



THE AUTHOR

Motor editor **Roland Löwisch** has plenty of personal experiences with brakes and braking. The deceleration technology saved his butt on numerous occasions, so researching the cultural history of the brake for this article was huge fun ...

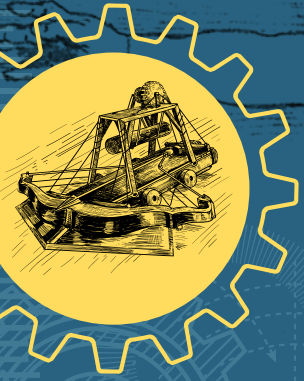

THE DA VINCI FORMULA

No other artist and engineer who passed away a long time ago fascinates us as much as Leonardo da Vinci. However, his much-admired innovation prowess was not a gift from heaven but the result of very specific principles of success which this universal genius systematically pursued. These principles are still powerful innovation boosters today. Here's a selection:

— by Jens Möller

1 SURROUND YOURSELF WITH INSPIRING PEOPLE

Da Vinci was an avid networker – long before the word “networking” became as popular as it is today. As soon as he’d become deeply absorbed in a new subject or project da Vinci would embark on a search for colleagues and experts who were able to fill his knowledge gaps. His notebooks are full of names of a wide range of specialists he was just dying to meet. Even back in his day, he seems to have intuitively understood how important the right social networks are for our professional success. Wherever he lived and worked, da Vinci created an inspiring environment of the leading personages, artists and scientists at the time. These networks and collaborative partnerships made it possible for him to accelerate the further development of his thoughts and ideas.

2 BUILD UPON THE IDEAS OF OTHERS

For a long time, scientists believed that da Vinci’s ideas were the results of his unique ingenuity. Later, though, it was revealed that many of his ideas originally had not been his own at all. A large number of his designs, for instance, were discovered in similar form with other Renaissance inventors. Da Vinci had no qualms about using someone else’s ideas for his own purposes, although he was never interested in just blindly emulating them. Whenever he began to study someone else’s idea he’d do so with the intention to improve and perfect it. Particularly the way in which da Vinci challenged, rethought and enhanced existing styles, theories and techniques shows the brilliance and sense of purpose of his innovative spirit.

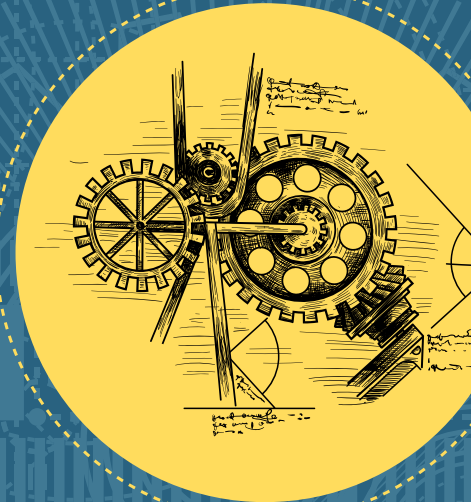

3 THINK WITH A PEN IN YOUR HAND

Da Vinci was a prolific notebook writer and practitioner of “thinking with a pen.” As a hunter of ideas he knew that the next brainwave might strike him anywhere any-time. That’s why he always carried a small notebook with him, which ensured that he’d always be able to jot down all his observations and thoughts and retrieve them quickly as needed. On thousands of notebook pages, da Vinci recorded everything he observed and that gave him food for thought – be it ideas, studies, drawings or personal experiences. He knew about the fleeting nature of our thoughts, so he wanted to capture as many things as possible. The variety of subjects in his notebooks later made it easier for him to create innovative links between areas of interest that were far apart from each other.

4 LINK THE UNLINKED

To gain new findings for his studies of flight, da Vinci came up with the unusual idea of studying fish in water. In doing so, he discovered that the currents of water and air are very similar and applied this discovery to his flying machines. Da Vinci was unbeatable in this discipline known as thinking outside the box: He had the ability to see connections between things that at first glance seem to have nothing to do with each other. Thanks to this way of thinking he also managed to explain the spreading of sound with waves in water and the function of the heart valves by means of floodgates. By deliberately ignoring boundaries and linking diverse disciplines da Vinci came up with his most revolutionary innovations.

FACTS & FIGURES ABOUT DA VINCI

THE UNIVERSAL GENIUS ...

... learns reading, writing and arithmetic with difficulty; never learns Latin.

... is born in 1452 in the Tuscan village of Vinci, Italy. His mother is a peasant, his father a notary.

... in 1485 designs plans for a city with a sewer, garbage disposal and a pump system that supplies every building with water.

... develops numerous machines, incl. the precursors of a helicopter and an automobile, a parachute, an armored tank and a diving bell.

... creates 100,000 drawings and sketches.

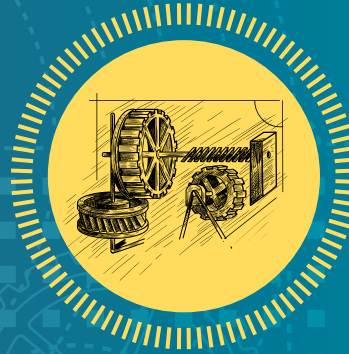

THE RESOURCEFUL FOUNDER

Dr. Georg Schaeffler (1917–1996) is another case in point that proves that the da Vinci formula can work. The founder of the company that bears his name – more than likely unwittingly – applied some of the polymath’s principles.

— Surround yourself with inspiring people

Georg Schaeffler not only sought contact with engineers and technicians in other companies but thought highly of his own employees as well whose brains he’d approvingly refer to as “bio-computers.”

— Build upon the ideas of others and link the unlinked

Lateral thinker Georg Schaeffler did not invent the needle roller bearing. However, its breakthrough was only achieved after Schaeffler had

come up with the idea of individually guiding the needle elements in a cage parallel to the axis. During his productive life, he filed 70 patent applications for his own inventions, the last one just shortly before his death. Its title: “Cup-shaped valve tappet.”

— Pluck up your courage

Like da Vinci, Georg Schaeffler knew that the next inspiration might strike him anywhere anytime. The breakthrough idea of the cage-guided needle roller bearing struck his mind while he was driving. It was based on Schaeffler having challenged the design of existing needle roller bearings. And, like da Vinci, Schaeffler followed his conviction: Together with his team he finished the first prototype in the space of just one day. Shortly afterward, he knocked on the doors of Mercedes-Benz and Adler to

present the innovation. There it was met with enthusiastic response and two major orders were placed, a success that inspired Georg Schaeffler to courageously develop new products. His bon mot that interprets the INA brand acronym as “Immer neue Aufgaben” (“Ever new things to do”) has almost become legendary and is an expression of his pioneering spirit.



PLUCK UP **YOUR COURAGE**

Da Vinci's courage to express revolutionary ideas and to cross the boundaries of established knowledge again and again is another one of his principles of success. All his groundbreaking ideas, observations and inventions would not have been possible without his willingness to reject any form of blind emulation and determination to follow his own convictions. His unconventional pictorial compositions, visionary flying machines and anatomical studies are just a few impressive examples of this creative courage. As a determined "progress maker" he continually challenged the status quo, explored new paths and, as a result, was frequently miles ahead of his competitors. Plus, he paved the way from a purely implemented to an expressive form of art. All of this is all the more remarkable when considering that he lived at a time when any departure from social and religious norms might result in serious if not deadly consequences at any time.

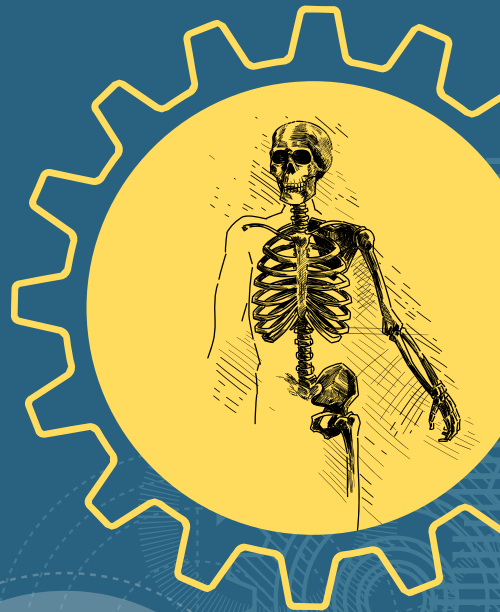

... moves ten times in his life.

... from 1503–1506 paints Mona Lisa, the world's most famous painting today.

... pursues anatomical studies and describes the structure of the human heart, circulatory system and skeleton.

... coins 67 terms just for the motion of water.

... fills some 24,000 notebook pages, many of them written backward in mirror style.

... dies in 1519 aged 67 in France.

... collects 150 books, an impressive number in his day.



THE AUTHOR

Jens Möller is an innovation coach, author and keynote speaker. He encourages people and businesses to recognize, develop and successfully use their innovation potential. For many years, Jens Möller has been studying the life of the Renaissance Man Leonardo da Vinci. He is the founder of the "Leonardo da Vinci Forum," a think tank focused on the future of innovation. His book "Die Da-Vinci-Formel" ("The da Vinci Formula") was published by Redline Verlag.

» I won't put a helmet on for anything above eight minutes

Two-time World Rally Champion
Walter Röhrl about the Nordschleife

5 MINUTES 19.55 SECONDS

— With an absolute best time set on the Nürburgring-Nordschleife Schaeffler and Porsche jointly proved how powerful hybrid concepts are – including in motorsport. In summer of 2018, World Champion Timo Bernhard piloted the Porsche 919 Hybrid Evo through the “Green Hell” at a record pace beating the old record of 6m 11.13s set by Stefan Bellof in 1983 by nearly one minute. “I’m really familiar with the Nordschleife,” said Bernhard, “but in the 919 Hybrid Evo with more than 1,000 horsepower I came to know it in an all-new way. The physical

exertion was extreme due to the centrifugal forces.” Prof. Peter Gutzmer, Schaeffler’s Chief Technology Officer, commented on the sensational record: “As a partner in this project, we’re incredibly proud. This result obviously shows how the technology has continued to evolve since Stefan Bellof’s record lap. We’re convinced that especially the combination of IC engines and electric motors will combine efficiency and driving pleasure in the near future also in production vehicles – and it’ll do so with products from Schaeffler.”

here and now

Living with progress



AT FULL SPEED ON SNOW AND ICE

Many types of winter sports are, above all, about rapid acceleration and maximum possible speed. In the development of new blade or runner materials and chassis bearings for ice speed skaters, bobsledders and lugers, Schaeffler helps achieve precisely these objectives.

— by Laurin Paschek

» ***Even the smallest irregularities or edges in the blade act like a file on the ice and slow down the athlete***

Michael Künzel,
Project Manager Speed Skating at FES

— Speed is the most important factor when athletes are racing on snow and ice in winter. In many disciplines, the low friction coefficient between the sports equipment and the surface enables speeds that are not reached by athletes in summer. A ski gliding over snow usually has only a tenth of the friction that exists between a car tire and the road. In the case of ice skating, the film of water between the blade and the ice reduces the sliding friction to a minimum. Sometimes, only hundredths of a second make the difference between victory and defeat. This is the reason why not only the strength, endurance and skill of the athletes are important in winter sports, but why high-performance sports equipment is essential as well.

In conjunction with the Institute for Research and Development of Sports Equipment (FES) in Berlin, Schaeffler has been developing high-performance components for sports equipment for the national teams of the German Bobsleigh, Luge, and Skeleton Federation (BSD) and the German Speed Skating Association (DESG) for many years. The FES skates, luges and bobsleds benefit from Schaeffler's expertise in the development of high-strength and low-friction materials, the design of rolling and plain bearings, and the analysis of components and equipment using state-of-the-art

measuring technology. The common goal is to develop sports equipment matched to the requirements of individual athletes and to adapt it for every race to suit the conditions such as ambient temperatures, ice and track characteristics.

Skates begging to be filmed

For the German national speed skating team, Schaeffler developed the material for the blades, which is bonded in a carbon fiber carrier called a "torpedo." The blades are in direct contact with the ice and therefore have a very important function. This is because the speed is not only determined by the strength and technical skills of the speed skater, but also by the film of water that is created between the blade and the ice and significantly reduces the sliding friction. The water film is formed, among other things, by the heat generated by the friction of the blade on the ice.

"A low coefficient of friction and low thermal conductivity of the blade steel are therefore important for optimum sliding properties of the skate," explains Michael Künzel, Project Manager Speed Skating at FES. "The heat then remains longer at the contact point, so



that the water film is formed faster and lasts longer.” In addition, high hardness and wear resistance are required. “Even the smallest irregularities or edges in the blade act like a file on the ice and slow down the athlete,” explains Künzel, who used to be a speed skater himself and participated in the 1998 Olympic Games in Nagano and four years later in Salt Lake City. In recent years, FES has been using blade material that is manufactured by Schaeffler from high-performance steel tested in space travel applications and is particularly suitable for these requirements. For the 2018 Olympic Winter Games in Pyeongchang, engineers from FES and Schaeffler developed a new alloy that was used for the first time.

Self-optimizing materials

The German national luge team uses a new material for the runners of its luges as well. Schaeffler developed a new, work-hardened grade of steel for FES that does not require a coating and repairs itself by re-hardening damaged areas due to expansion processes. “Our goal is to precisely match the runners to the needs of the athletes, the track characteristics and ambient conditions by means of heat treatment, grinding and bending,” says Carsten Ludwig, Project Manager Luge at FES. “Coated materials are more difficult to handle because the coating is eventually ground away and the material properties change locally.”

The continuous self-optimization prevents damage to the runners caused by contamination and small stones in the ice channel that would slow down the luge.

Low thermal conductivity of the steel ensures the formation of the water film that also reduces the sliding friction for the lugers.

Bearing as contact agents

In addition, high hardness combined with good toughness is important for the runners. “The geometry of the runners should not change in the ice channel,” explains Ludwig. “For optimum driving dynamics we require the right contact pressure and consistent vertical runner force.” If the runner loses contact with the ice the luge will enter into a ballistic flight phase that will make it impossible to steer it. Spherical plain bearings provided by Schaeffler for supporting the runners also ensure the best possible driving dynamics.



10 medals

were clinched by German athletes in the Olympic ice channel in South Korea in 2018. **In the two-man bobsled, the men and women, respectively, claimed gold. The four-man squads even scored a one-two (picture 1).** The lugers won gold three times, silver once and bronze twice. The German speed skaters, accustomed to success for many years, however, went home empty-handed – in spite of their high-tech blades.

In bobsledding, the sports equipment, which the athletes also call the Formula One cars of winter sports, plays a more important role than in any other type of winter sport. To ensure that the bobsleds remain on track during cornering at up to 150 km/h (93 mph), they are split into two parts – a so-called front cowling and a rear cowling that are connected to each other by an articulation joint and can rotate relative to each other about the longitudinal axis. Among the bobsleds used by the German national team are those from FES that are equipped with high-performance bearings from Schaeffler.

For example, two tapered roller bearings from Schaeffler with a high static load rating and insensitivity to shocks ensure the strength required in the articulation joint. The high rigidity of the bearings and the joint hold the front and rear cowlings in the correct position relative

to each other and prevent deflection caused by the high transverse acceleration, which may amount to as much as five times the acceleration due to gravity. The most important factor, however, is to minimize bearing lash by using the correct preload for both bearings. “As soon as there is backlash anywhere in the bearing, performance is reduced and the bobsled starts losing speed,” says Enrico Zinn, who drives the technical development of bobsleds at FES. Schaeffler is also developing very smooth-running plain bearings for the steering system. “This is important to ensure that pilots can feel the steering directly,” explains Zinn. This is essential for them to develop the necessary sensitivity and to find the racing line that makes the difference between victory and defeat. And when the athletes lift trophies toward the evening sky after international competitions, Schaeffler at least had a small part in their success.

» As soon as there is backlash anywhere in the bearing, performance is reduced and the bobsled starts losing speed

Enrico Zinn, responsible for the technical development of bobsleds at FES

Headed for gold at 150 km/h:
The German four-man bobsled
with Francesco Friedrich,
Candy Bauer, Martin Grothkopp
and Thorsten Margis at 2018
Olympics in Pyeongchang



CLIMATIC CHAMBER PLAYS

A photograph of a car covered in a thick layer of snow, parked inside a climatic chamber. The car is positioned on the right side of the frame. To the left of the car, a camera is mounted on a white tripod. The background shows the interior of the chamber with various pipes and structural elements. The overall scene is dimly lit, emphasizing the texture of the snow.

In tunnels, in snow and rain or at freezing temperatures many miles above sea level: Automobiles and airplanes have to deliver safe and trouble-free performance in all weather conditions and climatic wind tunnels are the key to success in this case. They help engineers to clearly accelerate their development work.

— by Alexander von Wegner



AUDI

At Audi, a climatic wind tunnel was added in early 2008 to complement the Wind Tunnel Center in Ingolstadt. Its thermal range extends from -25°C (-13°F) to 55°C (131°F). A 2.4-megawatt fan generates wind speeds of 300 km/h (186 mph) across the ten-meter (33-foot) test section. Sunlight of up to 1,200 watts per square meter (11 square feet) and rain simulations of 2,500 liters (660 gallons) per hour simulate extreme weather situations under laboratory conditions. For cars with all-wheel drive, a dynamometer is available for each axle with respective output of 250 kW (340 hp). Even the Audi R18 TDI race car was tested in this wind tunnel in 2011. For the 24 Hours of Le Mans and other races, the engineers wanted to know how effectively the cockpit was ventilated, how the windshield worked and where dirt settled on the windshield.

Audi makes its wind tunnel available to partners from the sports arena as well. Among other athletes, skiers and sailors optimize their game with the wind there

As diverse as our means of transportation may be, the expectations of travelers are always the same: getting from A to B as safely and comfortably as possible – be it at -30°C (-22°F) and glacial wind at the North Cape or at 40°C (104°F) and 95 % relative humidity in the tropical heat of Singapore, be it in passenger cars or trucks, or on buses or airplanes.

But how can engineers prepare themselves for such scenarios other than by following the textbook in designing their vehicles and subsequently testing them locally? Climatic wind tunnels are the answer. Modern facilities can be set to temperatures ranging from -40°C (-40°F) to 60°C (140°F) in some cases. Water sprinkler systems combined with wind speeds of 200 km/h (124 mph) and more simulate hurricanes and even snow can easily be produced in a climatic wind tunnel, as well as 1,200-watt heat per square meter (11 square feet) which equates to solar radiation of about 50°C (122°F) similar to the intensity of the Sun in desert regions. The engineers can even vary humidity – tropical conditions are reached at 95 percent.

Ford's wind tunnel test center that was opened in 2018 can even “climb mountains.” As the first of its kind



to do so, the facility simulates elevations of up to 5,200 meters (17,060 feet). For Ford, this is a huge advantage: The automaker, according to its own account, sells more than half of its vehicles to regions located more than 1,000 meters (3,281 feet) above sea level.

80 % less road testing

The pictures delivered by the tests, both on the road and in the wind tunnel, are impressive. In cold testing, massive sheets of snow and ice form on the vehicle bodies and in front of the grilles and air scoops. Is the cooling system still functioning? Will the engine start? How long will it take the heater to warm up the



FORD

*In May 2018, Ford opened a new Climatic Wind Tunnel Test Center in Cologne-Merkenich with a temperature range from $-40\text{ }^{\circ}\text{C}$ ($-40\text{ }^{\circ}\text{F}$) to $55\text{ }^{\circ}\text{C}$ ($131\text{ }^{\circ}\text{F}$). Wind speed of 250 km/h (155 mph) represents a category 5 hurricane. The facility is able to generate up to 95 percent humidity, the solarium operates with up to 1,200 watts per square meter (11 square feet). **It's the first automotive climatic wind tunnel that's capable of simulating elevations of up to 5,200 meters (17,060 feet).** In addition to engine cooling, Ford uses this capability to test cold starting performance and the functionality of automotive fluids in extreme air pressure conditions. The engineers are able to simultaneously test up to ten vehicles. The facility has a capacity of 11 megawatts – enough to supply a town with a population of 2,400 with energy. Ford relies on renewable, certified energy sources from Scandinavia at the wind tunnel test center.*

Makes for arctic cold even in the summer: the re-cooling unit of the chiller's glycol circuit located on the roof of the transformer building (l.)

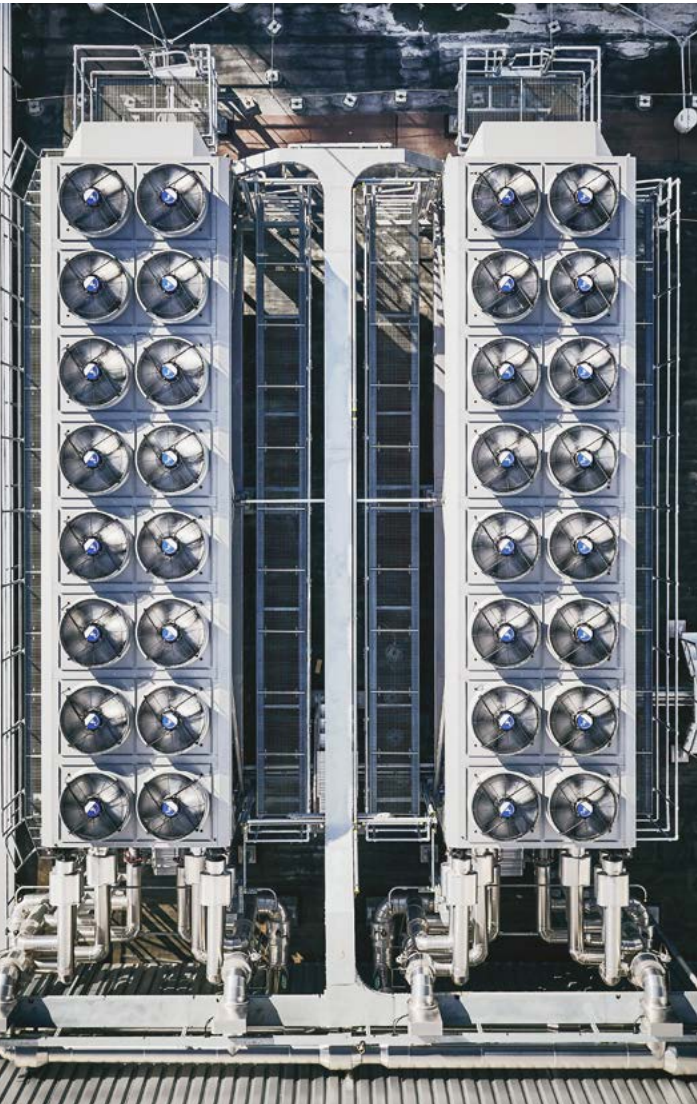

RTA

Rail Tec Arsenal (RTA) is specifically designed for climatic tests of rail vehicles. However, passenger cars, buses or trucks can also be tested in the climatic wind tunnel facility that was built from scratch in 2003 and is **equally suitable for aircraft.** Manufacturers of other products test their technical systems there as well. For instance, weather conditions and wind loads can be simulated for façade segments, for traffic engineering such as signal and transmission systems, railroad switch systems, wind protection walls or for wind turbines or transformers in energy engineering, etc. As an accredited test institute RTA is also able to conduct climate-specific compliance investigations according to international standards. The temperature range

extends from $-45\text{ }^{\circ}\text{C}$ ($49\text{ }^{\circ}\text{F}$) to $60\text{ }^{\circ}\text{C}$ ($140\text{ }^{\circ}\text{F}$) and humidity can be varied between 10 and 98 percent. An overhead rain rig and an icing rig, a spray rig and mobile snow nozzles simulate wetness and ice. Since 2013, the facility has been able to **even generate cumulus and stratus clouds:** 260 nozzles vaporize water with compressed air into icy droplets. The small wind tunnel enables 120 km/h (75 mph) of wind speed and has a 33.8 meter (110 foot) long test section with a frontal area of up to 28.7 square meters (94 square feet). The large wind tunnel is designed for 300 km/h (186 mph), its 100 meter (328 foot) long test section can **even accommodate a train set** and the frontal area has a size of up to 32.2 square meters (106 square feet).



100 meters (328 feet) long and temperatures down to $-45\text{ }^{\circ}\text{C}$ ($-49\text{ }^{\circ}\text{F}$) – RTA in Vienna is one of the world's largest climatic chambers

cabin and to defrost the windows? How long will it take the air conditioning system to cool down a hot interior? How will the windshield wipers perform? Will plug connections and electronic equipment function flawlessly even in conditions of arctic cold and extreme heat?

In their pursuit of answers, the developers could test on roads around the globe for months on end: a major logistical feat. An additional difficulty lies in the fact that natural weather phenomena are hardly controllable and repeatable. This

is precisely why the climatic wind tunnels are so valuable for manufacturers: They make it possible to clearly accelerate development cycles. General Motors, for instance, says a climatic wind tunnel is able to reduce road testing by 80 percent. Volkswagen emphasizes that the communication channels between development teams such as vehicle



safety, design, acoustics and comfort are significantly shortened. Aircraft manufacturer Boeing has been operating an icing wind tunnel since 1991. Previously, aircraft in their certification process had to prove the absence of icing in 60 to 70 flight hours whereas only eight hours are required in the Boeing Research Aerodynamic Icing Tunnel (BRAIT) where wind speeds of 463 km/h (288 mph) and temperatures of 0 °C (32 °F) to -30 °C (-22 °F) are possible.

Climatic wind tunnels, however, are not only important in automotive engineering and aviation. The larger of the two wind tunnels of the Rail Tec Arsenal (RTA) in Vienna, Austria, is so voluminous on a 100-meter (328-foot) test section that it can accommodate a train unit with several cars. The aircraft industry uses the massive facility as well. Helicopters and small aircraft as well as 3.5 meter (11.5 feet) wing segments fit into the huge tunnel in Vienna's Floridsdorf district. The

facility is even able to generate cumulus and stratus clouds.

The consumer benefits as well

Be it acceptance or approval tests in aviation, sophisticated large-scale air conditioning systems like those of trains or the perfect climatic suitability of an automobile: When all the components have also been put through their climatic paces, people will travel in safer, more consistent and more reliable conditions. Interiors featuring enhanced comfort please their passengers with optimized heating, air conditioning and ventilation. When companies test their products in climatic wind tunnels and optimize the fuel economy of individual assemblies and thus entire vehicles this results in higher energy efficiency as well. Consequently, the thermal tunnels make an important contribution to safety, comfort and environmental protection in many industrial sectors. —

VOLKSWAGEN

*In Wolfsburg, a new Wind Tunnel Efficiency Center in an area of 8,800 square meters (95,000 square feet) was opened in 2017. The research center has a new thermo-functional tunnel and a combined aerodynamics and aero acoustics tunnel. The temperature range extends from -30 °C (-22 °F) to 60 °C (140 °F). Wind speed reaches 250 km/h (155 mph) and humidity can amount to as much as 95 percent. The roller dynamometer enables tests of vehicles with output of up to 1,000 kW (1,360 hp). The fan in the thermo-functional tunnel has a diameter of 4.5 meters (14.8 feet) and consumes 2.1 megawatts. **When Volkswagen made history with a first thermal wind tunnel in 1965, performance ratings were clearly different:** It took 2.6 megawatts to achieve the maximum speed of 150 km/h (93 mph) (and even that was 30 km/h (19 mph) faster than a hurricane) and the thermometer reading did not rise above 45 °C (113 °F). Therefore, a second generation of the facility, the thermo-functional tunnel 2, was built in Wolfsburg. **However, it no longer met the constantly growing demands anymore either – so now there's a third generation.***



IN THE EYE OF THE STORM

Cross section of the Mercedes-Benz climatic wind tunnel in Sindelfingen, Germany.

- ① Storage facility for pre-conditioned fuels
- ② 6 conditioning compartments and an adjacent workshop. This is where the vehicles are prepared and heated or cooled to the desired temperature. Subsequently, the vehicles are taken directly and without external contact to the climatic wind chamber, so the tests can immediately begin there
- ③ The turbine generates any desired wind up to hurricane intensity (200 km/h) (124 mph). Even at wind speeds of 100 km/h (62 mph) a human being can no longer stand safely
- ④ In an area of 8 x 2.5 meters (26 x 8 feet) the radiation intensity of 200–1,200 watts/m² (11 sq ft) can be controlled. A comparable peak value outdoors can only be found at extremely hot locations such as in Death Valley (USA)
- ⑤ Test facility accommodating passenger cars/commercial vehicles from the Smart to the Sprinter
- ⑥ The so-called “hot road” is continually variable from 50 to 70 °C (122 to 158 °F). It serves to simulate the heat on a road in summer
- ⑦ 4-wheel roller dynamometer. The total capacity (max. 780 kW) is sufficient for simulated speeds of up to 265 km/h (165 mph)
- ⑧ Humidifier (55–95 % humidity)
- ⑨ Heating/cooling element with a temperature range from –40 to +60 °C (–40 to 140 °F)
- ⑩ Snow/rain simulation. Hourly precipitation of up to 80 l/m² (21 gal/11 sq ft) can be equally simulated as the worst blizzards in which snowflakes hit the test vehicles at a speed of 200 km/h (124 mph)

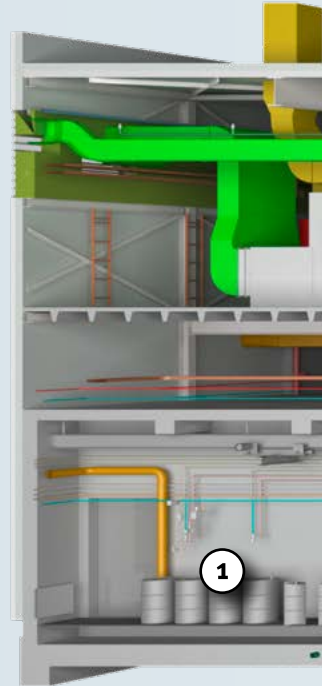

MERCEDES-BENZ

The Stuttgart-based automaker has a cold tunnel for the temperature range between –40 °C (–40 °F) to 40 °C (104 °F) and a warm tunnel for the range between –10 °C (14 °F) and 60 °C (140 °F). Thanks to two-axle roller dynamometers and speeds of up to 265 km/h (165 mph) even sports cars can be tested. Mercedes-Benz does not view the facilities as a substitute for road testing but as offering the major benefit of clearly reducing the number of road tests and being able to approach them with far better preparation. Variants of individual components can already be rejected under laboratory conditions. The accel-

eration is tangible because the engineers no longer have to conduct lengthy preliminary road tests. Even so, the resulting technical maturity of the prototypes is higher. In addition to vehicles with IC engines, the company can test models with fuel cells in its climatic wind tunnels. Air conditioning, ventilation or component tests are equally in focus as the simulation of long downhill driving in high summer temperatures in order to test the loads acting on the braking system. Even road surface heat can be set to temperatures between 50 and 70 °C (122 °F and 158 °F) in order to take this real-world factor into account as well.

M

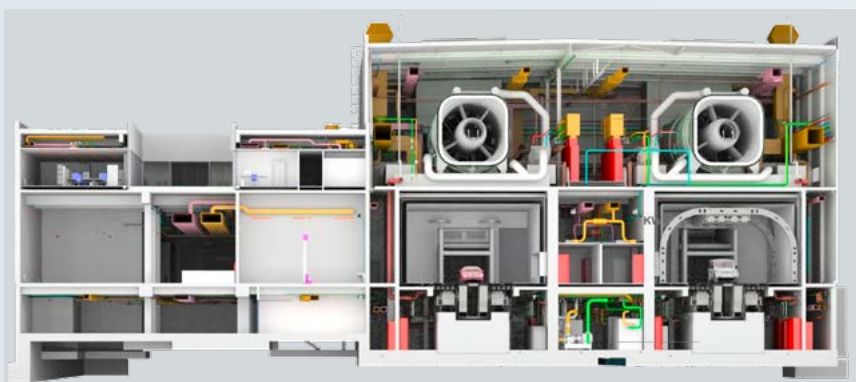
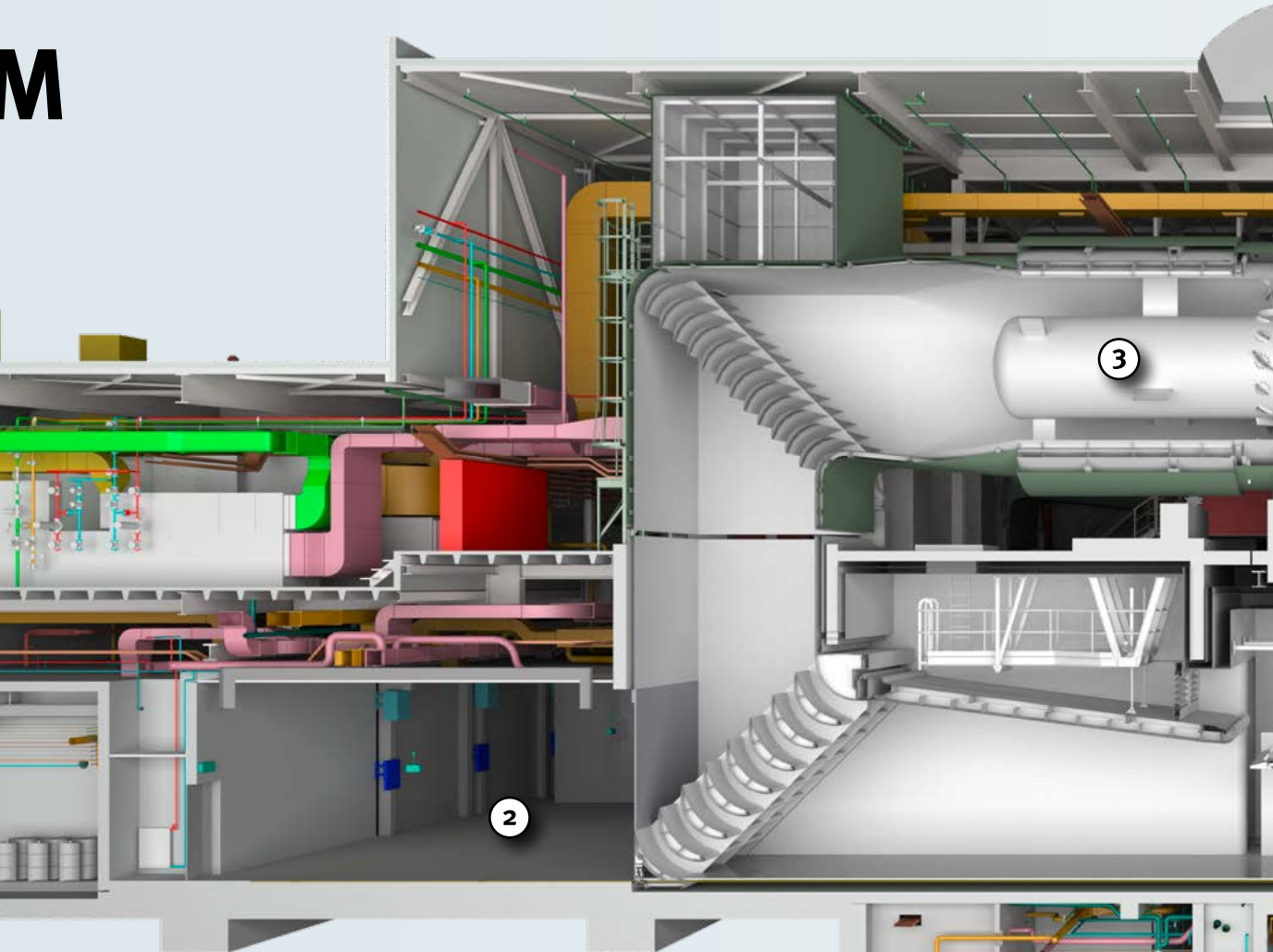

The front view in the cross section reveals the two side-by-side climatic tunnels “warm” (–10 to 60°C / 14 to 140 °F) and “cold” (–40 to 40°C / –40 to 104 °F)

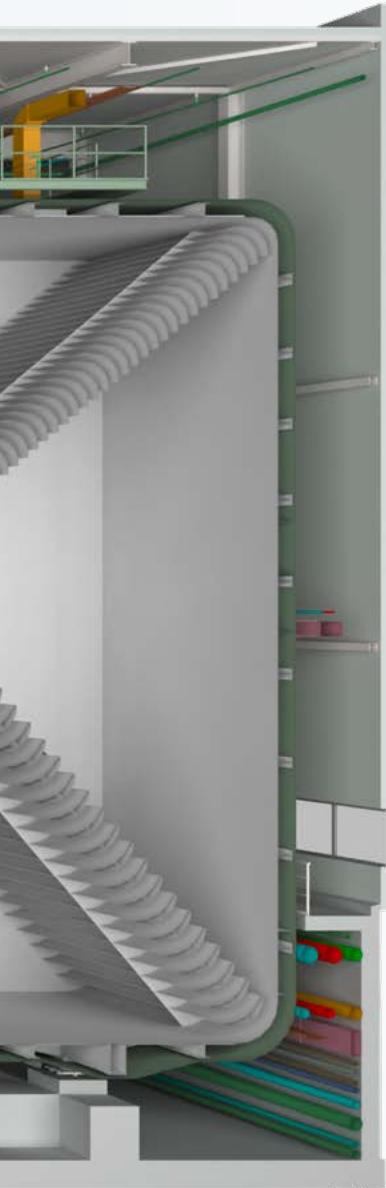

FROM THE EIFFEL TOWER TO THE CLIMATIC CHAMBER

A free fall precedes the first wind tunnel: Gustave Eiffel is one of the first engineers to get to the bottom of aerodynamics. In 1905, he has various metal plates dropped from the second platform of the tower that's named after him (pictured above). Although the tests deliver convincing results, the method heavily depends on the prevailing weather conditions. That's why, in 1909, Eiffel moves to the Laboratoire Aerodynamique Eiffel that he designed himself – a type of open wind tunnel that aspirates outside air via a turbine – including ambient temperature and pressure fluctuations. Consequently, precision soon reaches its limits. The situation with the test method developed by the German engineer Ludwig Prandtl (center) at roughly the same time is different. In his investigation of fluid dynamics, Prandtl uses a closed circuit in which air is accelerated. His results are not only more precise but the tests are repeatable as well. This design soon evolves into an international standard. Even today, Ludwig Prandtl is still regarded around the world as the “father of aerodynamics.” At the beginning of the 20th century, research is focused on the fledgling field of aviation. However, after the



First World War, more and more automobiles feature streamlined designs too (pictured below: Edmund Rumpler's “Tropfenwagen” (“Drop Car”) from 1921 with a drag coefficient of 0.28 that's still exemplary today). In 1965, VW in Wolfsburg combines a climatic chamber and a wind tunnel for the first time. The wind and weather simulator would remain a technological trailblazer for many years.



For the development of the electromechanical roll stabilizer, Schaeffler already used the “test rig of the future,” a joint project with Fraunhofer Institute LBF. In this case, the test environment as well as the product itself is shifted into the computer as a digital twin. This yields a significant reduction of cost-intensive rig testing times and accelerates processes in general because obstacles can be detected and their causes identified early.





FULL STEAM AHEAD

Cast off! The world is embarking on a journey into a new age: research, development, manufacturing, logistics – the pace is accelerating in all areas – and at Schaeffler as well.

— by Leopold Wieland

— Electric bicycles are dashing across the marble floor, e-boards are unfolded and readied for use, laptops and tablets passed around. Welcome to the Schaeffler Venture Forum 2018! For an event billed as “teaming up for greater speed, agility and boldness,” the technology group invited startups from relevant sectors such as “Smart Factory/Digitalization of Production,” “„Mobility Concepts,” and “New Material Solutions” to the company’s headquarters in Herzogenaurach. The objective of the event: “We check out startups in terms of their interest to Schaeffler with respect to technology, business model and entrepreneurship. If everything fits we’ll go on to jointly develop the business idea further,” says Professor Tim Hosenfeldt, Senior Vice President Technology, Strategy & Innovation at Schaeffler.

Innovative startups are keen to team up with strong partners such as Schaeffler. A total of 113 applicants from 24 countries entered their ideas, vying for participation in the Schaeffler Venture Forum 2018. 14 of them were subsequently invited – to a meeting on an equal footing because Schaeffler is aware of the importance of these young companies. “The world of the future will be intensively shaped by new ideas, technologies and business models,” says Professor Peter Gutzmer, Schaeffler’s Chief Technology Officer, “and there’s a Global Startup Movement that’s in the process of tapping the potential of this future world. We’re seeking to get in touch with these young companies and trying to find new ideas, new business fields and new approaches together with them.”



Schaeffler checks out startups: Chief Technology Officer Peter Gutzmer (right) and chief innovation strategist Tim Hosenfeldt (center)

Like with Autinity Systems, an IT company from Chemnitz, Germany, that Schaeffler acquired and integrated following its first Venture Forum 2017. As a result of this integration, Schaeffler achieved clearly faster progress in the field of digital condition monitoring and machine data acquisition than the group would have on its own. And this is just one example of many that show how Schaeffler is becoming more agile and nimble in order to successfully stand its ground in the marketplace.

Digitally accelerated research and development

The company's 18 in-house research and development centers have been and will continue to be key acceleration factors. 6,400 employees there continually invent and

create new products and services and optimize existing technologies. Schaeffler filed 2,383 patents in 2017 alone which puts the company in position two of the national ranking, even ahead of all automotive OEMs and electronics giant Siemens. With that, Schaeffler underscores its role as a global innovation leader particularly in the areas of electric mobility and Industry 4.0 (aka IIoT and smart factories). In addition, Schaeffler has established smart services with efficient, digital solutions as new business segments in recent years.

In order to develop machines and equipment faster and therefore more cost-efficiently, Schaeffler utilizes leading-edge calculation and simulation programs. Only when all components interact as planned in virtual test operations the so-called "digital twins" turn into "real-world twins." These prototypes already

exhibit an extremely high level of maturity which significantly shortens the path to the final product. Thanks to its comprehensive simulations across the entire product lifecycle (design, build, operation, maintenance, recycling) Schaeffler operates more efficiently, accurately and faster. This plays a major part in reducing time-to-market and the company's ability to offer products at lower costs.

Close collaboration with customers

Another basic savings and acceleration effect of Schaeffler's digital-based development work: The customer can be – and is – flexibly involved in every step as the project progresses. Function, engineering design, material types and strengths: Customers have direct influence on



Virtual creation and testing precedes real-world build: In product development, Schaeffler employs leading-edge calculation and simulation

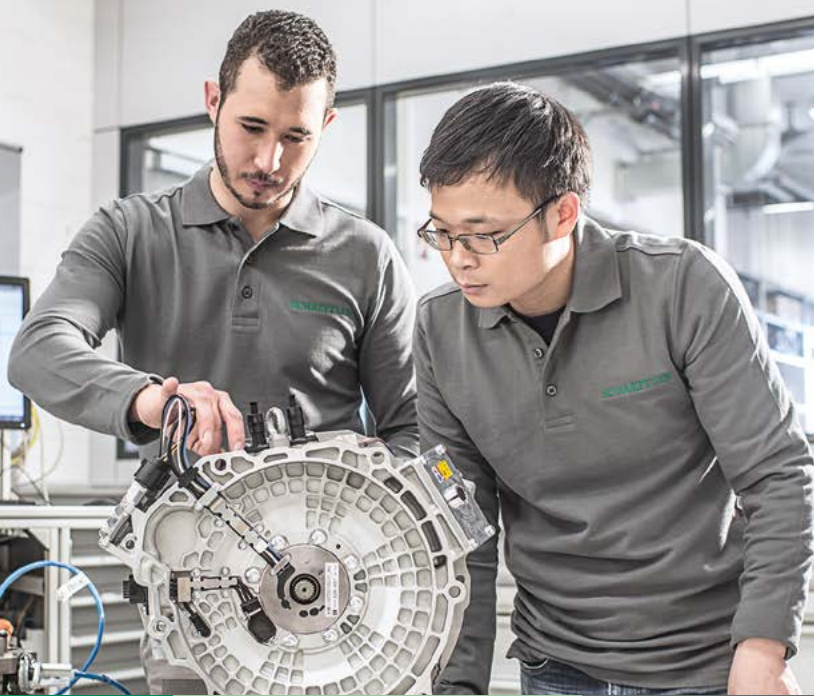

18

in-house research and development centers are operated by Schaeffler worldwide

2,383

new patents were filed by Schaeffler in 2017

6,400

of the 92,000 employees are engaged in research and development for Schaeffler

» If we want to master the challenges of the future we will only be able to do so in concert with our employees

Corinna Schittenhelm, Chief Human Resources Officer

every detail during the research and development stage. Thanks to the realistic Schaeffler simulations they can continually track the project and decide: What are the capabilities of my new product in this or that type of design? How long will it last in this or that configuration? Plus: What will be the resulting costs of either choice to me? As a result of this custom-tailored, adaptable and ultimately faster process, both development partners, Schaeffler and the customer, save time and money.

“Factory of tomorrow,” a major milestone for the industrial world

Schaeffler, however, not only aims to become faster and more agile in its development activities. In its first “factory of tomorrow” worldwide, the Group is planning to

implement its ideas for accelerated production processes. In November 2017, the construction project for this “factory of tomorrow” was launched in Xiangtan, in the Hunan province in Southeast China. The plant is planned to be opened in 2019. The new facility in Xiangtan takes cues from the structures of a butterfly. The four halls form the wings whereas the buildings of the body will accommodate office areas, among other things. Due to this configuration, the shop floor stays in close exchange with all supporting, production-facing functions through to finance and purchasing. In addition, internal communications are enhanced in this way. The shop floor features a modular design, so that new modules for production lines and product portfolios can be easily added. Currently, Schaeffler is planning to produce systems for engines, transmissions



Put to the test: At Schaeffler's Venture Forum, selected inventors present their innovative technologies. Those who manage to impress at the event have optimum chances of collaborating with the Group

and suspension systems for the automotive industry in its "factory of tomorrow" in China.

The "factory of tomorrow" just like the even more progressive, largely self-organized autonomous shop floor based on cybertronic systems (see also related "mecPro2" info element), ultimately functions only as well as the people working for and in it. So it comes as no surprise that the "Qualification of Tomorrow" and "New Work" initiatives are important pillars of Schaeffler's forward-thinking program billed as "Agenda 4 plus One." For Corinna Schittenhelm, Schaeffler's Chief Human Resources Officer, it's clear that "If we want to master the challenges of the future we will only be able to do so in concert with our employees."

One aspect of New Work: It's no longer important where work is performed but how. "We don't have a presence culture but a project culture," says Bernd Wollenick, Director Special Machinery in Erlangen. Working on the spacious roof terrace in summer? Why not! A good mood

produces good results. "We've made a giant leap in terms of output," reports Wollenick, "the efficiency of the work done has increased."

Faster and more flexible customer deliveries

In 2018, Schaeffler in the field of logistics demonstrated the consistency, speed and agility with which the Group is headed for the future in particularly impressive ways. Only ten days after officially opening the European Distribution Center (EDC) in Kitzingen, Schaeffler launched its next ultramodern new construction project in Halle/Saale: an assembly and packaging center for its Automotive Aftermarket business. In spring of 2020, the new facility, just like the EDC Central, is planned to be launched after a 20-month construction period. Capital expenditures for both of these large-scale projects amount to 290 million euros (110 Kitzingen, 180 Halle).

The main objective for Schaeffler in Kitzingen and in Halle is to

accelerate the warehouse pick & place, repackaging and reshipping processes. Logistics experts refer to this as "accelerated throughput times." The key purpose pursued by the new large-scale warehouses is to make faster and more flexible customer deliveries and to thereby enhance customer satisfaction. In Kitzingen, it works like this: While in the past, goods for Schaeffler's industrial customers were shipped from up to 17 different dispatch points, it's now down to one and the goods will reach the recipient within 24 to a maximum of 48 hours after they've been ordered. Digital, fully automated processes, plus state-of-the-art equipment with high-bay racking, a small-parts store, electric pallet ground conveyors, robotic applications and a sequencing tower are the enablers.

Due to its new assembly and packaging center in Halle an der Saale, Schaeffler optimizes its processes in the Automotive Aftermarket sector and significantly shortens throughput times. Like Kitzingen, the so-called AKO (Aftermarket

Kitting Operation) is conveniently located in the center of Germany and has a highly modern infrastructure. With its fully automated pallet warehouse, the Halle location is planned to evolve into the key supply point for all European regional warehouses of Schaeffler Automotive Aftermarket as well as the regional warehouse for Germany, Austria and Switzerland – with 40,000 different articles for passenger cars and commercial vehicles. 70 million spare part kits are planned to be shipped from there per year. “This center

enables us to meet the demands of our customers even more obligingly, faster and flexibly,” says Michael Söding, CEO Automotive Aftermarket at Schaeffler.

Award-winning new logistics software solution

Schaeffler’s logistics have become faster and more agile due to ATS as well. ATS stands for call-off and transportation system. This new digital, smartly connected user

software solution was recognized as one of the best logistics innovations in 2018. ATS, which Schaeffler is currently rolling out in more and more of its plants around the world, results in significant improvements in terms of planning, control, monitoring, accuracy and cost efficiencies in highly complex processes in the flow of goods from the material warehouse to the shop floor. “I’m convinced that with nearly all Schaeffler products, all Schaeffler services as well as with Schaeffler processes in manufacturing more and more mobile applications such as ATS will be utilized,” emphasizes Schaeffler’s CEO Klaus Rosenfeld.

Chances that an innovation from the Schaeffler Venture Forum 2018 will also benefit from the accelerated processes of the technology group are good. Schaeffler’s Chief Technology Officer Gutzmer at least is confident that it will be possible to continue two or three of the startups that presented themselves there in close collaboration.



PROJECT MECPRO²

The mecPro² Industry 4.0 research project funded by the German Federal Government, in which Schaeffler has a leading part, is the acronym for “model-based development process of cybertronic products and production systems.” Schaeffler has elaborated it jointly with TU Berlin, TU Kaiserslautern, CONTACT Software, Continental, Daimler, :em engineering methods, Siemens and Unity. The basic principle of mecPro²: Due to a shared system model, the product and production model (e.g. a cylinder head and a cylinder head production machine) are viewed as a logical unit, developed concurrently and built in a connected process. The objective is to more effectively integrate the diverse engineering disciplines in order to optimize development processes and avoid redundant work and errors. Ultimately, machines that automatically and autonomously communicate with each other by means of artificial intelligence are planned to autonomously and collaboratively manufacture products.



THE AUTHOR

Leopold Wieland is an editor at communications agency Speedpool in Hamburg. Acceleration has always been a topic of interest to the motorsport journalist. For him, it was initially just a matter of getting rid of the support wheels on his children’s bicycle. But that took a while, so he finds the rapid pace at which today’s industrial world is storming forward on new paths all the more fascinating.



A SHOWCASE FOR ACCELERERA

There's a lot of talk about technology transfer from motorsport – automotive and industrial supplier Schaeffler in the Schaeffler 4ePerformance concept car demonstrates what such transfer can look like. The project has resulted in a veritable acceleration giant that puts its awesome 1,200 horses on the road in highly intelligent ways.

— by Carsten Paulun



TION

— It's a completely normal day at the high-speed proving ground in Nardo, Italy. Crickets are chirping and the sun is not yet burning down with a vengeance. It's springtime. From the pit lane a pretty inconspicuous vehicle is approaching the test track. It's reminiscent of a classic touring car. But why is it so quiet? The answer's simple: It's an electric vehicle, albeit not just any electric vehicle but Schaeffler's 4ePerformance concept car, with Lucas di Grassi at the wheel. When the

2016/2017 Formula E Champion floors the accelerator pedal white smoke comes shooting out of each of the four wheel wells, engulfing the Schaeffler 4ePerformance like the smoke does the chimney of the Sistine Chapel following the election of a new pope. It's just that here it's not an earthly head of church that visibly emerges but an electric sports car with a green and white wrap. The 4ePerformance breaks the 200-km/h (124 mph-) mark from rest in less than seven seconds. For

comparison: The German "auto motor und sport" magazine lists the Porsche 918 Spyder hybrid sports car at 7.4 seconds as the fastest 0-to-200 production-level sprinter.

Four electric motors, each delivering 300 horsepower!

Video footage from Nardo shows a fully focused, excited Lucas di Grassi trying to judge what experience at the limit the next few minutes

are holding in store for him. His racing gloves have a firm grip of the wheel; his back is seeking support in the sports seat. The first corners are coming up in a rush; the professional racer is increasingly loosening up, relishing every directional change. “Super-cool! Thanks to the unique all-wheel drive system I’m able to control the 4ePerformance very easily no matter how sharp the turns are.” The concept of the 4ePerformance makes this possible: Every wheel is driven by a dedicated electric motor. They have been adopted from the original Formula E race cars that Lucas di Grassi and Daniel Abt contested their races in during the 2015/2016 season. Every one of them delivers 220 kW/300 hp – in other words 1,200 horses combined. A much more important factor of the car’s exceptionally dynamic cornering performance, though, is the fact that the speed and power output of each motor, and consequently each wheel, can be individually controlled and in this way, the 4ePerformance supports the driver’s steering input. The technical term for it is torque vectoring and on conventional vehicles requires a complex differential on the driven axle. On the 4ePerformance, sophisticated electronics developed by Schaeffler provide the gain in safety and driving pleasure.

» The Schaeffler 4ePerformance has brought its 1,200 horses back under the spotlights and this time around the sedan-gone-race car [...] converted to sip on electron juice is here to hunt down supercars”

autoevolution.com

» The devil wears Prada? Perhaps – but its tank is no doubt filled with electric juice!

Autobild sportscars

Power output can be varied between the front and rear as well, for instance, to provoke intended rear oversteer. “These are the most controlled drifts I’ve ever done,” Lucas di Grassi enthuses and by now is mastering each turn quite casually with just one hand on the steering wheel.

Learning from extremes

“For Schaeffler, this vehicle is a test laboratory on wheels thanks to its free scaling options for the drive power,” says Simon Opel, Director Special Projects Motorsport at Schaeffler, and adds: “We are currently testing and developing our own driving dynamics control system, which is based on physical vehicle and wheel modeling. We have been learning a lot especially in the area of software-based driving dynamics control systems.” Chief Technology Officer Prof. Peter Gutzmer also views the 4ePerformance as an ambassador: “In the same way that Schaeffler has contributed its technical expertise to Formula E from the very beginning, the technology group plays a pioneering role and is a partner for components and complete system solutions when it comes to applying electric mobility to volume production vehicles and putting them on the road.”

And this ambassador does in fact accelerate the heart rate not only of motorsport aficionados. The internet portal autoevolution.com, for

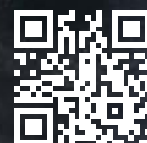
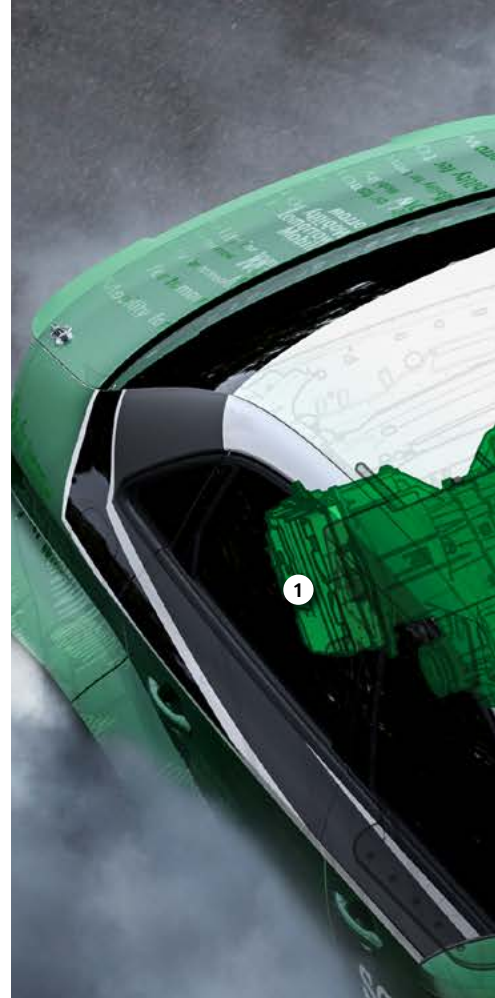

More about the development of the 4ePerformance and Lucas di Grassi’s test drive

1 year

elapsed between project launch and rollout

1,200 hp

Four e-motors, each with 220 kW/300 hp

220 km/h

top speed (due to short final drive ratios)

1,850 kg

is the weight of the prototype (incl. the 600-kg/1,323-lb battery)

in less than 7 s

from 0 to 100 km/h (62 mph)

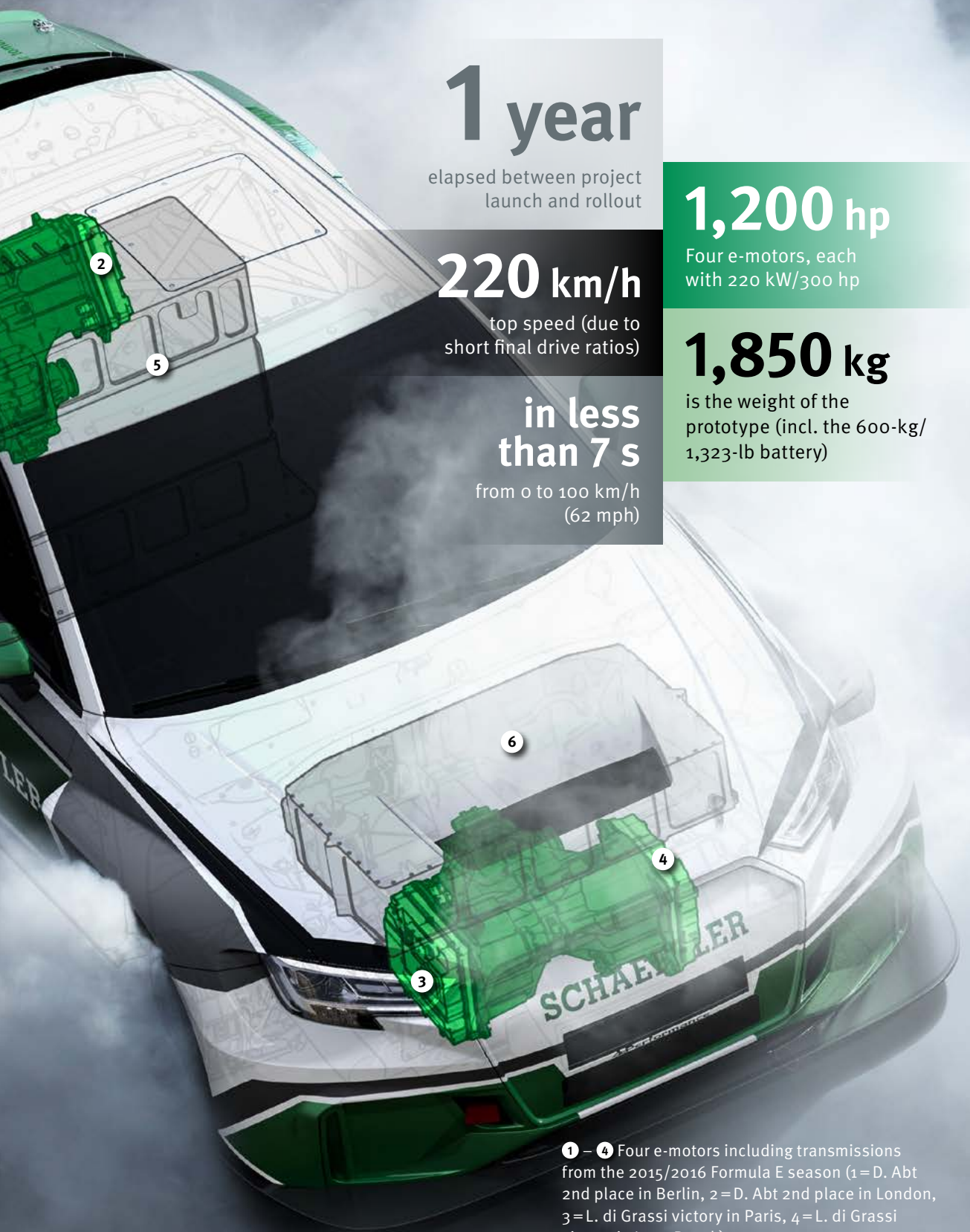

1 – 4 Four e-motors including transmissions from the 2015/2016 Formula E season (1 = D. Abt 2nd place in Berlin, 2 = D. Abt 2nd place in London, 3 = L. di Grassi victory in Paris, 4 = L. di Grassi victory in Long Beach)

5 & 6 The battery (64 kWh) for better weight distribution was split 1/3 (above the front axle) to 2/3 (behind the front seats)

DANIEL ABT ESTABLISHES A UNIQUE RECORD

The 4ePerformance sets new acceleration standards and thanks to torque vectoring catapults hot cornering drifts into a new dimension. That even fires up Daniel Abt (right), Formula E pro and Lucas di Grassi's teammate at Audi Sport ABT Schaeffler: "Wow, such acceleration. It's the most awesome thing I've ever experienced. I never want to stop that stuff!" Well, he won't have to because Abt gets to up the ante. On the Papenburg proving grounds in the German state of Lower Saxony, he initially tries out "pleasure mode": depress the key on the race steering wheel for five seconds, briefly pull the shifter and rev up. The 4ePerformance starts screaming, the left wheels rotate forward, the right ones backward – and the 4ePerformance begins to gyrate, impressively demonstrating the powerful performance of torque vectoring.

But then even the horsepower pro starts sweating: He wants to break the record in reverse driving. It's currently at 162 km/h (101 mph). In his attempt to break it, Daniel Abt has to be able to rely on the control electronics. Corrections on the steering wheel are practically impossible because the 4ePerformance would immediately fly off the track. First attempt at 100 km/h (62 mph), second attempt at 132 km/h (82 mph) and third attempt at 170 km/h



(106 mph) – the old record has already been broken, but then Daniel Abt ups the ante once more, aiming in reverse mode to beat a Porsche 911 GT2 RS traveling forward in the acceleration sprint. Abt admits: "I'm really scared!" Both drivers floor the pedal and at 178 km/h (111 mph) Daniel Abt passes the Porsche. Abt still hasn't had his fill, though, he wants to crack the 200 km/h- (124-mph-) mark. In his fifth attempt, he finally does it: 209.7 km/h (130.3 mph)!



Out of this world:
Scan code to view
(German) YouTube clip
of Abt's record drive



instance, writes: “Well, the Schaeffler 4ePerformance has brought its 1,200 horses back under the spotlights and this time around the sedan-gone-race car [...] converted to sip on electron juice is here to hunt down supercars.[...] the aural side of the monster is almost as impressive as its acceleration. And we’ll have to get used to this kind of soundtrack.” Indeed, the 4ePerformance does not emit sounds of silence even though there’s no IC engine roaring here. Instead, there are various fans and pumps at work. The battery that’s split for better weight distribution, for instance, heats up extremely in the process of delivering electricity. Schaeffler and vehicle tuner ABT that constructed the 4ePerformance use a non-conductive fluid as the coolant. If the battery were damaged in a potential crash in spite of extensive safety precautions this would prevent dangerous short circuiting. The oil pumps of the dry sump lubrication system make their presence known by emitting a distinctive wail. They ensure that wear on the input spur gear units that have no differentials is minimized to the extent possible. Each wheel has its own transmission, its own electric motor and its own power electronics. Each motor operates with up to 14,000 revolutions per minute and all four wheels combined slam an incredible 1,280 newton meters on the road.

Weight? A minor matter ...

The high torque development in combination with the control electronics elaborated by Schaeffler quickly makes you forget the car’s weight – the 4ePerformance tips the scales beyond 1,800 kilograms (4,000 imperial pounds). “auto motor und sport” editor Jens Dralle puts it in a nutshell: “Which really doesn’t matter because in this car you don’t feel like you’re approaching a turn, a chicane [or] the end of a straight. No, they just smack you right in the belly. A swelling wail and pow! something or other is coming up again:

» Projects such as the Schaeffler 4ePerformance accelerate the development of new technologies – and in addition emotionally charge the topic of e-mobility in a fascinating way

Prof. Peter Gutzmer, Deputy CEO
and Chief Technology Officer of Schaeffler AG



Racing line: Thanks to the unique all-wheel drive with precisely adjustable torque vectoring the 4ePerformance permits high-speed drifts

braking, steering, accelerating or whatever. It all happens at awesome speed. Anything you normally approach by accelerating more or less vehemently now simply materializes in front of you.” Or, to put it in the words of “Autobild sportscars”: “A heavy depression of the pedal on the right and this machine will polish your cerebral cortex from the inside; straighten out any wrinkle and vaporize your conventional IC engine manners almost faster than it does its tires. The devil wears Prada? Perhaps – but its tank is no doubt filled with electric juice!”

Impressive, though, are not only the car’s forward and lateral acceleration. Equally important is its negative acceleration, in other words the brakes. If Schaeffler and ABT had left the job of braking up to the production system, the 4ePerformance, in spite of an all-out braking event at full throttle, would have reached 100 km/h (62 mph) from rest in just

seven seconds! Instead of the white smoke we would have seen red-hot brake rotors. The braking system was completely built from scratch to match the motors’ power output. Jürgen Voigt, chief editor of the “Auto-Zeitung” test desk, describes the result as “an awesome effect.”

And what is the 4ePerformance for its inventors? In Schaeffler’s book, it is a key to developing new ways of making electric cars real fun.



THE AUTHOR

As a motor journalist with gasoline running in his veins Carsten Paulun can never get his fill of power to direct with his foot. Combining it with his second passion, sustainable energy production, makes it even sweeter.

THE WORLD



The ATLAS detector at CERN with a length of 46 meters (151 feet) and a diameter of 25 meters (82 feet) is the largest detector in elementary particle physics built to date

MACHINES

Physicists use particle accelerators to smash tiniest particles against each other in a quest for new answers to humanity's big questions. Particle accelerators are even utilized to fight cancer and to produce computer chips.

— by Dr. Christian Heinrich

— The world around us, our bodies and even the paper of this magazine – what exactly does all this consist of? Sure, we know by now that everything's made up of atoms. And atoms consist of even smaller components, of electrons, neutrons and protons. But what are the absolutely smallest components that everything is made up of? Or could

there be parts even smaller than that? And what about the very beginning, how did the universe suddenly form out of nothing? To answer humanity's biggest questions, scientists around the world examine the smallest components of the cosmos and the so-called particle accelerators are their most important tools in their quest for knowledge.

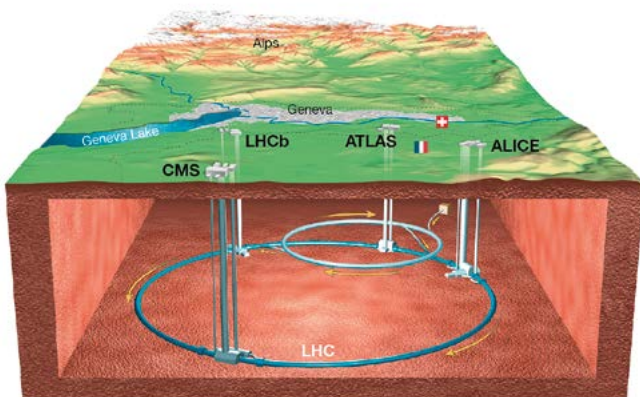

The CERN particle accelerators are located 100 m (328 ft) deep in the ground below Geneva. The biggest one, the Large Hadron Collider (LHC), has a circumference of 26.66 km (16.56 mi). In December 2018, it was shut down for a two-year period of maintenance and upgrading

As the name says, they accelerate charged particles like protons or atoms so that they collide with each other at an enormous speed. When this happens scientists attempt to catch a brief glimpse of new, even smaller particles that may have been created in the process.

It's the length that does it

There are various types of particle accelerators that make it possible to achieve respectively high velocities of the particles.

The linear accelerator is a very long pipe with a wall consisting of various so-called drift tubes. These drift tubes generate a constantly changing voltage. Similar to the way a magnet works, the particle is attracted by the respective front drift tube and repelled by the rear one. In this way, the particle accelerates with every drift tube it passes. To achieve the desired velocities, a linear accelerator has to be several kilometers long.

The synchrotron operates according to a similar principle. However, it includes magnets that slightly divert the particles. This allows them to be guided on a type of circular path which they travel on over and over. While this enables high acceleration, it also requires a lot of space because the bends in the pipes must not be sharp. The world's largest synchrotron-type particle accelerator, the so-called Large Hadron Collider (LHC), is located near Geneva, Switzerland, on the premises of the

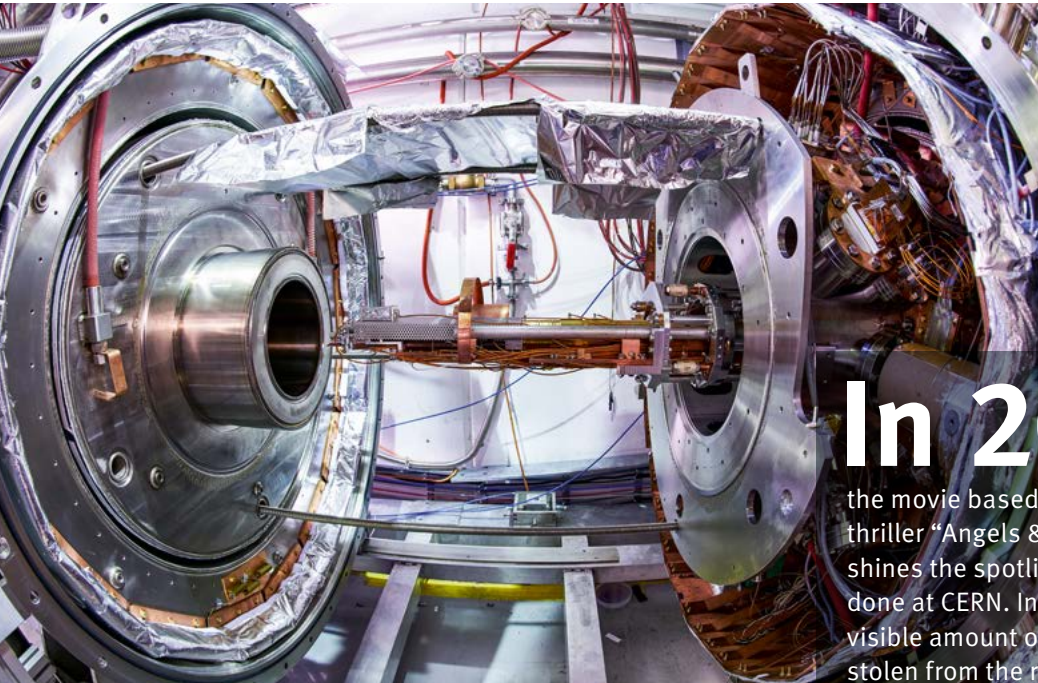

In 2009

the movie based on Dan Brown's thriller "Angels & Demons" shines the spotlight on the work done at CERN. In the book, a visible amount of **antimatter** is stolen from the research center – which is pure fiction. Although about one million "antiprotons" per year are in fact produced at CERN it's **impossible to produce the quantity shown in the movie**. It would take one billion years just to produce one gram (0.03 ounces) of antimatter.

3,000 people

work at CERN, making it the **world's biggest research center** in the field of particle physics. Even larger is the number of visiting scientists: More than 10,000 experts from 85 nations are involved in CERN experiments of the "world's largest knowledge machine." The things they're looking for include the so-called super-symmetry (SUSY) particles that might also provide an **explanation of the Dark Matter** that holds universes together. Tracking them down is even trickier and more energy-intensive than the confirmation of the Higgs bosons.

European Organization for Nuclear Research (CERN) and has a length of nearly 27 kilometers (17 miles).

On a collision course at the speed of light

However, not only the size of the accelerators is breathtaking in the light of the tiny particles. The design of these systems is extremely complex as well. It takes 1,232 magnets, each 14 meters (46 feet) long and weighing 35 metric tons (38.5 short tons), to keep the smallest particles on their circular path at the LHC in Geneva. The facility

requires enormous cooling as well: down to minus 270 degrees centigrade (minus 454 degrees Fahrenheit)! Plus, the tiny particles should not collide with other ones during the acceleration phase, so a so-called ultra-high vacuum has been created inside the pipe. There's no air in it and practically no atoms either.

This complexity pays off, though. A particle accelerator like the LHC achieves extremes that are unique in the world: When the particles collide with each other they're traveling nearly at the speed of light. The smallest particles pass the 27-km (17-mi) tunnel 11,000 times

per second. When the ions crash into each other, they generate temperatures of over 4,000 billion degrees! That's about 300,000 times hotter than the center of the Sun. In the process, quarks and gluons "cook" to a kind of primeval plasma soup that takes the scientists as close as never before to the conditions prevailing at the time of the Big Bang.

But all this has to be measured as well. At the LHC, this is done by means of the ATLAS detector, a huge receptacle for atomic debris with a length of 45 meters (148 feet) and a width and height of 22 meters (72 feet). For the physicists, the detectors are a kind of high-performance camera taking more than 40 million pictures per second.

Particle accelerators like the LHC in Geneva or the DESY in Hamburg advance physics and our entire understanding of the world by producing new findings – about the behavior of the smallest particles or their existence in the first place. Scientists at CERN, for instance, in a one-billion-euro experiment, discovered a new elementary particle that was subsequently confirmed as the Higgs boson. The tiny particle that’s also referred to as the “God particle” has an extremely short life span of about 10 to 22 seconds, but, put in very simple terms – is responsible for particles having mass.

Chemists, material scientists and biologists use accelerators to create the brightest X-ray light in the world (see also info box on the right) in order to examine diverse materials, from aircraft turbines to vital proteins.

Deployed in medicine and manufacturing

However, only a few hundred of the more than 17,000 particle accelerators that exist around the world are used for scientific research. Another large field is medicine or, more precisely, radiation therapy. Smallest, extremely accelerated parts serve to specifically treat cancer as well. Somewhat smaller particle accelerators, so-called cyclotrons, are frequently used for this purpose. Here, in a spiral-like path, the electrons are accelerated also by means of magnets until they’ve finally achieved the desired speed. Cyclotrons often have a diameter of three to four meters (10 to 13 feet) which means that they can still be accommodated by hospital facilities. Some 7,000 particle accelerators are used for medical purposes worldwide to treat 30 million patients per year. The other systems are mainly found in manufacturing operations or, more precisely, in semiconductor production. The utilization of ion accelerators makes it possible to build fast transistors in chips which are

essentially used in all areas of digital electronics.

Meanwhile the scientists who are primarily focused on gaining new insights produce new knowledge from time to time. Last winter, for

instance, CERN scientists found out further details about the physical behavior of the Higgs bosons. And that’s just the beginning. The world of the smallest particles still holds an abundance of other great discoveries in store for us.

DESY AND THE FASTEST X-RAY IMAGES IN THE WORLD

5 million flashes per second can be fired by the new X-ray laser “European XFEL” (pictured) at Deutsches Elektronen-Synchrotron (DESY) – 40,000 times as many as the previous best pulse rate of an X-ray laser. For instance, the 3.4 kilometer (2.11 mile) long accelerator that shoots the world’s fastest serial X-ray images, made it possible to reveal the previously unknown structure of an antibiotics killer. Installed upstream of the X-ray laser is a 1.7-km (1.05-mi) – and thus the world’s longest – superconducting linear accelerator, a proprietary DESY development. In addition to particle physics and photon research, the development and construction of new particle accelerators is another focal area at DESY. The DESY tunnel system in Hamburg meanders underground all the way to the neighboring state of Schleswig-Holstein. DESY is part of the Helmholtz Association that Schaeffler cooperates with in research projects as well and, by its own account, ranks among the world’s leading accelerator centers. The LHC particle accelerator alone produces data volumes per year of a magnitude that could fill a million DVDs.



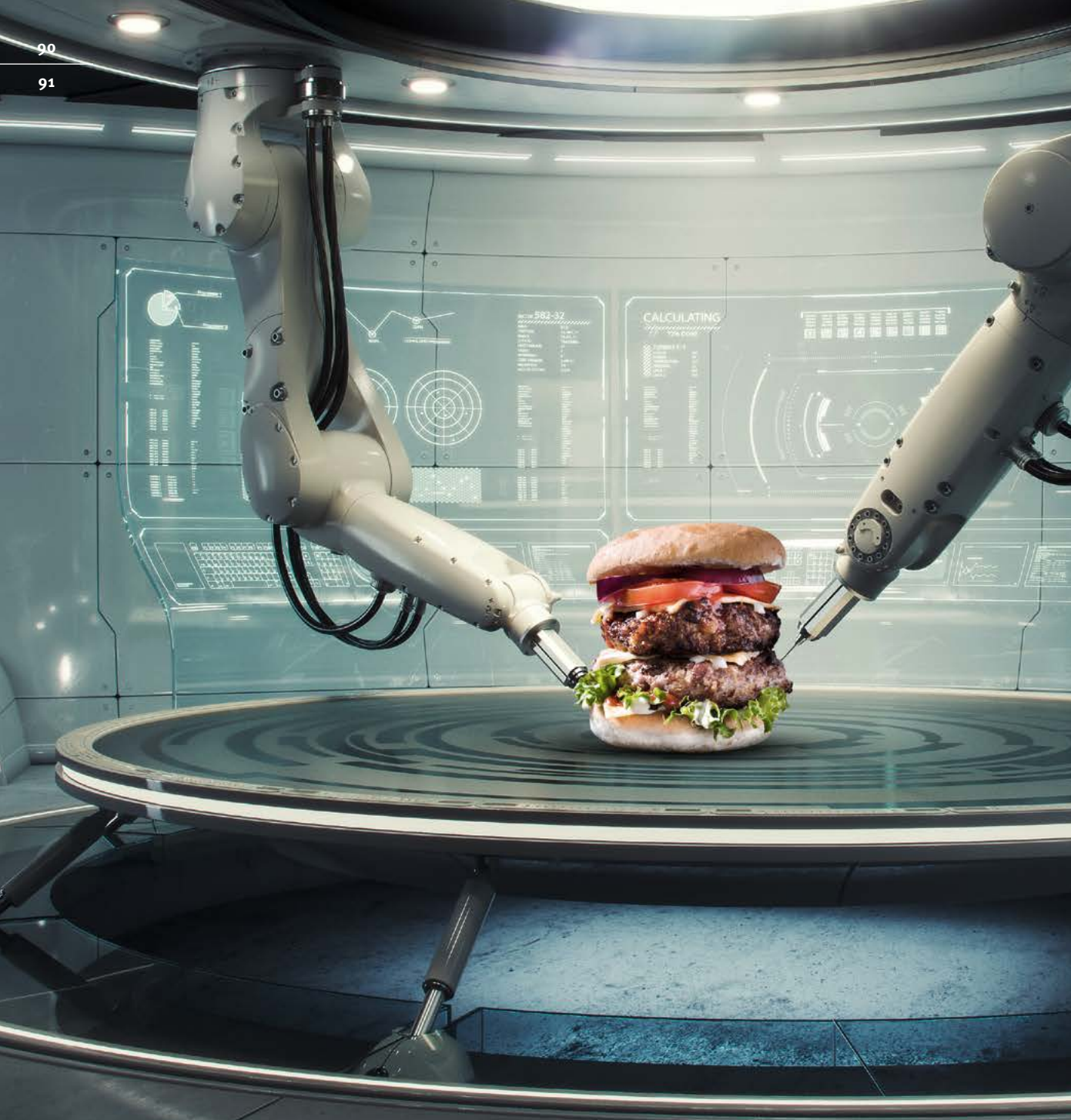

TURBO MEAT

— By 2050, the worldwide consumption of meat will increase by 85 percent, according to United Nations forecasts. To cover this demand while minimizing the adverse effects on animal welfare and the environment, scientists are developing cultured meat, in other words meat that's produced artificially. This is done by extracting muscle tissue from an animal to collect stem cells. Initially in a nutrient solution and subsequently in a bioreactor, these stem cells grow into muscle fibers in order to ultimately be processed as ground meat for burgers and sausages. The

benefits of cultured meat: It contains no toxins or other harmful substances and pathogens, plus it "grows" much faster. While beef cattle are ready for slaughter after 18 to 24 months lab-grown meat receives a turbo boost: Only six weeks following the extraction of the stem cells, it'll sizzle on the grill as a burger patty. The only thing still lacking for the product to be ready for the market is an acceptable price. While the first cultured-meat burger still cost 250,000 euros in 2013, it's supposed to be selling for only 8.50 euros at the time of market launch in 2021. —

outlook

Technology for tomorrow

» We shall escape the absurdity of growing a whole chicken in order to eat the breast or wing, by growing these parts separately under a suitable medium

Winston Churchill, 1931

RESOURCE CONSUMPTION IN MEAT PRODUCTION

in percent (beef = 100 %)

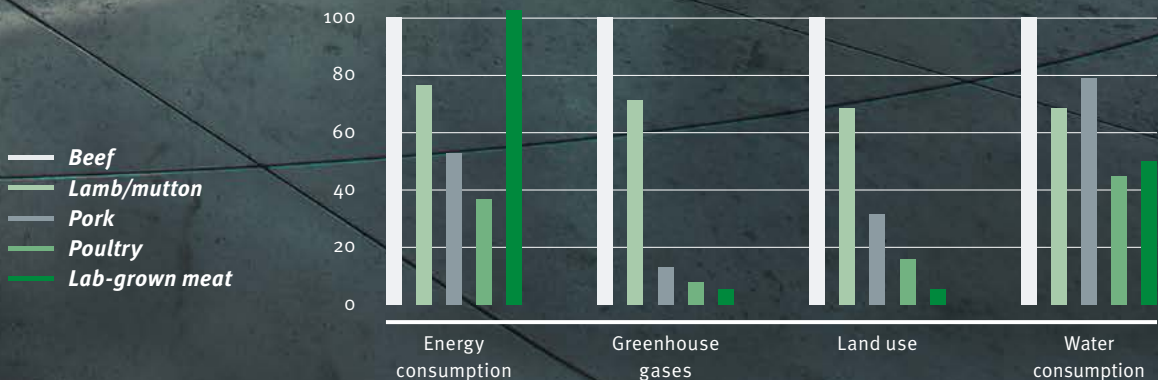

Source: Fleischatlas (Meat Atlas) 2018

THE END OF RANGE CONCERNS

Electric mobility is gaining ground on more and more roads, not least because of rapid progress being made in the development of high-performance batteries: ranges go up, charging times and prices down. Plus, new technologies are expected to even make everything a lot better.

— by *Andreas Burkert*

— Whether in New York, Rio or Tokyo – residents parking their cars at home again at the end of a workday will more than likely have traveled only short distances particularly in urban areas. If such commutes plus a safety buffer are used as the basis for developing the ideal electric vehicles for daily use the stored electrical energy of slightly more than 13 kWh would be sufficient, depending on the type of car and driving style. Current

electric vehicles like the BMW i3 would already be able to travel a distance of 100 kilometers (62 miles) on this amount of energy. That's enough for a few days of driving in and around cities.

If customers were satisfied with this type of range a lot of things in terms of electric mobility would already look a lot better now because the costs of traction



batteries and, consequently, normal electric vehicles would be a lot lower. For instance, at the current rate of 190 euros for one kilowatt hour (kWh) of electrical energy storage, a traction battery optimized for daily short-distance travel costs only 2,470 euros. That compares really well with the 10,000 euros consumers have to pay for the high-energy storage systems of current models. But, and this is a big “but”: Consumers expect battery-electric mobility to deliver the same advantages that IC engines do: spontaneously available and unlimited mobility. Even an empty fuel tank as a limiting element is refilled in practically no time at one of the countless fuel pumps spread across the country and, once filled, you’re on your way again. No electric vehicle provides this type of flexibility at the moment – not yet.

“Charging infrastructure as the greatest challenge”

At least progress in battery cell development has by now made it possible for vehicle developers to put medium-sized automobiles with a range far beyond 300 kilometers (186 miles) on the market. A prominent case in point is the Opel Ampera-e that thanks to a 60-kWh lithium-ion battery plus sophisticated range management covers about 400 kilometers (248 miles). The Hyundai Kona achieves similar distances and other automakers are upgrading their vehicles too, knowing full well that many consumers expect higher range as a prerequisite for choosing an electric vehicle.

German energy utility E.ON in a quest for precise information surveyed automotive customers across the country to find out what an electric vehicle would have to deliver in order to be purchased. According to

the results, concern about range appears to be the biggest obstacle. For 71 percent of the respondents, higher range is crucial for switching to an electric vehicle. In addition, the survey revealed, charging times were much too long and the number of charging stations was insufficient. Some 65 percent of the respondents criticized the current charging infrastructure. Dr. Jochen Schröder, President of Schaeffler’s E-Mobility Division, views the inadequate charging infrastructure as one of the greatest impediments to electric vehicle acceptance as well. “In the case of plug-in hybrids, this question is not quite as crucial, but the drivers of fully electric vehicles depend on a viable infrastructure. Many potential buyers of electric vehicles continue to be deprived of opportunities to charge their vehicles close to where they live – particularly in urban areas where electric cars offer the greatest advantages.”

However, Schaeffler’s electric mobility expert is not only concerned about the quantity and footprint of charging stations: “Charging times are currently too long as well. I feel that even 15 minutes for recharging will not be permanently accepted by all long-distance drivers because they’ve become accustomed to filling up on energy for a 500-kilometer (310-mile) distance in five minutes.”

Achieving such tank refueling equivalencies for electric mobility poses a huge challenge. One possible key to success: doubling the current standard voltage of a traction battery from 400 to 800 volts. Using this technology, Porsche together with Schaeffler clinched overall victory in the 24 Hours of Le Mans on three occasions. The findings gained with the 919 hybrid sports cars have been fed into the development of the future all-electric Taycan production model. The new peak current offers the major advantage that at a respective 800-volt DC charging column up to 350 kW can flow into the high-voltage battery. For comparison: Tesla’s superchargers currently achieve a maximum of 135 kW. However, even with 800-V turbocharging a Taycan has to be plugged in for about 20 minutes to draw electricity for 500 kilometers (310 miles), provided the driver finds a vacant charging column. To solve this problem, Porsche together with Audi, BMW, Daimler and Ford has joined the IONITY venture that pursues the aim of establishing 400 high-speed charging stations with up to 350 kW per charging point across Europe. That’s a solid plan for starters. Like Schaeffler’s expert Schröder, the EU sees a need for action as well and is funding the expansion of charging stations with 800 million euros. With that, the current number of 18,000 fast-charging points (>22 kW) could be clearly more than doubled,

70-70-scenario

Of 117 million vehicles under six tons (13,228 lbs.) of the annual production in 2030 40% will be using hybrid powertrains and 30% each ICE or electric powertrains. **This means that 70% will still have an IC engine and 70% an electric powertrain.**

Source: IHS and Schaeffler

More than 260

new battery-electric automobile models are planned to hit the market by 2024.



UNDER 2 MIN.

This is how long the fully automatic battery change is supposed to take at charging stations which the Chinese electric carmaker NIO is planning to establish initially along domestic freeways. 1,100 of them are planned by 2020. Battery changes within minutes are another possibility to relieve “petrol heads” of their concern with range. Will it be successful this time? In 2008, Better Place launched a similar idea in Israel and Denmark but failed – not least because customers weren’t willing to pay the higher price of switching to electric vehicles.

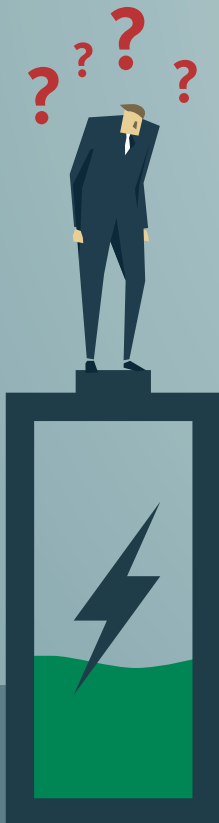

according to the European Alternative Fuels Observatory. Legislative pressure (e.g. mandatory charging stations at office and commercial facilities and apartment buildings) is intended to accelerate the spreading of plug-in places as well.

Mass-producible cells as a key to affordable electric mobility

A factor that plays a less decisive role with the typical Taycan clientele but definitely does in the high-volume market is the purchase price. That the price for an electric vehicle with a minimum range of 500 kilometers (310 miles) is still higher than that of a comparable vehicle with an internal combustion engine for instance irks 73 percent of German automotive customers, according to the E.ON survey. However, exactly this reservation about switching to electric mobility has been keeping the prices high because if battery cells could be produced in larger quantities the costs per unit would drop as well. Automotive OEMs are hoping that the predictions of some experts will come true. According to such forecasts, prices compared to those today are expected to decrease by nearly 50 percent – to 108 euros per kilowatt hour. This can, not least, be credited to established battery producers such as Northvolt, LG Chem and Samsung SDI that primarily reside in Asia but have begun to venture into Europe to ramp up production there as well. Consequently, the supply of battery cells is likely to be assured for the anticipated growth of the electric vehicle market.

The post-lithium-ion era

However, is the lithium-ion battery the gold standard? At the moment and for the medium run, such generation 2 and 3 traction batteries are planned for deployment in electric mobility, but there are alternatives that score with considerably higher energy density. They include the lithium-sulfur battery that may be utilized for vehicle applications after 2020. The capacity of such a lithium-sulfur battery is three to five times as high as that of its lithium-ion relative, plus it’s less costly to produce. There’s a hitch in the technology that still has to be overcome, though: Sulfur has a latent tendency to become unstable during the charging process. However, in April, scientists at the University of Texas at Dallas announced that they achieved a breakthrough in the development of lithium-sulfur batteries that massively extends the life of the electricity accumulators due to the use of molybdenum.

SCHAEFFLER COLLABORATES IN **LARGE-SCALE ELECTRIC STORAGE TECHNOLOGY**

Intermediate storage of renewable energies, peak load balancing in industrial operations or charging infrastructure for electric mobility: Large-scale stationary energy storage systems are becoming increasingly important. In order to drive their industrialization, Schaeffler will be collaborating with specialist CMBlu in the future. An attractive aspect: the new “organic flow” storage technology does not use rare earths and heavy metals.

In the past five years, CMBlu together with research groups from German universities developed the “organic flow” renewable storage technology for power grids to prototype level. Based on this, Schaeffler and CMBlu are planning to jointly develop commercial products. The underlying functional principle resembles that of conventional redox flow batteries. The electrical energy is stored in chemical compounds and the reaction partners are avail-

able in an aqueous form as electrolytes. In contrast to conventional, metal-based systems, organic flow batteries use organic molecules from lignin for storage. As a component of plants lignin is a naturally renewable material and in pulp and paper production for instance is generated as a waste product on the scale of millions of tons. All electrical engineering components in the energy transformer were adapted to these electrolytes and designed for cost-efficient mass production. The near-complete value chain for

the batteries can be covered locally without imports. In addition, the storage devices are not only free from rare earths and heavy metals but not flammable either and so can be operated very safely. Due to its functional principle, the capacity of an organic flow system can be scaled irrespective of its electrical output and is only limited by the size of the tanks and amount of electrolytes.

The first commercial systems are planned to be launched starting in 2021.



Schaeffler is setting high hopes on the lithium-air battery as well. This close relative of the classic fuel cell, though, based on current knowledge, will not be ready for the market before 2030, according to Schaeffler’s Chief Technology Officer Prof. Peter Gutzmer. The massive storage device is supposed to have 20 times higher specific energy than conventional lithium-ion batteries. With a lithium-air battery weighing only 60 kilograms (132 lbs.) a vehicle would be able to travel a distance of up to 500 kilometers (310 miles). The Tesla S battery weighs ten times as much. Scientists are still facing a number of hurdles such as inter- or deposits and oxidation that reduce output and life. A potential intermediate step toward the lithium-air battery is the iron-air version that’s slightly easier to

implement. It would still offer two to four times the energy density of a lithium-ion accumulator, according to predictions. Oak Ridge National Laboratory in the United States and the German Research Center Jülich are regarded as particular drivers of this technology. But even they themselves say that it’s still a long journey until the technology will be ready for the market. Although iron electrodes in isolated laboratory trials can already be operated for several thousand cycles without major performance losses full-fledged iron-air batteries using an air electrode as an anti-pole have only lasted for 20 to 30 cycles to date.

So the end of range concern is not yet completely within range.



SIT BACK RELAX!

Working, making phone calls, sending emails on the road: Autonomous cars will accelerate our lives and increase our productivity – or we'll just let them treat us to a break for a couple of hours.

— by Marcus Efler

— In a town north of Munich, Germany, sound engineers are experimenting with tomorrow's listening pleasure. From large speaker boxes a couple of bars of a symphony can be heard but in the sound-proofed room, they come across dry and sterile. An employee clicks a key on his laptop and suddenly the sound widens, the listeners feel like they're sitting in a large concert hall. A little later, listening to a piece of heavy metal gives them the illusion of being part of the audience at an open-air concert and then another click of being on stage right with the band.

What audio systems specialist Harman develops here is supposed to revolutionize the listening experience in automobiles – coming soon and at the latest when autonomous vehicles begin to rule our roads. When none of the occupants have to concentrate on traffic anymore and everyone has time to sit back and



relax: for instance while listening to sophisticated music such as classical or jazz or to the soundtrack of a movie running on a large screen. Even the acoustical simulation of a movie theater will soon be technically feasible.

The equipment that's already installed in today's modern cars helps create the illusion: surround speakers plus the microphones of the speaker phones that recognize sound reflections and high-performance electronics whose algorithms convert files in real time and – by the way – restore the sound quality MP3 files may have lost.

Multifunctional space

The car as a concert hall – a symbol of the fundamental transformation this invention from the century before last is currently experiencing. Its original purpose of overcoming distances is complemented by another one that in the future will be no less

important: autonomous motor vehicles will morph into a lounge, office and break room. “Your self-driving car can become anything for you,” promises Johann Jungwirth, one of the digital masterminds in the automotive industry: “A concert hall, a movie theater, an art museum, a sports arena, an augmented reality room, a conference room, a massage practice and much more.” For the former Mercedes, Apple and current VW developer, besides safety and personal mobility for everyone, the gain in time is one of the key benefits of self-driving vehicles. “Every user of an automobile spends an average of 37,668 hours of their life in it,” he explains, “Just imagine all the things you could do during this time!”

So, what kinds of things might that be? You could, for example, relax, decelerate, chill out, in other words deliberately enjoy the time as free time – like even executives do now and then on long-haul flights. Not everybody spends their entire time above the clouds busily tapping the keys on their laptop. Watching videos, listening to music or gaming are all part of airborne relaxation.

NEW DIGITAL BUSINESS MODELS IN THE AUTOMOTIVE INDUSTRY

Annual sales forecast for 2030 in billion euros

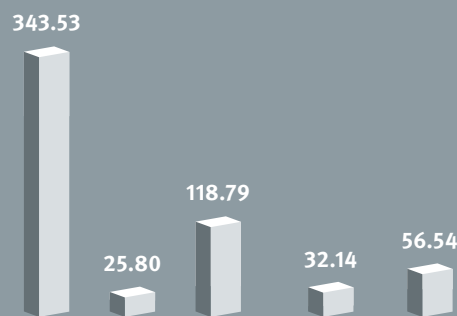

Shared Economy/Mobility on Demand
(B2C car sharing, P2P car sharing, intermodal travel platform)

Automated driving

Connected car
(Services centered on connected cars, mobility app platform)

Living brands
(Eco-system for digital mobility offerings, such as infotainment or hotel reservations)

Data monetization
(Monetization of vehicle and user data)

Source: a study by Accenture Strategy



Easygoing business meeting at 120 km/h (75 mph) – just one of many possible use cases Volvo envisions for its self-driving “360c” concept

The really big advantage of traveling 10,000 meters or 33,000 feet above the ground: Although more and more carriers are now offering WLAN service there as well nobody’s expected to be permanently reachable on an airplane (yet).

Exactly this is what’s expected though when traveling by car. There’s no reason why someone sitting behind the wheel shouldn’t be able to make phone calls. If they don’t even have to touch the phone they should actually be a lot more productive: the autonomous car as an accelerator of life. The self-driving function as an electronic chauffeur while the boss is working; what has been a privilege of a select few will soon become a standard for everyone.

Around the world, developers, engineers, digital experts and designers are thinking about what such a driverless multifunctional space could look like. Take Volvo for example: a steering wheel, pedals, cockpit controls – the viewer looks for all these things in vain in

the recently unveiled “360c” concept. Superfluous, say the Swedes, when the driver turns into a passenger. Instead, two large wing doors provide access to an amply glazed compartment. It can either be furnished as a stylish lounge, multifunctional office or comfortable sleeper including a bathroom sink – depending on what the traveler has ordered by means of an app. A whole array of digital gadgets is a must anyway. If desired, even lunch for a business meeting, popcorn for the evening movie or other services can be ordered as well. 2030 is the target year for making this reality.

Road travel similar to trains and planes

Other manufacturers are presenting similar concepts – such as Audi’s “Aicon.” Here, as well, the interior resembles a first-class suite in which huge screens are installed but no steering wheel or pedals. “You don’t necessarily have to own such a vehicle yourself,” says Audi’s chief designer Marc Lichte. “You use it for your



AS IF BY MAGIC

The SPACE DRIVE “drive-by-wire” system uses **electrical impulses** for steering, braking and accelerating – an important basis for automated driving

THE **BACKBONE** OF AUTOMATED DRIVING

A pedestrian sees a red light. Sensors (in this case the eyes) receive the light signal. This information is forwarded to a control center with a high-performance computer (the brain) where it's processed: red light = stop on the spot. However, for the command to be executed, it has to reach the actuator (in this case, the leg muscles). This is the job of the motor nervous system.

Without this “data highway” of the body motion would be impossible. **When applied to automated driving, such a motor nervous system is referred to as “drive-by-wire” technology.** Accelerating, braking, steering – all this is no longer accomplished via a mechanical or hydraulic

connection but by electrical impulses. **The SPACE DRIVE solution with triple redundancy is the world's only “drive-by-wire” system with global approval** and in addition – installed in automobiles for people with physical disabilities – has a track record of 700 million accident-free kilometers (435 million miles). Paravan has contributed SPACE DRIVE as a key technology to a joint venture in which Schaeffler holds a 90-percent stake. Paravan's founder Roland Arnold is the CEO of the new Schaeffler Paravan Technologie GmbH & Co. KG.

The Schaeffler Mover, which the Schaeffler Group contributes to the business, plays a special part in this new joint venture. The small and very

agile vehicle concept is fully electric and – featuring various body styles – can be flexibly used for diverse transportation needs in urban areas. **“With the Schaeffler Mover as a development platform we demonstrate our claim of becoming an innovative partner in the field of mechatronic chassis systems** and continuing to develop this role through to the ‘Rolling Chassis’ where we plan to position ourselves as one of the market leaders in the medium run. Even entire vehicle platforms for logistics and service companies are conceivable in the future,” says Dr.-Ing. Dirk Kesselgruber, who heads Schaeffler's chassis business and is a member of the management board of the young joint venture.

specific purpose,” for instance, for inter-city hopping on the freeway in a luxurious ambience: an offer that’s also intended to compete with trains and airliners – custom-configurable and with utmost privacy.

Aprilli Design Studio in Toronto is even planning to put an entire hotel suite on a self-driving chassis – including a bathroom. The award-winning concept (“Radical Innovation Award 2018”) might become a mobile link between different hotels. As a result, guests would always wake up in the same room but in different hotels at different locations: cruises for the road with a travel distance of some 1,300 kilometers (800 miles) in 12 hours.

There’s a lot of money to be made

The autonomous car, according to the current vision, is closely linked to car sharing – or ride sharing. In the city for instance, instead of using fast freeway express vehicles, it would be more practical to switch to swift and agile urban ones such as the Schaeffler Mover (see also left-hand page) which in the “People” version is a kind of self-driving share taxi. A ride in such an autonomous mini bus might even be free – if the passengers agree to be exposed to commercial advertising.

So that takes us to the topic of the monetization of services offered in conjunction with autonomous vehicles. The fact that the traditional automakers for a long time balked at adopting “Apple Car Play” and “Android Auto,” in other words the many onboard functions enabled by smartphones and their operating system, has to do with exactly this question: Who will gain control of entertainment, communication, information and navigation? The question is a crucial one because the party that does will determine (or at least know) what activities the occupants of an autonomous automobile engage in on the road. And will be able to influence them – or the car – accordingly. Green light for new business models: Digital mastermind Jungwirth for instance can imagine a so-called freemium model for autonomous cars. VW’s “Sedric” concept that he thought up would – according to one of Jungwirth’s scenarios – chauffeur people who

»» *Like switching from the horse to the car*

Digital mastermind
Johann Jungwirth
about the significance
of self-driving cars

want to go shopping automatically and for free to a supermarket that would show commercials of its products to them on the way there. “However, people paying for their ride would obviously have the choice of where the vehicle would take them.” Plus, of what they’d listen to and watch on board.

The opportunities, however, that autonomous automobiles offer are simply too enticing. People passing by a restaurant would have the menu of the day projected onto the windows. Someone who recently watched a movie starring a particular actor would be alerted to that actor’s latest film while passing by a movie theater. Essentially, the vehicle occupants would not even have to be able to look out the windows. Instead, where glass windows are still found today, they’d see promotional messages. Pleasant prospects of a new world?

Perhaps a more pleasant one would be to keep one’s eyes closed – and to turn on the virtual concert hall.



Hotel rooms on wheels: the self-driving “Aprilli Travel Suite”



THE AUTHOR

Marcus Efler, a graduate of the Axel Springer School of Journalism, was in charge of the automobile desk of the German news magazine “Focus” for many years. Today, he’s deputy editor-in-chief of the car and travel magazines “Cabriolife” and “Fat Mobility Report.” In addition, as a writer, he covers automobile/motorcycle, new mobility, travel and consumer electronics topics.

BATTLE



BETWEEN BRAINS



In the future, artificial intelligence will not only beat us in board games. In medicine, in commerce, at home or in traffic scenarios – AI is on a fast track practically anywhere. Its triumph seems unstoppable. But will circuits really become smarter than humans?

— by *Denis Dilba*

— In 27 years from now artificial intelligence will have surpassed human intelligence for the first time. At least that's what Ray Kurzweil predicts. Since the early 2000s, the American, a writer, futurist and Google's Director of Engineering, has been thinking about the effects of artificial intelligence on society, among other things. Kurzweil believes that from 2045 on, when computers are becoming smarter than humans, the so-called technological singularity will arrive. At that point, machines will self-improve faster and faster by means of artificial intelligence, causing technological progress to explode in all areas. This transformation will be so rapid and all-encompassing that the subsequent future of humanity will be hard to imagine. While Kurzweil, an optimist, assumes that we'll all become immortal due to the fusion of humans and machines, philosopher Nick Bostrom fears the demise of humanity: machines will no longer need us.

How much intelligence is possible?

Even though Kurzweil and Bostrom are to be taken seriously many other scientists have serious doubts

that the singularity resulting in machines passing us in the fast lane will happen: Many prominent people who feel that way are not working directly in the field of artificial intelligence, says Toby Walsh from the University of New South Wales in Sydney, one of the leading experts in AI research. “Most people working in AI like myself have a healthy skepticism for the idea of the singularity. We know how hard it is to get even a little intelligence into a machine, let alone to achieve recursive self-improvement,” writes Walsh in an op-ed article for the U.S. magazine “Wired.” There are many technical reasons why the singularity might never happen, he says. “We might simply run into some fundamental limits.” Walsh, for example, thinks that it’s possible that there are limits to how smart you can be, similar to the speed of light limiting acceleration.

Wolfgang Wahlster does not believe that machines will soon be smarter than we are either. “Both in hardware and software there are such massive differences between a current AI system and the human brain that AI is still an extremely far cry from the brain’s capabilities and practical intelligence,” says the head of the German Research Center for Artificial Intelligence (DFKI) headquartered in Saarbrücken, so nobody needs to fear the Terminator. However, that does not at all mean that AI technology necessarily produces worse results than a human being in all areas, according to the AI expert. The dominant victories achieved by AlphaGo, an AI system of Google’s subsidiary DeepMind, demonstrated this last year: The Chinese Ke Jie, then the number one in the Go world ranking, had no chance. Plus, machines are now outperforming us in chess, checkers, Scrabble and company as well as in other activities previously reserved to humans and their cognitive abilities.

“Algorithms are in the background of all processes”

They include image and speech recognition as well as automatically capturing information from texts or checking sensor data for the presence of specific patterns. “Even today smart maintenance programs based on AI algorithms are already able to tell from such readings when an industrial system needs to be serviced so that damage is prevented in the first place, says Jürgen Henn, who is responsible for Strategic IT at Schaeffler. “The machine then automatically orders the required spare parts and a service technician – scheduled at a

time when the machine’s workload is lower than usual so that economic losses are minimized.” But that, says the Schaeffler expert, is just one of many examples. AI not only increases the availability of machines. “Ultimately, such algorithms in the background of all processes, from the supply chain to production control through to the pre-selection of job applicants, will enhance efficiency,” says Henn. “We’ve already implemented initial AI applications, and there will be more.”

16

terabytes of random access memory are available to IBM’s AI Watson – **2,000 times more** than to a standard laptop with an 8-gigabyte RAM.

Source: IBM

The number of AI applications is not only growing at Schaeffler. About a year ago, Katja Grace from the Future of Humanity Institute at Oxford University interviewed 352 of the world’s leading AI scientists to find out when smart machines will surpass us in certain activities. Some of the results were to be expected. For instance, AI systems will surpass humans in the next ten years in translation (by 2024), writing essays for high school (2026) and driving trucks (2027), according to the experts. With other tasks, though, Grace’s survey shows that a lot more time will pass before this happens than expected. In spite

of Amazon and its new “Go” stores without cash registers, there’ll be no getting around human employees in retail before 2031. That will also be the year in which machines will start to be able to write bestsellers. They’ll only be able to become surgeons from 2053 on.

Humans in front thanks to versatility

Starting in 2062, says the forecast, AI will be better than humans in practically any individual activity. However, for one, predictions made so far in advance always have to be taken with a grain of salt, especially since the experts queried have already proven to be fallible: They predicted that an AI would only be able to beat humans in the strategy game Go in 2027 – whereas it actually happened while the survey was still being analyzed. On the other hand, the statement that AI systems are better than humans in all activities does not at all mean that there’ll be a single system combining all these abilities and that will then be as intelligent as human beings. While humans at that time will no longer be able to keep pace with an AI in all areas it does seem that on the whole the ability to do all things “pretty well” will still be adequate to secure humans the top spot in the race between them and the machine.

MILESTONES IN AI RESEARCH

1950 TURING TEST

British math genius Alan Turing develops a method to test **whether a computer is able to exhibit intelligent behavior**. The Turing test is still in use today.

1951 FIRST NEUROCOMPUTER

The first neurocomputer designed by American mathematician and AI pioneer Marvin Minsky has **only 40 neurons**. The computer was used to simulate the behavior of laboratory rats.

1956 THE TERM “ARTIFICIAL INTELLIGENCE” IS COINED

In an application for an academic conference at Dartmouth College in Hanover (USA) **computer scientist John McCarthy** uses the term “artificial intelligence” for the first time.

1960 FIRST COMPUTER WITH AN ABILITY TO LEARN

American psychologist and computer scientist Frank Rosenblatt designs a computer with an ability to learn according to trial and error that lays the **foundation for neuronal networks**.

1966 FIRST CHATBOT

Joseph Weizenbaum, a German-American computer scientist, develops the **computer program Eliza**. It pretends to be a psychotherapist and mainly responds with questions and phrases.

1979 BACKGAMMON PROGRAM WINS AGAINST WORLD CHAMPION

Backgammon software programmed by German-American computer scientist Hans Berliner beats a human world champion for the first time: Luigi Villa from Italy.

1997 COMPUTER BECOMES WORLD CHESS CHAMPION

Russian world chess champion Garri Kasparov is defeated by IBM's program **Deep Blue** checkmating him under tournament conditions. A year before, Kasparov had still won the duel.

2011 AI WINS AT A QUIZ SHOW

On the American TV show “Jeopardy!” **IBM's AI Watson** is pitted against two quiz champions who had previously won record sums – and doesn't give the human competition the slightest chance.

2011 SPEECH ASSISTANT SIRI DEBUTS

On October 4, 2011, Siri is introduced to the world. Apple's speech recognition is not only able to process individual words but even **whole sentences and questions**. Today, Siri understands more than 20 languages.

2016 NEURAL NETWORK AS A SCREENWRITER

Programmed by the American Ross Goodwin, the AI bot Jetson that later calls itself Benjamin **writes the screenplay** for the short film “Sunspring” and composes the soundtrack for it as well.

2017 ALPHAGO BECOMES UNBEATABLE

The AI system of Google's subsidiary DeepMind becomes so powerful that the **number one in the Go world ranking** is unable to fight back and loses 3–0.



NEED FOR

The future of travel holds great promise: We are going to move in cleaner, more efficient and, above all, faster ways from A to B than ever before – on land, in the air and on water.

— by *Oliver Jesgulke*

— For thousands of years, humans have been striving to move forward faster and faster. Like the urge to make buildings rise higher and higher into the sky and to explore the depths of outer space, speed has always been an engine and a symbol of progress. The near-obsessive fixation of scientists and adrenaline junkies on speed has led to a number of record-breaking attempts in the past 120 years. On April 29, 1899, the Belgian engineer and race driver Camille Jenatzy in his electric car “La Jamais Contente” achieved a top speed of more than 100 km/h (62 mph). About 70 years later, the American Gary Gabelich broke the the 1,000-km/h (6,200-mph) mark in his rocket-powered vehicle “The Blue Flame.” On October 15, 1997, Royal Air Force Wing Commander Andy Green set the world speed record of 1,227.985 km/h (763 mph) in the jet-propelled “Thrust SuperSonic Car” in the Nevada desert as the first human to break the sound barrier in an “automobile.” Now, in the form of the “Bloodhound SSC,” the next hybrid – of a Eurojet engine from the Eurofighter and a sort of Formula One race car s pursuing a new thrilling speed experience. It’s shooting for 1,600 km/h (1,000 mph). These horsepower behemoths have one thing in common: they’re totally unsuitable for travel.

Hyperspeed by Hyperloop

The Swedish road-approved Koenigsegg Agera RS supercar achieves a remarkable 447 km/h (278 mph). But land travel can be even much faster, more eco-friendly and, above all, cheaper. The new Lo model range of the Japanese Shinkansen supertrain broke the 600-km/h

(373 mph) mark in tests and so atomized the records set by its competitors, TGV, Velaro, ICE and Transrapid Shanghai. Plus, the train of the future may even achieve supersonic speed in the years ahead: Silicon Valley’s enfant terrible, multi-entrepreneur Elon Musk, put forth the idea of people soon traveling in pods through vacuum tubes at speeds of up to 1,200 km/h (750 mph) – like in a type of tube mail. At the moment, the startup ventures Hyperloop Transportation Technologies, Tripod, Virgin Hyperloop One and Arrivo – The Arrival Company are fighting a head-to-head battle to find favor with investors and to build initial test routes.

In a Hyperloop, we would travel faster than on a commercial aircraft unless we boarded one of those

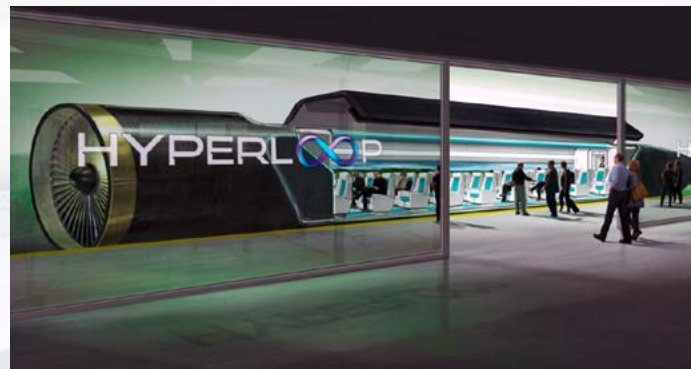

Faster than a jet aircraft: the Hyperloop train is supposed to shoot through vacuum tubes at 1,200 km/h (750 mph)

SPEED

supersonic planes that finally put an end to grueling long hauls. When it comes to supersonic aircraft, the situation is a little like it used to be with traveling to the Moon: we had already reached that stage many years ago.

An image like a thunderbolt

It was the reason why top executives and celebrities would leave their private jets in their hangars: Concorde. The jet, a British-French co-production with conspicuous delta wings and a nose that could be lowered for take-offs and landings achieving twice the speed of sound (Mach 2) of up to 2,400 km/h (1,500 mph) soon evolved into the world's fastest commercial aircraft. With that, the "queen of the skies" flew on a par with fighter jets of the Russian MiG model range, the Tornado or the F-14 from the movie "Top Gun." In any event, the airliner with its four engines and afterburners gave passengers the feeling of sitting in such a jet fighter – at least until the champagne and multi-course menus were served. Instead of seven, Concorde only needed three hours for the non-stop flight from New York to London. A ticket was so expensive that in the age of mass air travel the Concorde lounge was regarded as the last oasis of exclusivity. However, the prestigious airliner was never profitable: Concorde's purchasing price and maintenance costs were twice as high as those of a Boeing 747 and per hour of flight it burned four times the amount of kerosene of a jumbo jet that offered far more seats. The disastrous financial performance of Concorde operation, the noise caused by the supersonic boom and, last but not least, the crash of Concorde 4590 on July 25, 2000



In 20 to 30 years from now, Boeing plans to cover the distance between London and New York with a hypersonic jet:
Vmax: 6,000 km/h (3,730 mph)



DIVING INTO SUPERSONIC SPEED IN A SUBMARINE

While the pace on land and in the air is getting faster and faster, it seems that by comparison progress on and under water is only being made at a snail's pace. As early as on its maiden voyage on July 3, 1952, the "United States" ocean liner won the Blue Riband for the fastest Atlantic crossing within 3 days, 10 hours and 40 minutes. This record – at least with ships of a comparable size – has been unbroken to date. Even so, there are exceptions: At 275 knots (511 km/h / 318 mph) Ken Warby sped across an Australian man-made lake in his jet-propelled motorboat "Spirit of Australia" on October 8, 1978. But what about marine travel at supersonic speed? For submarines, supercavitation provides an initial approach: As soon as a boat is surrounded by a protective bubble, its resistance against water decreases. Theoretically, the sound barrier could be broken in this way under water which, converted to ground speed, would make the boat 5,800 km/h (3,600 mph) fast. As a result, the Atlantic could be crossed in less than one hour.



that cost 113 lives for the time being marked the end of commercial supersonic air travel.

The resurrection of supersonic travel

As the Concorde era ended, supersonic flight again became a traveler's dream – and one that might become true again. Fifteen years after Concorde's last flight, several projects around the globe are dedicated to this challenge. NASA and global aerospace, defense, security and advanced technologies corporation Lockheed Martin are working on a 1.2 Mach supersonic plane. Whereas Concorde used to wake up entire villages located in the approach patterns, the "X-Plane" only reaches 75 decibels when breaking the sound barrier, which is not much louder than the sound of shutting a car door. The wide-spread bans of supersonic aircraft in air space for noise abatement reasons is to be circumvented in this way, particularly as most long-haul routes are flown over land.

In spite of these obstacles, the doers at startup Boom Technology are aiming to make their supersonic aircraft even faster. The 3D animations of the three-engine Boom Airliner are highly reminiscent of the Concorde's silhouette. The airliner for 55 passengers is planned to shuttle passengers at a speed of Mach 2.0, for instance between Sydney and Los Angeles, starting as early as in 2023. Boom Technology is currently working on a smaller, flyable demo version named XB-1 in order to test aerodynamics, the carbon fiber composite materials used on it and the engines.

Supersonic speed is out, hypersonic speed is in

However, supersonic travel has long been surpassed by the new trend of hypersonic speed. As early as in 2004, NASA conducted several test flights with the unmanned X-43A aircraft that was lifted to an altitude



of 13 kilometers (8.07 miles) by a B-52 and then disengaged from it. It achieved a speed of Mach 9.6, around 10,600 km/h (6,587 mph). With the “Hypersonic International Flight Research Experimentation” program (HIFIRE) – an international team of scientists and members of the military from 2007 to 2017 conducted research into further fundamentals of hypersonic flight. In summer 2018, U.S. aircraft maker Boeing added a concept for a hypersonic passenger jet. The aircraft is supposed to achieve a top speed of more than 6,000 km/h (3,700 mph). This corresponds to five times the speed of sound, in other words Mach 5. As a result, the distance from London to New York could be traveled in one hour.

To this end, Boeing uses a novel type of engine design that combines the elements of a turbine and those of an athodyd. The European Space Agency (ESA) on the other hand in the form of “SABRE” invests in a novel hybrid of a jet and rocket engine for hypersonic speed that is supposed to use hydrogen instead of kerosene as fuel. However, 20 to 30 years will still pass before that’s the case. Much earlier, in 2019, affluent passengers will be able to take an excursion into outer space close to the Earth. That’s what the companies offering this opportunity, Blue Origin and Virgin Galactic, promise with their space launchers.

“Beam me up, Scotty”

If the primary principle of land, air and sea travel is to haul people from A to B faster and faster wouldn’t the final goal be to travel without any time delay? In science fiction movies, video games and fantasy books, the idea has long been part of standard equipment. Faster automobiles and breakthrough hypersonic jets entail their specific risks. These, however, are insignificant compared to the risks of teleporting a living being that also raises ethical questions: the dissolution of a body and a conscious mind and its reassembly at a different location. In physics, instantaneous “beaming” from A to B

by means of quantum technology actually works – for specific properties like those of light particles or atoms. However, objects or even living beings cannot be teleported this way. The alternative idea of transmitting a person digitally and to physically reassemble that person at a desired position fails because it is technically unfeasible. The University of Leicester has performed an example calculation: It would take 26 tredecillion (42 zeros) bits of data to teleport a grown human being – an unimaginable data volume that would take several trillion years to transmit even with a bandwidth of 30 GHz.

Theoretically possible as well – as calculated by the Mexican physicist Miguel Alcubierre as early as in 1994 – is traveling at the speed of light or even at faster-than-light speed that’s frequently practiced in sci-fi movies. However, making it reality would require a spacetime warp (which gave the warp drive in Star Trek and other sci-fi works its name), a kind of bubble surrounding the vehicle. Creating it, says Alcubierre, would require the amount of energy stored in the entire mass of planet Jupiter. Scientists up to and including NASA physicist Harold White are pursuing the idea in order to enable such targeted manipulation of spacetime in a very distant future.

However, until that time has come, it’s best to simply start walking – or to wait for the next hypersonic aircraft.



THE AUTHOR

Oliver Jesgulke once broke the 280-km/h (174 mph) mark as his personal top speed on the autobahn. Mach 2 is a dimension he’s only familiar with from stories told by his father who was a German Air Force fighter pilot and even survived the crash of an F-104 “Starfighter.”



A LATE BUT POWERFUL REVOLUTION

First described 35 years ago, 3D printing is a step-by-step game changer in manufacturing technology. Schaeffler's Additive Manufacturing department knows what kinds of things already work with additive technology today and what will only work tomorrow or not at all.

— by Denis Dilba

— Nearly all of us at one time or another heard that 3D printing will change industrial manufacturing in major ways. However, only a look at the past gives any indication of how big the changes will really be: Even the ancient Egyptians used to cut sand stone from mountains by means of simple ropes. Although today's wire saws use diamond-plated or steel wire and are powered by motors, the principle has remained the same for more than 2,000 years. Be it a hemp rope or a high-tech saw: Both remove material, and so do drilling, milling, planing or grinding. For centuries, these cutting and machining technologies have been removing wood and metal and, more recently, plastics or ceramics as well, and so enable the creation of defined components. 3D printing operates in a totally different way, as Carsten Merklein, the head of Schaeffler's Additive Manufacturing department, explains: "We no longer remove material to produce something – we simply add it and in this way cause things to directly materialize from powders, pastes or liquids. This simply did not exist before," says the expert. But that's not the only reason why Merklein regards 3D printing as the biggest manufacturing technology leap in the past 200 years. "Unlike in machining, where a lot of excess material is lost, only the amount of material required to produce something is applied in 3D printing. This saves resources." Arguably the biggest advantage in Merklein's view, though, is this: "No matter whether it's machining, casting, deep drawing or even CNC-milling – there's no other manufacturing technology that makes it possible to transfer digital designs so directly into the material world as 3D printing."

Merklein is by far not the only one to hold this view. Prominent support, among others, includes that of Barack Obama who in a state of the union address in 2013 said, "3D printing has the potential to revolutionize the way we make almost everything." Former U.S. Vice President Al Gore in his book "The Future" even compares the new manufacturing technology with the introduction of the assembly line in the automotive industry by Henry Ford at the beginning of the past century. And 3D printing pioneer Neil Gershenfeld, a professor at the Massachusetts Institute of Technology, even expresses a more emphatic assessment by predicting that 3D printing will not only redefine power structures in



» **Components can and must be designed in completely different ways for 3D printing**

Carsten Merklein, Schaeffler Additive Manufacturing

industrial manufacturing but disrupt the business world as a whole. However, the enormous potential of 3D printing will be anything but easy to tap, as Schaeffler's specialist Merklein explains: "Components can and must be designed in completely different ways for 3D printing – this presupposes a totally new type of thinking."

3D printing is not always cost-efficient

For this reason, Schaeffler and many other companies have long begun to explore the manufacturing principle that was first described by the Japanese scientist Hideo Kodama as early as in 1981. "We introduced additive technology in the late 1990s, at first exclusively for rapid prototyping and since 2012 for producing functional components as well," says Merklein. Subsequently, the growing importance of 3D printing motivated Schaeffler to make further investments in the technology: In 2015, an "Additive Manufacturing Fab Shop" was established. "That's a hybrid of a so-called FabLab for experimentation and a shop floor for production," explains the expert. One of the objectives pursued by his team of currently nine members is to drive additive manufacturing of smart tools and functional prototypes using 3D printing for customer applications, says Merklein. "On the other hand, we're already systematically investigating opportunities for additive technology to make positive contributions to our production system."

Colleagues from other departments who have heard about this topic regularly visit Merklein's fab shop kingdom to ask if a specific part can also be 3D-printed. "Typically, these are still components that have been designed for conventional manufacturing," says Schaeffler's additive manufacturing expert. In that case, he and his team investigate to what extent a 3D printing-friendly design is possible so that the benefits of the new technology can be used.

"In many cases, this is possible but in others it's not," says Merklein. "As a rule of thumb we can say



For this tool base frame of a press, two columns were "printed" onto a base plate using powder deposition welding in the 3D hybrid printer from DMG Mori depicted below and subsequently smoothed out by milling

that the greater the complexity of the component and the smaller the production volume, the more an additive method currently pays off. However, the costs have to be carefully analyzed on a case by case basis." One of the advantages of 3D printing, which per se is a complex technology, is the fact that because tools or casting molds are no longer necessary even the production of small volumes may be a cost-efficient option. Another benefit lies in the fact that 3D printing methods allow shapes to be produced that are impossible or only very difficult to make using conventional technologies. "A case in point are meandering cooling ducts for injection molding where you'd have to drill around a corner which, as we all know, doesn't work," explains Schaeffler's specialist.

Printer manufacturers have more homework to do too

Time savings are another advantage: "While today I still have to produce spare parts at our manufacturing site and then ship them to customers all over the world



In view of the growing importance of 3D printing, Schaeffler established a specialized department as early as in 2015: the "Additive Manufacturing Fab Shop" where smart tools and functional prototypes are produced using additive methods



1,768

3D metal printers were sold worldwide in 2017 – around 80% more than the year before. While the **market volume for all 3D printers in 2017 amounted to some US\$ 7.3 billion**, the products produced by them had a value of up to US\$ 250 billion.

Source: Wohlers Report 2018

10 times

faster than conventional models: a new 3D desktop printer from the Massachusetts Institute of Technology (MIT). **Due to a new technique, there's no need for supporting structures.** In just a few minutes, it produces components that used to be printed in one hour.

Source: MIT

I'll be able to print them for repair at flexible local manufacturing sites in the future," says Merklein. That saves time and money. However, not everything will be feasible using 3D printing in the future: "A cast component of which 250,000 units are required will not be produced by additive technology in more economical ways in the future either," says the expert. And besides that, a lot more development work, also on the part of the 3D printer manufacturers, will still be necessary before usable production parts are available in all areas where they make sense. "For many applications, reproducibility of the printing results, printing speed, automation of the processes and the range of suitable materials are still in need of significant improvement," says department head Merklein.

According to Schaeffler's expert, some more time will pass before significant improvements will hit the market. But that wouldn't mean less work for him and his team. The analysis of existing processes, employment of additive manufacturing in areas where this is already possible today – plus continually building the knowledge base about 3D printing methods by means of

in-house training programs – are already causing his team to work at full capacity today. "We're going to grow in the short to medium term," says Merklein. In any event, his vision of establishing additive manufacturing as an equivalent technology in Schaeffler's production system in ten years will not be achievable without a powerful team. "But that's where we'll need to arrive," says Merklein, "because at the end of the day, it will be tier 1 suppliers like Schaeffler providing automotive OEMs with components produced by additive manufacturing from 3D printers."



THE AUTHOR

Journalist **Denis Dilba** from Hamburg knew that the beginnings of 3D printing date back quite a while – but that it's 37 years did surprise him during his research for this article. At that time, he was three years old, so the author has to smile whenever others refer to it as a young technology.

MASTHEAD

Published by

Schaeffler AG
Industriestraße 1–3
D-91074 Herzogenaurach
www.schaeffler.com

Schaeffler Communications

Thorsten Möllmann (Senior Vice President Global Communications & Branding)
Martin Mai (Head of Newsroom, Head of Communications and Branding Europe)

Executive Editors

Volker Paulun, Stefan Pajung (Deputy)

Editor-in-Chief

Martin Mai

Coordination

Carina Chowanek, Anke von Lübken,
Julia Schneider

Editorial Team and Production

Speedpool GmbH

Pre-press Stage

Julien Gradtke, Mathias Mayer,
Diana Schröder

Copy Editors

David Feist, Volker Hummel,
Christoph Kirchner, Martin Knopp

Printing

Hofmann Druck Nürnberg GmbH & Co. KG

Graphic Design

Manuela Mrohs (AD),
Gökhan Agkurt,
Ivo Christov, Jana Herbst,
Janina Roll, Mariessa Rose,
Julian Schmaljohann,
Thomas Wildelau

Authors

Wiebke Brauer, Andreas Burkert, Denis Dilba, Marcus Efler,
Dr. Christian Heinrich, Martin Hyun, Oliver Jesgulke,
Jan Oliver Löffken, Roland Löwisch, Jens Möller, Dr. Laurin Paschek,
Carsten Paulun, Alexander von Wegner, Leopold Wieland

English Translation

Helga Oberländer



Photo/Illustration Credits

Front page: Chaloeophon Wanitcharoentham/Getty, Speedpool; p. 3: Schaeffler; pp. 4/5: Getty (3), Porsche; pp. 6/7: Alan Copson/Getty; p. 8: Andrew Peacock/Getty; p. 9: Jon Shireman/Getty, Daniel Ahmad/Wikipedia, Jonathan Knowles/Getty; p. 10: Manufacturers; p. 11: Kotomi Ito/Getty; p. 12: Terry O'Neill/Getty, Schaeffler Paravan GmbH; p. 13: Curti Aerospace, Getty; pp. 14–19: Getty (10), private; pp. 20–23: Getty (2), private; pp. 24/25: Jarno Schurgers/Red Bull Content Pool, private; p. 26: alengo/Getty, Alexis Boichard/Getty (2); p. 27: The Enthusiast Network; p. 28: Audi; p. 29: Ullstein/Getty, private; pp. 30/31: Brendan Hunter/iStock; pp. 32/33: JD Hancock/Flickr (3); pp. 34/35: Jean-Philippe Delberghe/unsplash.com, Brendan Hunter/iStock, JD Hancock/Flickr; pp. 36/37: De Agostini Picture Library; pp. 38–43: Schaeffler (10), private; pp. 44–46: Mariessa Rose/Speedpool; pp. 48/49: Laurence Mouton/Getty; p. 50: Corbis Historical, DigitalVision Vectors; p. 51: Daimler AG; pp. 52/53: Schaeffler (2), private; pp. 54–57: Getty (5), Schaeffler, private; pp. 58/59: Porsche; pp. 60/61: Thomas Barwick/Getty; pp. 62/63: Clive Mason/Getty, Lars Baron/Getty; pp. 64–73 Ford (3), Audi, RTA, Volkswagen (5), Daimler AG (2), Schaeffler; pp. 74–79: Rune Johansen/Getty; Schaeffler (5), private; pp. 80–83: Ingo Barends; p. 84: Matthias Mockenhaupt; p. 85: Schaeffler, private; p. 86: Rune Johansen/Getty; pp. 87–89: CERN (2), DESY; pp. 90/91: Viaframe/Getty; pp. 92–95: DigitalVision Vectors (2), NIO, Schaeffler; pp. 96–99: Volvo; pp. 100/101: Schaeffler, Aprilli Design Studio; pp. 102–105: Blutgruppe/Getty; p. 106: Foster + Partners; p. 107: Elisabeth Schmitt/Getty; pp. 108/109: Boeing, Victor Habbick Vision, private; pp. 110–113: Schaeffler (3), DMG Mori, Steve Debenport/Getty; p. 114: Schaeffler

tomorrow All previous issues



01/2015
**Mobility
for tomorrow**



02/2015
Productivity



03/2015
On the move



01/2016
Innovation

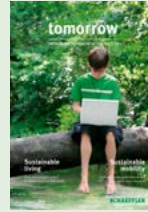

02/2016
Sustainability



03/2016
Digitalization

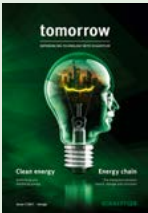

01/2017
Energy



02/2017
Motion



03/2017
Machines

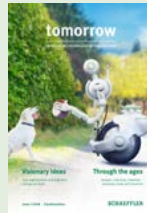

01/2018
Transformation

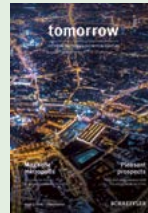

02/2018
Urbanization



03/2018
Acceleration

tomorrow has won recognition



Special Mention
"Communications
Design
Editorial"



Shortlist
"External
Publications"



Silver
Special Award
"International
Communication"



Special Mention
for "Outstanding
Branding"



**„Award of
Excellence“**
for cover (2/2017) and
cover story
"Electric Leader"



Gold Winner
for tomorrow digital,
"Websites: Customer
Magazine"



"Award of Distinction"
"Cover Design
Overall Design
Corporate Communications
Copy/Writing"



Gold Winner
"Websites
Feature Categories
Best Copy/Writing"



Gold Winner
"General Website
Categories-Magazine"

tomorrow on the internet



tomorrow as a **digital magazine**
with additional features
www.schaeffler-tomorrow.com



tomorrow for downloading
as an **e-paper or PDF**
www.schaeffler.de/tomorrow

tomorrow subscription

We'll be pleased to include
you on our **distribution list:**
tomorrow@schaeffler.com



WEB WORLDS

*Learn more about the
megatrends that are
changing the world at
schaeffler.com*