



We pioneer motion

THINKING AHEAD, PLANNING AHEAD

Our contribution to the chassis of the future.

Automated and autonomous driving are no longer just a futuristic vision: Schaeffler already has **system solutions** ready for implementation into future vehicle platforms – for enhanced safety and flexible interior design, as well as for increased driving comfort and the reduction of motion sickness. Safety and availability in every driving situation have top priority for us. Our innovative steering solutions are developed in accordance with ISO 26262 and classified as **ASIL D – the highest Automotive Safety Integrity Level**.

”BY-WIRE“-TECHNOLOGY: RELIABLE AND FUTURE-PROOF

+ 1 billion KM

More than one billion kilometers driven with not a single failure of the ”by-wire“ system

> 9,000

Systems in use worldwide: in cars, trucks, transporters and commercial vehicles of every description

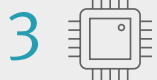

3 redundant control systems working in parallel



2 electric motors with 2 parallel windings for maximum safety

INNOVATIONS FOR FRONT AND REAR AXLES

”Brain“ and ”brawn“ for steering: supported by mechatronic actuators on the steering gear and steering wheel, the **Space Drive III ”by-wire“ system** as part of the **intelligent Front Wheel Steering (iFWS)** controls every driving manoeuvre. Steering signals are transmitted electronically. Constant availability is the top priority, secured by multiple redundancies within the Space Drive system.

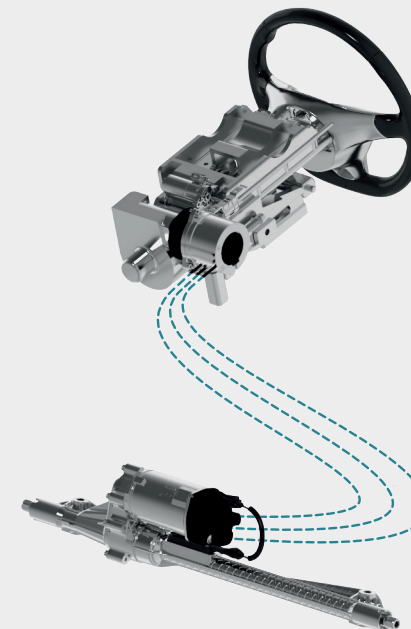

INTELLIGENT REAR WHEEL STEERING (iRWS)

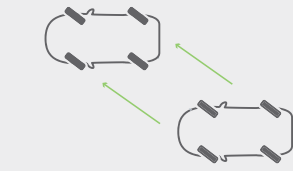

lane changes by means of Crab Walk

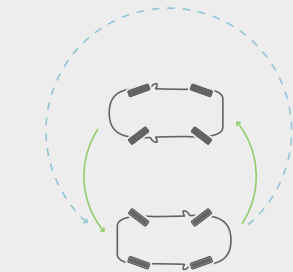

smaller turning radius

High maneuverability and a **tight turning radius** thanks to the iRWS save the driver's nerves in urban traffic and when parking. Relaxed driving at higher speeds is also manageable with ease: Safe and agile lane changes become a reality thanks to **matching steering lock angles on both the front and rear axle** – providing **maximum driving comfort** for all occupants.

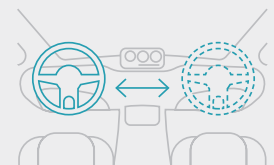

flexible interior design

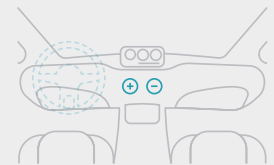

stowable steering components

Automated driving eliminates the need for manual steering. The stow-away function creates more space and opens up new possibilities in interior design.