



Railway drive bearings

Preferred types

Foreword

Schaeffler is, through its brands INA and FAG, one of the world's leading manufacturers of rolling and plain bearings. In close partnership with manufacturers and operators, carefully matched solutions are developed for any application in rail vehicles. The product portfolio includes wheelset bearings together with housings as well as bearings and components for traction motors and gearboxes, for wagon joints and tilting mechanisms, for doors and sliding panels.

Bearing arrangements for rail vehicles are subjected to extreme loads and are required to fulfil high safety standards. Schaeffler has more than 140 years of experience in the rail sector. We can thus offer comprehensive technical expertise, the highest quality and precise matching of products to any area of application. The reliability of the bearings is tested under extreme conditions on test rigs we have developed in-house. The railway test shop at the FAG Schweinfurt site is recognised and certified as a test facility for rail vehicle bearing arrangements by the Federal German Railway Authority.

It is also authorised by the DAP (German Accreditation System for Testing) to perform tests in the field "Performance capacity of wheelset bearings for railway applications" in accordance with DIN EN ISO/IEC 17025:2000.

Our services include expert application advisory work, rolling bearing calculations, testing and assembly. We have a close-meshed network of external sales engineers, service and sales technicians working worldwide for you to ensure short travel distances and rapid response times. As a special service, Schaeffler offers the skilled and economical reconditioning of railway bearings.

Preferred types

Schaeffler has decades of experience in the design and manufacture of rolling bearings for rail drives. Our application knowledge combined with our internally developed calculation tools make us a preferred partner for overcoming future challenges in conjunction with our customers.

The rolling bearings referred to in this publication are products that cover almost the entire size range for traction motor and railway gearbox applications. Most of these products already have many years of field experience in the corresponding applications. Our aim in stipulating specific bearing designs is to ensure good availability of the individual bearings and make bearing selection easier for our customers.

A selection of typical rolling bearing designs that have proved extremely suitable in operation is presented below. If you have any questions or require alternative versions, please do not hesitate to contact our specialists.

Naturally, all other bearing designs are still available from us, independently of this list, on request. An overview of the standard suffixes can be found in the appendix.

Contents

	Page
Traction motor bearings	
Requirements for traction motor bearings.....	4
Dimension tables	
Cylindrical roller bearings, standard	7
Cylindrical roller bearings, current-insulated.....	8
Cylindrical roller bearings, hybrid	9
Deep groove ball bearings, current-insulated	10
Deep groove ball bearings, hybrid.....	11
Railway gearbox bearings	
Requirements for railway gearbox bearings	12
Dimension tables	
Cylindrical roller bearings, standard	14
Tapered roller bearings, standard	16
Four point contact bearings, standard.....	18

Traction motor bearings

Requirements for traction motor bearings

Modern electric drives for the railway industry are subject to certain fundamental requirements such as cost-efficiency, reliability, operational security, adequate service life and low maintenance outlay. The fulfilment of these fundamental requirements is heavily influenced by the acting forces, additional loads and environmental influences. Depending on the drive concept, different rolling bearing solutions can be selected to achieve a bearing arrangement that is efficient, operationally reliable and cost-effective.

One of the additional loads encountered with traction motor bearings in particular is current passage. In general, it is difficult to eliminate the causes of electrical currents in the rolling bearing. Nevertheless, bearing damage can be prevented if it is possible to stop or significantly reduce the flow of current. Current-insulated rolling bearings, coated with Insutect A, are now available for this purpose in numerous designs. The components that should be insulated are dependent on the type of electrical currents occurring.

A premium product alternative to the Insutect A bearings is available in the form of FAG hybrid bearings. The rings of the hybrid bearings are made from rolling bearing steel and the rolling elements are made from ceramic. The hybrid bearings are identified by the prefix HC. The rolling elements are extremely resistant to wear and perform the function of current insulation. In addition to a high resistance value, FAG hybrid bearings offer a very low capacitance and thus optimal protection against high-frequency currents in converter operation. In addition to this effect, hybrid bearings also facilitate higher speeds, have better emergency running characteristics and an extended relubrication interval.

Naturally, all other bearing designs are still available from us, independently of this list, on request.

Figure 1
Cylindrical roller bearing
NU212-E-XL-M1-S1-C4



001.8D9F2

Figure 2
Current-insulated
cylindrical roller bearing
NU212-E-XL-M1-J20AA-C4,
coated with Insutect A



001.8D9E6

Figure 3
Hybrid cylindrical roller bearing
HCNU212-E-XL-M1-F1-C4



001.8D9E0

Traction motor bearings

Figure 4
Current-insulated
deep groove ball bearing
6215-M-j20AA

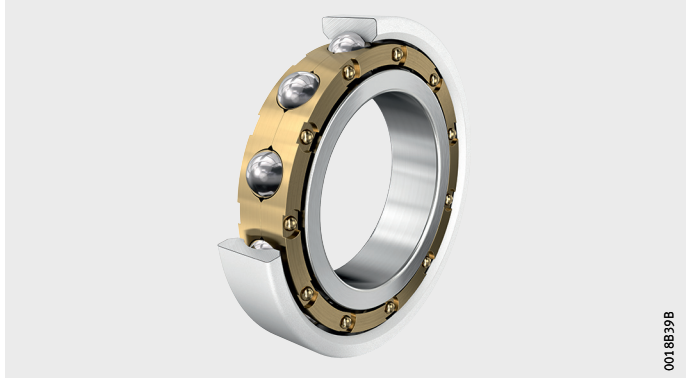

00188398

Figure 5
Hybrid deep groove ball bearing
HC6215-M

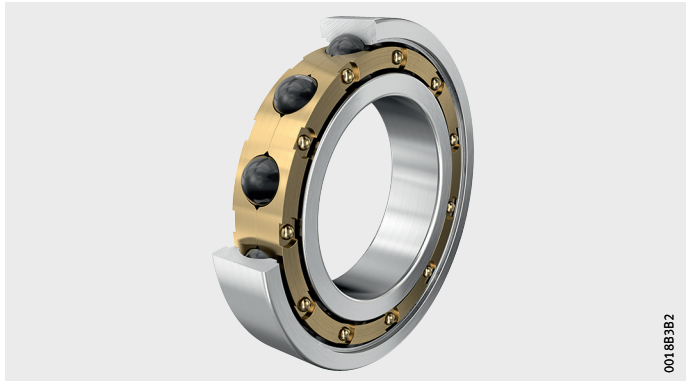

00188382

Cylindrical roller bearings

Standard

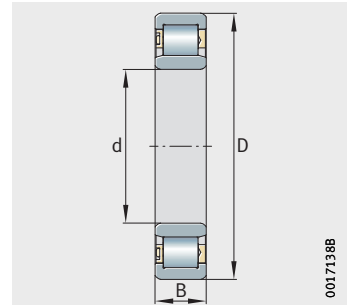

Dimensions

Dimension table - Dimensions in mm							
Designation	Mass m ≈ kg	Dimensions			Basic load ratings		Limiting speed n min ⁻¹
		d	D	B	dyn. C N	stat. C ₀ N	
NU310-E-XL-M1-F1-C3	1,3	50	110	27	130 000	113 000	10 100
NU212-E-XL-M1-S1-C4	0,9	60	110	22	112 000	103 000	10 000
NJ314-E-XL-M1-F1-C4	3,1	70	150	35	242 000	222 000	7 200
NU214-E-XL-M1-F1-C4	1,3	70	125	24	140 000	137 000	8 800
NU314-E-XL-M1-F1-C4	3,06	70	150	35	242 000	222 000	7 200
NUP314-E-XL-M1-F1-C3	3,2	70	150	35	242 000	222 000	7 200
NU215-E-XL-M1-F1-C4	1,41	75	130	25	154 000	156 000	8 500
NU217-E-XL-M1-F1-C4	2,1	85	150	28	194 000	194 000	7 200
NH318-E-XL-M1-F1-C4	6,9	90	190	55	370 000	350 000	5 500
NJ318-E-XL-M1-F1-C4	6,2	90	190	43	370 000	350 000	5 500
NU1018-XL-M1-F1-C4	1,3	90	140	24	111 000	124 000	8 400
NUP318-E-XL-M1-F1-C4	6,3	90	190	43	370 000	350 000	5 500
Z-576110.ZL	2,8	90	160	45	182 000	217 000	5 200
NU319-E-XL-M1-F1-C4	7	95	200	45	390 000	380 000	5 300
NUP319-E-XL-M1-F1-C4	7,3	95	200	45	390 000	380 000	5 300
F-807919.01.NJ320-E	8,6	100	215	47	360 000	395 000	4 850
NU322-E-XL-M1-F1-C4	11,5	110	240	50	520 000	510 000	4 350
NJ324-E-XL-M1A-F1-R155-195	15,6	120	260	55	610 000	600 000	3 950
NU224-E-XL-M1-F1-H67C-C4	6,4	120	215	40	390 000	415 000	4 900
NU324-E-XL-M1-F1-C4	15,2	120	260	55	610 000	600 000	3 950
NU326-E-XL-M1-F1-C4	18,4	130	280	58	720 000	720 000	3 700
Z-558540.04.ZL	18,3	130	280	58	770 000	760 000	2 600
NU328-E-XL-M1-F1-C4	22,1	140	300	62	790 000	800 000	3 450
F-804577.01.NU330-E	27	150	320	65	760 000	930 000	3 200
NU330-E-XL-M1A-F1-C4	27,4	150	320	65	900 000	930 000	3 200
NU330-E-XL-M1-F1-C4	26,8	150	320	65	900 000	930 000	3 200
NUP1030-XL-M1-F1-C4	5,2	150	225	35	248 000	310 000	5 100
NU332-E-M1-F1-C4	41,2	160	340	68	860 000	1 060 000	3 000
F-801488.01.NU2236-E	30,7	180	320	86	1 180 000	1 490 000	3 200
NU1036-XL-M1-F1-C4	10,5	180	280	46	425 000	520 000	3 900

Cylindrical roller bearings

Current-insulated

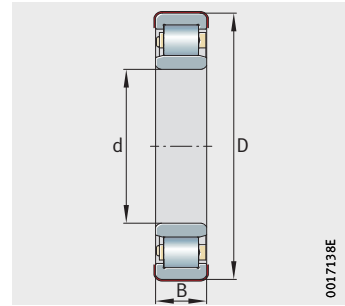

Dimensions

0017138E

Dimension table · Dimensions in mm

Designation	Mass m ≈ kg	Dimensions			Basic load ratings		Limiting speed n min ⁻¹
		d	D	B	dyn. C N	stat. C ₀ N	
NU210-E-XL-M1-F1-J20AA-C3H#NA	0,6	50	90	20	75 000	69 000	12 600
NU211-E-XL-M1-S1-J20AA-C4	0,8	55	100	21	99 000	95 000	11 000
NUB1011-XL-M1-F1-J20AA-C4	0,5	55	90	26	49 500	50 000	13 500
NU1012-XL-M1-F1-J20AA-C4	0,5	60	95	18	52 000	55 000	12 800
NU212-E-XL-M1-J20AA-C4	0,9	60	110	22	112 000	103 000	10 000
NU1013-XL-M1-F1-J20AA-C4	0,5	65	100	18	53 000	58 000	12 200
NU213-E-XL-M1-F1-J20AA-C4	1,2	65	120	23	127 000	119 000	9 200
NU1014-XL-M1-F1-J20AA-C4	0,7	70	110	20	77 000	81 000	10 700
NU214-E-XL-M1-F1-J20AA-C4	1,3	70	125	24	140 000	137 000	8 800
NU215-E-XL-M1-F1-J20AA-C4	1,4	75	130	25	154 000	156 000	8 500
NU315-E-XL-M1-J20AA-C4	3,7	75	160	37	285 000	265 000	6 600
NU216-E-XL-M1-F1-J20AA-C4	1,8	80	140	26	166 000	168 000	7 900
NU1017-XL-M1-F1-J20AA-C4	1	85	130	22	93 000	103 000	9 000
NJ2218-E-XL-M1-F1-J20AA-C4	3,5	90	160	40	285 000	315 000	6 800
NJ318-E-XL-M1-F1-J20AA-C4	6,2	90	190	43	370 000	350 000	5 500
NU1018-XL-M1-F1-J20AA-C4	1,3	90	140	24	111 000	124 000	8 400
F-564169.02.NUB219-E	3,5	95	170	43	237 000	234 000	6 300
NU219-E-XL-M1-F1-J20AA-C4	3,1	95	170	32	260 000	265 000	6 300
F-564372.01.ZL-M15CS	3,8	100	180,02	34	280 000	290 000	5 900
NJ320-E-XL-M1-F1-J20AA-C4	8,8	100	215	47	450 000	425 000	4 850
NUB220-E-XL-TVP2-F1-J20AA-C4	3,7	100	180	46	295 000	305 000	4 550
F-585063.ZL	11,4	110	240	50	520 000	510 000	4 350

Cylindrical roller bearings

Hybrid

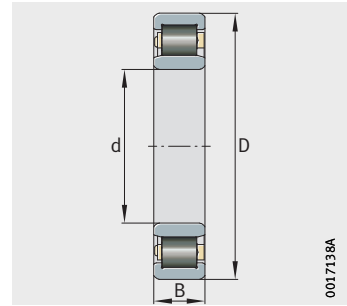

Dimensions

Dimension table - Dimensions in mm

Designation	Mass m ≈ kg	Dimensions			Basic load ratings		Limiting speed ¹⁾ n min ⁻¹
		d	D	B	dyn. C N	stat. C ₀ N	
F-583158.ZL	0,5	50	90	20	64 000	65 000	12 600
HCNU1011-E-XL-M1-F1-C4	0,4	55	90	18	62 000	62 000	13 000
HCNU212-E-XL-M1-F1-C4	0,8	60	110	22	95 000	97 000	9 500
HCNU1014-XL-M1-F1-C4	0,6	70	110	20	77 000	81 000	10 700
HCNU1015-XL-M1-F1-C4	0,6	75	115	20	66 000	80 000	10 300
HCNU215-E-XL-M1-C3H	1,2	75	130	25	154 000	156 000	8 500
HCNU1018-XL-M1-F1-C4	1,2	90	140	24	94 000	124 000	8 400

¹⁾ 20% higher limiting speed compared to standard.

Deep groove ball bearings

Current-insulated

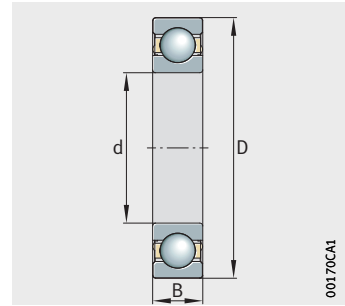

Dimensions

Dimension table · Dimensions in mm

Designation	Mass m ≈ kg	Dimensions			Basic load ratings		Limiting speed n min ⁻¹
		d	D	B	dyn. C N	stat. C ₀ N	
6211-M-S1-J20AA-C5	0,733	55	100	21	46 000	29 000	12 300
6212-M-J20AA-C5	0,95	60	110	22	57 000	36 500	12 100
6014-M-P6-J20AA-C4H	0,71	70	110	20	40 500	31 000	11 200
6214-M-J20AA-C4	1,28	70	125	24	66 000	44 000	10 600
6215-M-J20AA-C4	1,42	75	130	25	70 000	49 000	10 200
6016-M-P6-J20AA-C5H	0,99	80	125	22	51 000	40 000	9 700
6216-M-P6-J20AA-C5H	1,74	80	140	26	77 000	55 000	9 500
6316-M-P6-J20AA-C5	4,41	80	170	39	131 000	87 000	7 000
6217-M-J20AA-C4	2,16	85	150	28	89 000	64 000	8 800
6318-M-P6-J20AA-C5H	6,11	90	190	43	142 000	102 000	6 300
6319-M-J20AA-C4	6,94	95	200	45	154 000	113 000	6 000
6220-M-J20AA-C4	3,85	100	180	34	13 000	93 000	6 500

Deep groove ball bearings

Hybrid

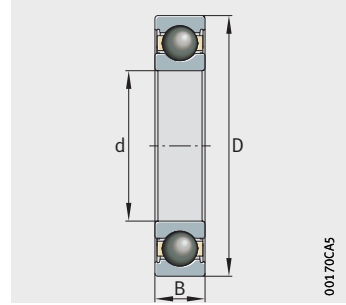

Dimensions

Dimension table - Dimensions in mm

Designation	Mass m ≈ kg	Dimensions			Basic load ratings		Limiting speed n min ⁻¹
		d	D	B	dyn. C N	stat. C ₀ N	
HC6210-N1-M-P6-S0-C5L	0,48	50	90	20	43 000	27 000	16 400
HC6211-M-C4H	0,65	55	100	21	51 000	32 500	12 300
HC6212-M-C4	0,94	60	110	22	57 000	35 000	14 600
HC6213-M-C4L	1,05	65	120	23	63 000	39 500	13 400
HC6214-M-C4	1,23	70	125	24	66 000	42 000	12 800
HC6215-M-C4H	1,18	75	130	25	70 000	47 000	12 200
HC6216-M-P6-C5H	1,49	80	140	26	77 000	53 000	11 400
HC6217-M-C4	2,14	85	150	28	85 000	61 000	9 600
HC6218-M-F1-C4	2,66	90	160	30	97 000	70 000	8 900

Railway gearbox bearings

Requirements for railway gearbox bearings

Rolling bearings in railway gearboxes must withstand a wide variety of operating conditions and complex environmental influences.

Not only are high static and, in particular, dynamic loads present in the form of vibrations and shocks, but the rolling bearings are also operated intermittently below the permissible minimum load.

Increasingly high input speeds require low-friction products and operation under all possible climatic conditions is assumed.

A further objective aimed at increasing the availability of the vehicles is to extend the maintenance intervals. Robust rolling bearing designs are therefore a fundamental requirement for ensuring the reliable and problem-free operation of gearboxes and vehicles.

Figure 1
Cylindrical roller bearing NU

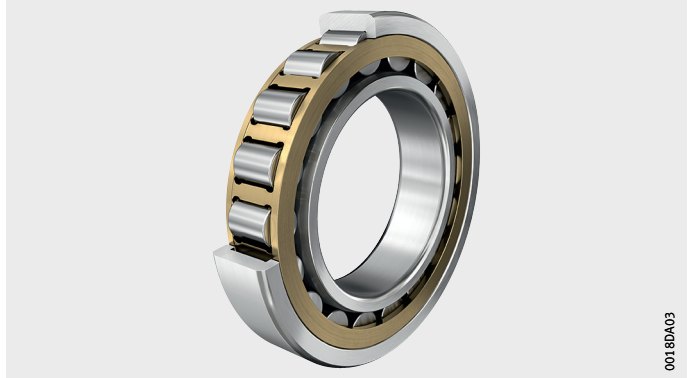

00180A03

Figure 2
Tapered roller bearing 30215-XL



001883AB

Figure 3
Four point contact bearing QJ215

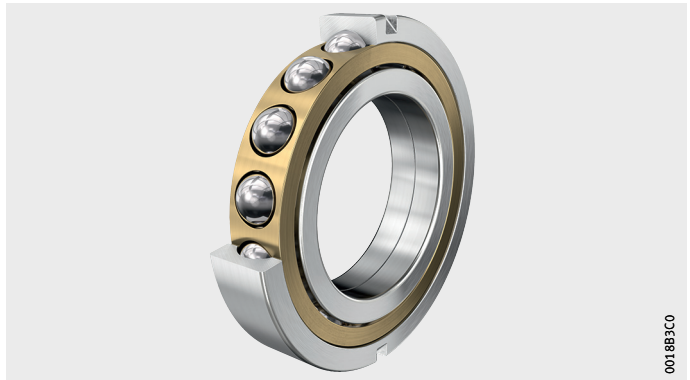

001883C0

Cylindrical roller bearings

Standard

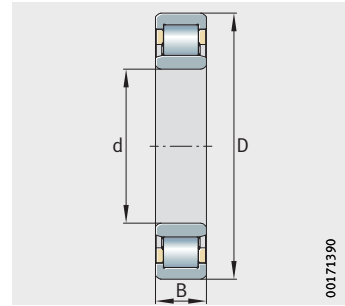

Dimensions

00171390

Dimension table · Dimensions in mm

Designation	Mass m ≈ kg	Dimensions			Basic load ratings		Limiting speed n min ⁻¹
		d	D	B	dyn. C N	stat. C ₀ N	
NJ211-E-XL-N-MPAX-C3	0,7	55	100	21	99 000	95 000	11 300
NJ2311-E-XL-MPAX-C3	2,5	55	120	43	235 000	230 000	9 100
NU211-E-N1-XL-MPAX-C3	0,7	55	100	21	99 000	95 000	11 300
NJ212-E-XL-N1-MPAX-C3	0,9	60	110	22	112 000	103 000	10 000
NU212-E-XL-N1-MPAX-C3	0,9	60	110	22	112 000	103 000	10 000
NJ2313-E-XL-MPAX-C3H/NA	3,7	65	140	48	295 000	285 000	7 700
NJ313-E-XL-MPAX-C3	2,6	65	140	33	214 000	191 000	7 700
NU213-E-XL-MPAX-C4	1,2	65	120	23	128 000	120 000	9 200
NU2313-E-XL-MPAX-C3H/NA	3,6	65	140	48	295 000	285 000	7 700
NJ214-E-XL-N1-MPAX-C3	1,3	70	125	24	141 000	138 000	8 800
NJ2314-E-XL-MPAX-C3H/NA	4,5	70	150	51	325 000	325 000	7 200
NJ314-E-XL-MPAX-C4	3,1	70	150	35	242 000	222 000	7 200
NU214-E-XL-N1-MPAX-C3	1,2	70	125	24	141 000	138 000	8 800
NJ215-E-XL-MPAX-C4H/NA	1,4	75	130	25	155 000	157 000	8 500
NJ2215-E-XL-MPAX-C3	1,8	75	130	31	192 000	208 000	8 500
NJ315-E-XL-MPAX-C3	3,7	75	160	37	285 000	265 000	6 600
NU215-E-XL-N1-MPAX-C3	1,4	75	130	25	155 000	157 000	8 500
NU2215-E-XL-N1-MPAX-C3	1,8	75	130	31	192 000	208 000	8 500
NJ1016-XL-MPAX-C3	1	80	125	22	91 000	99 000	9 400
NJ216-E-XL-N1-MPAX-C3	1,8	80	140	26	166 000	168 000	7 900
NJ2216-E-XL-N1-MPAX-C3	2,2	80	140	33	221 000	244 000	7 900
NU216-E-XL-MPAX-C4	1,7	80	140	26	166 000	168 000	7 900
NU316-E-XL-MPAX-C3	4,4	80	170	39	300 000	275 000	6 200
NJ1017-XL-MPAX-C3	1	85	130	22	93 000	103 000	9 000
NJ2217-E-XL-N1-MPAX-C3	2,8	85	150	36	255 000	275 000	7 200
NU217-E-XL-MPAX-C4	2,1	85	150	28	203 000	206 000	7 200
NU2217-E-XL-MPA-C4H/NA	2,8	85	150	36	255 000	275 000	7 200
NJ218-E-MPAX-C4	2,6	90	160	30	215 000	217 000	6 800
NJ2218-E-XL-MPA-C4	3,7	90	160	40	285 000	315 000	6 800
NU218-E-XL-N-MPAX-C3	2,8	90	160	30	215 000	217 000	6 800
NJ219-E-XL-MPAX-C3	3,2	95	170	32	260 000	265 000	6 300
NJ2219-E-XL-MPAX-C3	4	95	170	43	340 000	370 000	6 300
NU219-E-XL-MPAX-C3	3,1	95	170	32	260 000	265 000	6 300

Cylindrical roller bearings

Standard

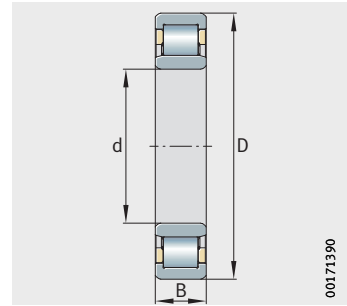

Dimensions

00171390

Dimension table (continued) · Dimensions in mm

Designation	Mass m ≈ kg	Dimensions			Basic load ratings		Limiting speed n min ⁻¹
		d	D	B	dyn. C N	stat. C ₀ N	
NJ220-E-XL-MPAX-C3	3,8	100	180	34	295 000	305 000	5 900
NJ2220-E-XL-MPAX-C3	5,3	100	180	46	395 000	445 000	5 900
NJ320-E-XL-MPAX-C3	8,7	100	215	47	450 000	425 000	4 850
NU220-E-XL-MPAX-C3H/NA	3,8	100	180	34	295 000	305 000	5 900
NU2220-E-XL-MPAX-C4	5,2	100	180	46	395 000	445 000	5 900
NU2222-E-XL-MPAX-C4H/NA	7,4	110	200	53	455 000	520 000	5 300
NU222-E-XL-MPAX-C3	5,3	110	200	38	345 000	365 000	5 300
NU2322-E-XL-MPAX-R210-240	18,3	110	240	80	790 000	870 000	4 350
NJ1024-E-XL-MPAX-C3	2,5	120	180	28	175 000	208 000	6 400
NU2224-E-XL-MPAX-C3	9,1	120	215	58	530 000	610 000	4 900
NU226-E-XL-MPAX-C3	7,2	130	230	40	425 000	445 000	4 550
NU228-E-XL-MPAX-C3	9,2	140	250	42	460 000	510 000	4 250
NU230-E-XL-N-MPAX-C4H/NA	11,6	150	270	45	520 000	590 000	3 950
NJ1032-XL-MPAX-C3	6,2	160	240	38	290 000	355 000	4 650
NJ1034-XL-MPAX-C3	8,3	170	260	42	350 000	435 000	4 300
NU1036-XL-MPAX-C3	10,6	180	280	46	425 000	520 000	3 900
NJ1038-XL-MPAX-T51A-C3	11,2	190	290	46	435 000	550 000	3 800
NU1944-E-XL-N1-MPAX-C3	7,8	220	300	38	395 000	560 000	3 750
NUP1944-E-XL-MPAX-C3	8,2	220	300	38	395 000	560 000	3 750
Z-566185.NJ1044	19	220	340	56	510 000	77 000	3 150
NU1964-MPAX-C4	25,5	320	440	56	620 000	1 090 000	2 500
NU1968-E-MPAX-C3	26,3	340	460	56	700 000	1 250 000	2 350
NUP1968-E-MPAX-C3	27,4	340	460	56	700 000	1 250 000	2 350
NJ1876-MPAX-C3	19,8	380	480	46	495 000	1 010 000	2 420

Tapered roller bearings

Standard

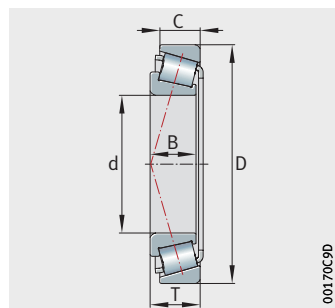

Dimensions

00170C9D

Dimension table · Dimensions in mm

Designation	Mass m ≈ kg	Dimensions					Basic load ratings		Limiting speed n min ⁻¹
		d	D	B	C	T	dyn. C N	stat. C ₀ N	
T7FC045-XL-S1	0,93	45	95	26,5	20	29	105 000	109 000	8 100
T7FC055-XL-S1	1,59	55	115	31	23,5	34	152 000	165 000	6 600
T7FC060-XL-S1	2,03	60	125	33,5	26	37	181 000	200 000	6 100
31313-XL-S1	2,36	65	140	33	23	36	193 000	188 000	5 500
T7FC070-XL-S1	2,63	70	140	35,5	27	39	208 000	237 000	5 300
31315-XL-S1	3,46	75	160	37	26	40	240 000	236 000	4 850
F-808708.32016-X-XL-S1-H144	1,28	80	125	29	22	29	162 000	212 000	6 000
33217-XL-S1	3,6	85	150	49	37	49	345 000	440 000	4 950
F-801627.32018-X-XL-S1	1,8	90	140	30	24	32	195 000	255 000	5 400
F-801573.32218-XL-S1	3,48	90	160	40	34	42,5	310 000	360 000	4 800
F-808858.32219-XL-S1	4,2	95	170	43	37	45,5	355 000	420 000	4 500
F-809631.TR1-H144	3,75	100	180	34	29	37	250 000	325 000	4 000
32021-X-XL-S1	2,45	105	160	35	26	35	238 000	330 000	4 650
F-804120.32026-X-XL-S1	4,92	130	200	45	34	45	385 000	550 000	3 650
32028-X-XL-S1	5,4	140	210	45	34	45	400 000	590 000	3 450
F-804622.TR1	2,28	146,05	193,675	28,575	23,02	28,575	162 000	310 000	3 500
F-809012.TR1	3,68	152,4	203,2	41,275	34,925	41,275	255 000	540 000	3 200
F-801093.TR1-H144	2,89	177,8	227,012	30,162	23,02	30,162	187 000	395 000	2 950
Z-579007.TR1-H144	6,4	180	250	45	34	45	340 000	650 000	2 600
F-804680.TR1	3,48	184,15	235,229	33	28	34	234 000	485 000	2 800
F-808438.TR1	6,9	190	260	44	35	46	405 000	680 000	2 750
F-801427.01.TR1-H144	4,1	195	250	33	28	34	243 000	520 000	2 650
F-801019.TR1-H144	5,3	196,85	257,175	39,688	30,163	39,688	260 000	590 000	2 550
F-801094.TR1-H144	3,55	196,85	254	27,783	21,433	28,575	201 000	400 000	2 700
F-809830.01.TR1	9,3	199,949	282,575	49,212	36,512	46,038	380 000	680 000	2 700

Tapered roller bearings

Standard

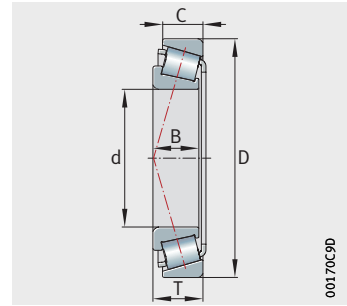

Dimensions

Dimension table (continued) · Dimensions in mm

Designation	Mass m ≈ kg	Dimensions					Basic load ratings		Limiting speed n min ⁻¹
		d	D	B	C	T	dyn. C N	stat. C ₀ N	
Z-548100.01.TR1-H144	7,4	200,025	276,225	46,038	34,133	42,862	340 000	620 000	2 420
Z-548101.01.TR1-H144	7	203,987	276,225	46,038	34,133	42,862	340 000	620 000	2 420
Z-573160.TR1-H144	7,3	210	285	40	33	41	365 000	730 000	2 310
F-804989.TR1	6,9	213	285	40	33	41	365 000	730 000	2 310
F-801860.TR1-H144	5,4	215,9	290,01	31,75	22,225	31,75	178 000	360 000	2 450
Z-576050.TR1-H144	7,8	215,9	285,75	46,038	34,925	46,038	360 000	790 000	2 240
Z-578695.01.TR1	7,9	216,408	285,75	49,213	34,925	46,038	360 000	790 000	2 240
F-562964.TR1	6,6	216,5	285	40	33	41	365 000	730 000	2 310
Z-563839.TR1-H144	6,2	220	285	40	33	41	365 000	730 000	2 310
F-801813.TR1	9,5	223,175	300	48	38	50	410 000	890 000	2 170
F-807285.TR1-H144	5,5	231,775	300,038	31,75	23,813	33,338	238 000	480 000	2 320
F-808788.TR1	10,8	231,775	317,5	52,388	36,512	47,625	455 000	830 000	2 090
Z-562497.TR1-H144	8,2	240	320	39	30	42	380 000	670 000	2 070
Z-547734.TR1	15	255,6	342,9	63,5	44,45	57,15	500 000	1 150 000	1 870
Z-547734.01.TR1	15,3	255,6	342,9	63,5	44,45	57,15	460 000	1 140 000	1 870
Z-547733.01.TR1	20,7	257,175	358,775	76,2	53,975	71,438	660 000	1 370 000	1 800
Z-547733.TR1	20,7	257,175	358,775	76,2	53,975	71,438	720 000	1 370 000	1 800
F-801861.TR1	5,3	266,56	325,438	33,47	25,48	29,5	206 000	470 000	2 130
Z-517132.TR1-H144	12,3	292,1	374,65	47,625	34,925	47,625	490 000	1 080 000	1 740

Four point contact bearings

Standard

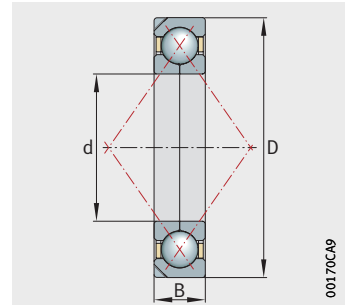

Dimensions

Dimension table · Dimensions in mm

Designation	Mass m ≈ kg	Dimensions			Basic load ratings		Limiting speed n min ⁻¹
		d	D	B	dyn. C N	stat. C ₀ N	
QJ211-XL-N2-MPA-F59-C4	0,75	55	100	21	77 000	71 000	12 400
QJ212-XL-N2-MPA-F59-C4	0,945	60	110	22	94 000	87 000	11 200
QJ213-XL-N2-MPA-F59-C4	1,2	65	120	23	106 000	104 000	10 300
F-572543.KLQ	1,41	70	125	25	100 000	106 000	9 000
QJ214-XL-N2-MPA-F59-C4	1,3	70	125	24	118 000	114 000	9 700
F-612995.KLQ	4	75	170	35,2	128 000	130 000	6 200
QJ215-XL-N2-MPA-F59-C4	1,45	75	130	25	123 000	122 000	9 200
QJ216-XL-N2-MPA-F59-C4	1,78	80	140	26	136 000	137 000	8 600
F-801297.01.KLQ	2,3	85	149	28	153 000	160 000	8 000
QJ217-XL-N2-MPA-T42F	2,31	85	150	28	158 000	160 000	8 000
QJ218-XL-N2-MPA-F59-C4	2,8	90	160	30	181 000	185 000	7 400
QJ219-N2-MPA-F59-C4	3,41	95	170	32	190 000	212 000	7 000
QJ220-N2-MPA-F59-C4	4,02	100	180	34	224 000	241 000	6 600
QJ221-N2-MPA-F59-C4	4,81	105	190	36	233 000	255 000	6 200
QJ222-N2-MPA-F59-C4	5,58	110	200	38	249 000	285 000	5 900
QJ224-N2-MPA-F59-C4	6,74	120	215	40	285 000	340 000	5 400
QJ226-N2-MPA-F59-C4	7,66	130	230	40	295 000	370 000	5 100
QJ228-N2-MPA-F59-C4	9,69	140	250	42	315 000	420 000	4 700
QJ230-N2-MPA-A250-280	12,2	150	270	45	350 000	485 000	4 350
QJ1032-N2-MPA-F59-C4	6,35	160	240	38	231 000	335 000	4 750
QJ1034-N2-MPA-F59-C4	8,68	170	260	42	295 000	430 000	4 350

**Schaeffler Technologies
AG & Co. KG**

Georg-Schäfer-Straße 30
97421 Schweinfurt
Germany

www.schaeffler.de/en
info.de@schaeffler.com

In Germany:

Phone 0180 5003872

From other countries:

Phone +49 9721 91-0

All information has been carefully compiled and checked by us, but we cannot guarantee complete accuracy. We reserve the right to make corrections. Therefore, please always check whether more up-to-date or amended information is available. Printing, including excerpts, is only permitted with our approval.

© Schaeffler Technologies AG & Co. KG
TPI 266 / en-GB / DE / 2021-05