

# FAG Wheelset Bearings for Innovative Light Regional Express Train



Examples of Application Engineering

Publ. No. WL 07 517 EA



LIREX experimental train

Courtesy of ALSTOM LHB GmbH

The LIREX (Light Innovative Regional EXpress) experimental train is an advanced development of the Copenhagen commuter train that has been developed through a joint venture of the German railways, the railway industry and the state Sachsen-Anhalt for attractive electric or diesel-electric suburban trains of the future.

Main targets of development:

- Implementation, testing and optimisation of innovative technologies and components
- Modular vehicle concept at reduced operating cost
- Example of tomorrow's suburban passenger transport provided by the German Federal Railways.

For the first time, a single-wheelset running gear is used with a Federal Railway vehicle. The reduced running gear mass adds to the travelling comfort and saves the rail superstructure.

**FAG supplies wheelset bearings consisting of split housings and cylindrical roller bearings, which were specially designed for the LIREX.**

## Vehicle data

Maximum static wheelset load	21 t
Maximum speed	160 km/h

## Running gear

The end cars have just a single-wheelset running gear, KERF, and are supported, at their opposite end, by a neighbouring car. The middle cars are shorter and have two running gears.

### KERF single-wheelset running gear

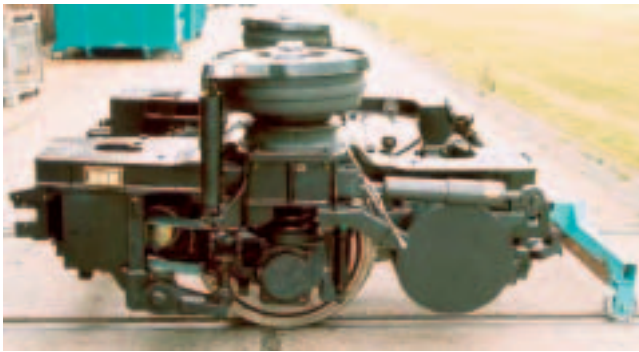

### FAG wheelset bearing for LIREX

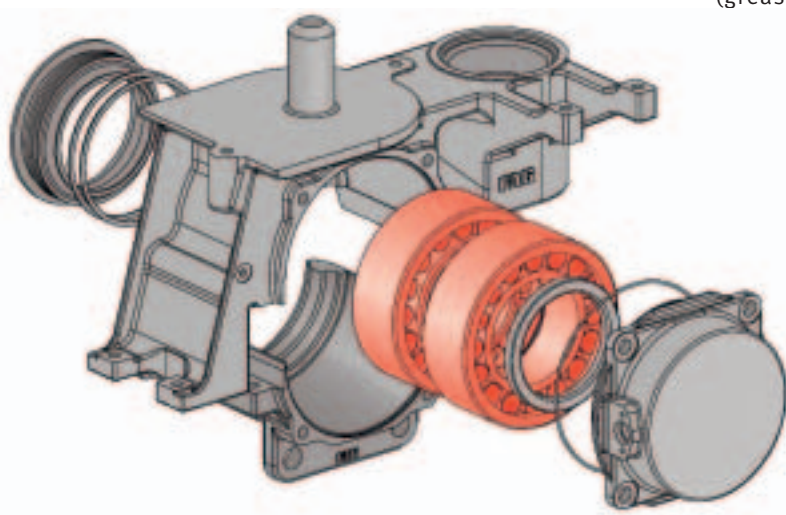

## Wheelset journal roller bearings

The bearing unit consists of a split housing with varying cover designs, sealing system, cylindrical roller bearings and grease.

## Housing

- Material: Spheroidal graphite cast iron
- Split design for fast dismounting the wheelset without the need to remove springs, shock-absorbing and guiding elements
- Compact construction by central arrangement of the primary spring
- The adapters for primary spring, wheelset guide, and pneumatic spring suspension integrated in the housing top
- Wheel-facing end sealed by labyrinth reinforced with lamellar rings

## Rolling bearings

- Well-proven cylindrical roller bearings **WJ120x215TVP** and **WJP120x215P.TVP** with polyamide cages for long maintenance intervals.  
References: ET423 and VT641 (both German Federal Railways), XTER 73500 (SNCF), S-TØG Copenhagen (DSB).
- Separable bearings ensure easy mounting and dismounting and quick access to the functional surfaces during inspections.
- Initial mounting and greasing by FAG service staff (grease approved by DB)

### FAG Kugelfischer AG

Product line Railway  
Postfach 1260  
D-97419 Schweinfurt  
Tel.: +49 9721 912366  
Fax: +49 9721 913788  
E-mail: rail\_transport@fag.de  
www.fag.com