

# Mounting manual for Speed Sensor 176904.17 and 176904.29 with adjustable angle

**You will only require this manual if you need to change the angle on the Speed Sensor.**

Only open and close the knurled nut using the GlenAir special pliers (article no. 600-079-06SS-18/19 0931):

- Push the plug onto the connector. Ensure that the slot in the plug matches the guide bar on the connector.
- Tighten the bayonet fastening firmly until it locks into place, see Figure ①.

## ! Caution

**Never try to loosen the nut by pulling the angled plug! This will damage the cables inside the angled plug!**

**Only loosen the nut on the angled plug using the special pliers! Otherwise this will damage the knurled nut!**

- Rotate the nut by a maximum of 2 revolutions.
- Only rotate the angled plug by up to  $\pm 60^\circ$ , see Figure ②.
- Only secure the screw connection using means of screw locking if this is explicitly specified in the drawing.
- Tighten the nut by hand.
- Fully tighten the nut using the GlenAir special pliers.

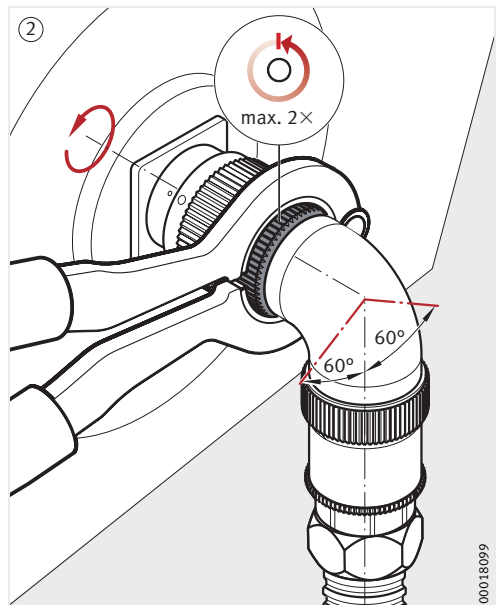
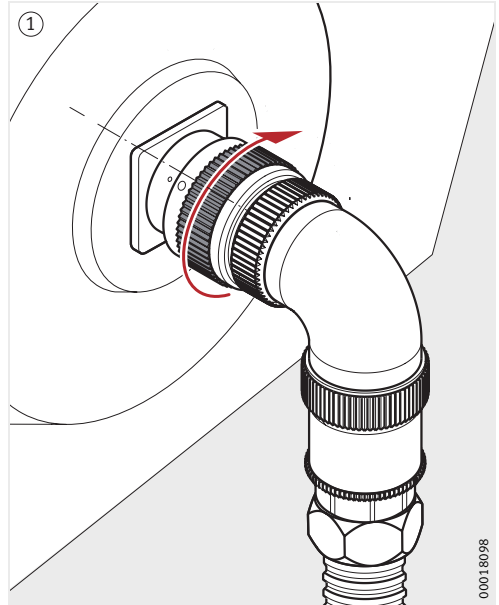

**Mounting may only be carried out by trained personnel.**

**Schaeffler Technologies  
GmbH & Co. KG**

Georg-Schäfer-Straße 30  
97421 Schweinfurt  
Germany

Phone +49 9721 91-3998

Fax +49 9721 91-3788

E-Mail [rail\\_transport@schaeffler.com](mailto:rail_transport@schaeffler.com)

Internet [www.fag.de](http://www.fag.de), [www.ina.de](http://www.ina.de)

Every care has been taken to ensure the correctness of the information contained in this publication but no liability can be accepted for any errors or omissions.

We reserve the right to make technical changes.

© Schaeffler Technologies GmbH & Co. KG

Issued: 2011, November

This publication or parts thereof may not be reproduced without our permission.

MON 82 US-D