



Entraînement des accessoires

Décembre 2017























Nouveautés VL-VUL



SCHAEFFLER  
AUTOMOTIVE AFTERMARKET

## Symbole und Abkürzungen

	Courroie trapézoïdale
	Poulie roue libre, alternateur
	Courroie trapézoïdale à nervures
	Poulie renvoi/transmission, courroie trapézoïdale à nervures
	Poulie, vilebrequin
	Tendeur, courroie trapézoïdale à nervures Poulie-tendeur, courroie trapézoïdale à nervures
	Jeu de courroies trapézoïdales à nervures
	Dynamo
<b>A/C</b>	Compresseur de climatisation pour véhicules avec système de climatisation pour véhicules avec climatiseur automatique
	Pompe de la direction assistée pour véhicules avec direction assistée
	Année à partir de Année jusqu'à
	Diamètre [mm]
	N° de châssis à partir de N° de châssis jusqu'à
	Version d'équipement
	N° de moteur de N° de moteur à
	Code moteur Type de moteur
	boîte de vitesses manuelle
	Boîte automatique entièrement automatique
<b>#</b>	pour numéro OE
<b>START/STOP</b>	pour véhicules avec fonction Stop/Start
	pour véhicules sans système de climatisation
	pour véhicules sans direction assistée

 <b>BM</b>	Modèle type
<b>...A</b>	Courant de charge de l'alternateur (A)
<b>...x</b>	Nombre de pièces nécessaires
<b>FAN</b>	Ventilateurs
<b>HYDP</b>	Pompe hydraulique
<b>MY ...</b>	
<b>OE ...</b>	pour numéro OE
<b>ORGA ...</b>	N° d'organisation à partir de N° d'organisation jusqu'à
<b>TURBOC</b>	Turbocompresseur
<b>WP</b>	Pompe à eau
<b>Ø ... mm</b>	Diamètre [mm]

**ALFA ROMEO**
**75 (162B\_)**

1.6; 1.6 Cat; 1.8; 1.8 Turbo; 1.8 Turbo i.e.; 2.0; 2.0 T.S.; 2.0 T.S Cat	05.85-02.92	AR 06100; AR 06134; AR 06158; AR 06166; AR 06168; AR 06202; AR 06212; AR 06224; AR 61101; AR 61102; AR 61201; (81-114kW)			FB 13X1100	42
--	-------------	--	--	--	------------	----

**155 (167\_)**

2.0 16V Turbo Q4	01.92-12.97	AR 67203; (137-140kW)		A/C	FB 13X750	43
------------------	-------------	-----------------------	--	-----	-----------	----

**159 (939\_, 939\_)**

1.8 TBi; 1.9 JTDM 16V; 1.9 JTDM 8V; 2.0 JTDM	09.05-12.12	844 A2.000; 937 A7.000; 937 A8.000; 939 A1.000; 939 A2.000; 939 A8.000; 939 B1.000; 939 B3.000; 939 B4.000; (85-147kW)			534 0610 10	40
--	-------------	--	--	--	-------------	----

**164 (164\_)**

3.0; 3.0 V6	06.87-09.92	AR 06410; AR 06412; (135-141kW)		→03.90, A/C	FB 5PK675	44
-------------	-------------	---------------------------------	--	-------------	-----------	----

**BRERA (939\_)**

1.8 TBi; 2.0 JTDM	03.08-06.10	844 A2.000; 939 B1.000; 939 B3.000; (120-147kW)			534 0610 10	40
-------------------	-------------	---	--	--	-------------	----

**GIULIETTA (940\_)**

1.6 JTDM; 2.0 JTDM	04.10-	940 A3.000; 940 A4.000; 940 A5.000; 940 A7.000; 940 B4.000; 940 B5.000; 940 B9.000; 940 C1.000; 940 C3.000; 940 C5.000; (77-129kW)			534 0610 10	40
--------------------	--------	--	--	--	-------------	----

**MITO (955\_)**

1.6 JTDM	09.08-	198 A2.000; 955 A3.000; 955 A4.000; (85-88kW)			534 0610 10	40
----------	--------	---	--	--	-------------	----

**SPIDER (939\_)**

1.8 TBi; 2.0 JTDM	04.09-06.10	844 A2.000; 939 B1.000; 939 B3.000; (120-147kW)			534 0610 10	40
-------------------	-------------	---	--	--	-------------	----

**AUDI**
**80 (8C2, B4, 8C5, B4)**

2.3 E; 2.3 E quattro	09.91-01.96	NG; (98kW)		A/C	FB 11.2X866	42
RS2 quattro	03.94-05.95	ADU; (232kW)		A/C	FB 13X915	43

**80 (81, 85, B2)**

1.3	09.78-07.81	FZ; (44kW)		→8192300000	FB 10X690	41
-----	-------------	------------	--	-------------	-----------	----

**80 (89, 89Q, 8A, B3)**

1.6 D; 1.6 TD	09.86-08.91	JK; RA; SB; (40-59kW)		A/C	FB 10X715	42
2.3 quattro	10.87-07.89	NG; (98kW)		A/C	FB 11.2X866	42
					FB 13X915	43

**90 (89, 89Q, 8A, B3)**

2.0; 2.2 E; 2.2 E quattro; 2.3 E; 2.3 E 20V; 2.3 E 20V quattro; 2.3 E quattro	04.87-09.91	7A; KV; NG; PS; (85-125kW)		A/C	FB 11.2X866	42
					FB 13X915	43

**100 (44, 44Q, C3, 44, 44Q, C3)**

1.8; 1.8 Cat; 1.8 Cat quattro; 1.8 quattro; 2.0; 2.0 Cat; 2.0 D; 2.0 D Turbo; 2.0 E; 2.0 E Cat; 2.0 TD; 2.1; 2.2; 2.2 Cat; 2.2 Cat quattro; 2.2 E quattro; 2.2 E Turbo quattro; 2.2 quattro; 2.2 Turbo; 2.2 Turbo quattro; 2.3; 2.3 E; 2.3 E quattro; 2.3 quattro	08.82-11.90	4B; CN; DE; DR; DS; HX; JW; KP; KU; KZ; MC; NC; NF; NP; PH; PX; RS; RT; SH; SL; WC; WU; (51-121kW)		A/C	FB 13X915	43
---	-------------	--	--	-----	-----------	----

**200 (44, 44Q, 44, 44Q)**

2.2 Turbo; 2.2 Turbo quattro	09.83-12.91	1B; 2B; MC; (121-147kW)		A/C	FB 13X915	43
------------------------------	-------------	-------------------------	--	-----	-----------	----

**A4 (8K2, B8, 8K5, B8)**

2.0 TDI	11.07-12.15	CAGB; CJCB; CSUB; (100kW)		CJCB, A/C	FB 6PK1264	44
2.0 TDI	11.07-12.15	CAGA; CJCA; CMEA; CMFA; (105kW)		CJCA, CMFA, A/C	FB 6PK1264	44
2.0 TDI	04.08-12.15	CAGB; CAHB; CGLD; CJCB; CNHC; CSUB; (100-120kW)		CGLD, A/C	FB 6PK1264	44
2.0 TDI	06.08-12.15	CAGC; CJCC; (88kW)		CJCC, A/C	FB 6PK1264	44
2.0 TDI; 2.0 TDI quattro	11.11-12.15	CGLC; CJCD; CMFB; CMGB; CSUA; (110-130kW)		A/C	FB 6PK1264	44
2.0 TDI quattro	04.08-12.15	CAGA; CJCA; (105kW)		CJCA, A/C	FB 6PK1264	44

**A4 Allroad (8KH, B8)**

2.0 TDI quattro	04.09-05.16	CAHB; CGLD; CNHC; (120kW)		CGLD, A/C	FB 6PK1264	44
2.0 TDI quattro	09.09-05.16	CAGB; CJCB; CSUB; (100kW)		CJCB, A/C	FB 6PK1264	44
2.0 TDI quattro	09.09-05.16	CAGA; CJCA; (105kW)		CJCA, A/C	FB 6PK1264	44
2.0 TDI quattro	11.11-05.16	CGLC; (130kW)		A/C	FB 6PK1264	44

**AUDI**
**A5 (8TA, 8T3)**

2.0 TDI; 2.0 TDI quattro	10.11-01.17	CGLC; (130kW)		A/C	FB 6PK1264	44
--------------------------	-------------	---------------	--	-----	------------	----

**A5 Décapotable (8F7)**

2.0 TDI; 2.0 TDI quattro	10.11-01.17	CGLC; (130kW)		A/C	FB 6PK1264	44
--------------------------	-------------	---------------	--	-----	------------	----

**A6 (4G5, 4GD, C7, 4G2, 4GC, C7)**

2.0 TDI	03.11-	CGLC; CGLD; CGLE; CMGB; CSUE; (100-130kW)		A/C	FB 6PK1264	44
---------	--------	---	--	-----	------------	----

**CABRIOLET (8G7, B4)**

2.3 E	05.91-07.94	NG; (98kW)			FB 11.2X866	42
-------	-------------	------------	--	--	-------------	----

**COUPE (89, 8B)**

2.2 quattro; 2.3 20V quattro	11.88-12.96	7A; KV; (100-123kW)		A/C	FB 11.2X866	42
------------------------------	-------------	---------------------	--	-----	-------------	----

2.3	10.88-12.96	NG; (98-100kW)		→8B-N-003 457,  A/C	FB 11.2X866	42
-----	-------------	----------------	--	---------------------	-------------	----

2.3	10.88-12.96	NG; (98-100kW)		A/C	FB 13X915	43
-----	-------------	----------------	--	-----	-----------	----

2.3 quattro	11.88-12.96	NG; (98-100kW)		→8B-N-003 901,  A/C	FB 11.2X866	42
-------------	-------------	----------------	--	---------------------	-------------	----

2.3 quattro	11.88-12.96	NG; (98-100kW)		A/C	FB 13X915	43
-------------	-------------	----------------	--	-----	-----------	----

**Q5 (8RB)**

2.0 TDI quattro	11.08-	CAHB; CGLA; CGLD; CNHC; (120kW)		CGLA, CGLD,  A/C	FB 6PK1264	44
-----------------	--------	---------------------------------	--	------------------	------------	----

2.0 TDI quattro	08.09-	CAGB; CJCB; CSUB; (100kW)		CJCB,  A/C	FB 6PK1264	44
-----------------	--------	---------------------------	--	------------	------------	----

2.0 TDI quattro	08.09-	CAGA; CJCA; (105kW)		CJCA,  A/C	FB 6PK1264	44
-----------------	--------	---------------------	--	------------	------------	----

2.0 TDI quattro	06.12-	CGLC; CMGB; (130kW)		A/C	FB 6PK1264	44
-----------------	--------	---------------------	--	-----	------------	----

**BMW**
**1 (E82, E88)**

135 i	10.07-12.13	N54 B30 A; N55 B30 A; (225kW)		N55,  A/C	529 0204 10	39
-------	-------------	-------------------------------	--	-----------	-------------	----

135 i	03.08-12.13	N55 B30 A; (240kW)		A/C	529 0204 10	39
-------	-------------	--------------------	--	-----	-------------	----

**1 (F21, F20)**

118 d; 118 d xDrive; 120 d; 120 d xDrive; 125 d	03.15-	B47 D20 A; B47 D20 B; (110-165kW)			534 0627 10	40
---	--------	-----------------------------------	--	--	-------------	----

**2 Active Tourer (F45)**

214 d; 216 d; 218 d; 218 i; 220 d; 220 d xDrive; 220 i; 225 i; 225 i xDrive	11.13-	B37 C15 A; B38 A15 A; B47 C20 A; B47 D20 A; B48 A20 A; B48 A20 B; (70-170kW)			532 0804 10	40
---	--------	--	--	--	-------------	----

**2 Décapotable (F23)**

218 d; 220 d; 225 d	03.14-	B47 D20 A; B47 D20 B; (100-165kW)			534 0627 10	40
---------------------	--------	-----------------------------------	--	--	-------------	----

**2 Coupé (F22, F87)**

218 d; 220 d; 220 d xDrive; 225 d	03.14-	B47 D20 A; B47 D20 B; (100-165kW)			534 0627 10	40
-----------------------------------	--------	-----------------------------------	--	--	-------------	----

**2 Gran Tourer (F46)**

214 d; 216 d; 216 i; 218 d; 218 i; 220 d; 220 d xDrive; 220 i	07.14-	B37 C15 A; B38 A15 A; B47 C20 A; B48 A20 A; (70-141kW)			532 0804 10	40
---	--------	--	--	--	-------------	----

**3 (E30, E30, E30)**

320 i; 323 i	09.82-12.91	M20 B20 (206EB); M20 B23 (236EC); (92-102kW)		WP, FAN,  06.83→	FB 10X965	42
--------------	-------------	--	--	------------------	-----------	----

320 i; 323 i; 325 e 2.7; 325 i; 325 i X	09.83-10.93	M20 B20 (206KA); M20 B23 (236EC); M20 B25 (256E1); M20 B25 (256E2); M20 B25 (256EX); M20 B25 (256K1); M20 B27 (276KA); M20 B27 (276KB); (90-126kW)		WP, FAN	FB 10X965	42
---	-------------	--	--	---------	-----------	----

325 i	12.85-12.87	M20 B25 (256E2); (126kW)			FB 10X965	42
-------	-------------	--------------------------	--	--	-----------	----

**3 (E46, E46, E46)**

320 d; 320 td	09.01-02.05	M47 D20 (204D4); (110kW)		WP,  →09.02	FB 6PK2090	44
---------------	-------------	--------------------------	--	-------------	------------	----

**3 (E90, E91)**

335 i; 335 i xDrive; 335 xi	03.06-05.12	N54 B30 A; N55 B30 A; (220-225kW)		N55,  A/C	529 0204 10	39
-----------------------------	-------------	-----------------------------------	--	-----------	-------------	----

**3 Coupé (E92)**

335 i; 335 i xDrive; 335 xi	11.05-12.13	N54 B30 A; N55 B30 A; (225kW)		N55,  A/C	529 0204 10	39
-----------------------------	-------------	-------------------------------	--	-----------	-------------	----

**3 Décapotable (E93)**

335 i	05.06-10.13	N54 B30 A; N54 B30 B; N55 B30 A; (225kW)		N55,  A/C	529 0204 10	39
-------	-------------	--	--	-----------	-------------	----

**3 (F34, F31, F30, F80)**

318 d; 318 d xDrive; 320 d; 320 d Efficient Dynamics; 320 d xDrive; 325 d	04.11-	B47 D20 A; B47 D20 B; N47 D20 C; (110-165kW)			534 0627 10	40
---	--------	--	--	--	-------------	----

**4 (F32, F82, F33, F83)**

418 d; 420 d; 420 d xDrive; 425 d	03.15-	B47 D20 A; B47 D20 B; (110-165kW)			534 0627 10	40
-----------------------------------	--------	-----------------------------------	--	--	-------------	----

**4 Gran Coupe (F36)**

418 d; 420 d; 420 d xDrive; 425 d	03.14-	B47 D20 A; B47 D20 B; N47 D20 C; (100-165kW)			534 0627 10	40
-----------------------------------	--------	--	--	--	-------------	----

**BMW**

<b>5 (E28)</b>						
520 i	06.81-12.87	M20 B20 (206EA); (92kW)		WP, FAN,  05.83→	<b>FB 10X965</b>	42
520 i; 525 e	12.84-12.87	M20 B20 (206KA); M20 B27 (276KB); (95kW)		WP, FAN	<b>FB 10X965</b>	42
525 e	09.81-12.87	M20 B27 (276EA); M20 B27 (276EB); M20 B27 (276KA); M20 B27 (276KB); (90-92kW)		WP, FAN,  09.83→	<b>FB 10X965</b>	42
<b>5 (F10, F11)</b>						
518 d; 520 d; 520 d xDrive	01.09-10.16	B47 D20 A; N47 D20 C; (100-140kW)			<b>534 0627 10</b>	40
535 i; 535 i xDrive	01.09-10.16	N55 B30 A; (225-240kW)		pour véhicules avec direction active	<b>FB 8PK1478</b>	45
<b>5 Gran Turismo (F07)</b>						
535 i; 535 i xDrive	01.09-	N55 B30 A; (225kW)		pour véhicules avec direction active	<b>FB 8PK1478</b>	45
<b>6 (F13, F12)</b>						
640 i; 640 i xDrive	11.10-	N55 B30 A; (235kW)		pour véhicules avec direction active	<b>FB 8PK1478</b>	45
<b>6 Gran Coupe (F06)</b>						
640 i; 640 i xDrive	09.11-	N55 B30 A; (235kW)		pour véhicules avec direction active	<b>FB 8PK1478</b>	45
<b>7 (F01, F02, F03, F04)</b>						
740 i, Li	07.12-12.15	N55 B30 A; (235kW)		pour véhicules avec direction active	<b>FB 8PK1478</b>	45
<b>X1 (F48)</b>						
sDrive 18 d; sDrive 20 i; xDrive 20 d; xDrive 20 i; xDrive 25 d; xDrive 25 i	11.14-	B46 A20 B; B47 C20 A; B47 C20 B; B48 A20 A; B48 A20 B; (100-170kW)			<b>532 0804 10</b>	40
<b>X3 (F25)</b>						
sDrive 18 d; xDrive 20 d	02.14-	B47 D20 A; (110-140kW)			<b>534 0627 10</b>	40
<b>X4 (F26)</b>						
xDrive 20 d	07.13-	B47 D20 A; (120-140kW)			<b>534 0627 10</b>	40
xDrive 35 i	06.13-	N55 B30 A; (225kW)		pour véhicules avec direction active	<b>FB 8PK1478</b>	45
<b>X5 (E70)</b>						
xDrive 35 i	09.10-06.13	N55 B30 A; (225-235kW)		A/C	<b>FB 8PK1478</b>	45
<b>X5 (F15, F85)</b>						
sDrive 25 d; xDrive 25 d	07.15-	B47 D20 B; (170kW)			<b>534 0627 10</b>	40
xDrive 35 i	11.13-	N55 B30 A; (225-240kW)		pour véhicules avec direction active	<b>FB 8PK1478</b>	45
<b>X6 (E71, E72)</b>						
xDrive 35 i	06.07-06.14	N54 B30 A; N55 B30 A; (225-235kW)		A/C	<b>FB 8PK1478</b>	45
<b>X6 (F16, F86)</b>						
xDrive 35 i	12.14-	N55 B30 A; (225-240kW)		pour véhicules avec direction active	<b>FB 8PK1478</b>	45
<b>Z1 Roadster</b>						
2.5	06.88-06.91	M20 B25 (256K1); (125kW)		WP, FAN	<b>FB 10X965</b>	42

**CADILLAC**

<b>BLS / BLS Wagon</b>						
1.9 D	04.06-	Z19DTH; Z 19 DTR; (110-132kW)		→71111927	<b>534 0610 10</b>	40

**CHEVROLET**

<b>AVEO (T250, T255, T250, T255)</b>						
1.4	04.08-	F14D4; LDT; (74kW)		A/C	<b>FB 5PK1570</b>	44
<b>MATIZ (M200, M250)</b>						
0.8; 0.8 LPG	03.05-	F8CV; (38kW)		A/C	<b>FB 4PK910</b>	44
<b>SPARK</b>						
0.8	05.05-	F8CV; (37kW)		A/C	<b>FB 4PK910</b>	44
<b>SUBURBAN (GMT 900)</b>						
5.3 Flex-Fuel 4WD	01.07-	LMG; (228kW)		105A	<b>FB 6PK2345</b>	45
<b>TAHOE (B2W)</b>						
4.8 V8	12.99-12.06	LR4; (206kW)		105A	<b>FB 6PK2345</b>	45

**CITROEN**

<b>BERLINGO (B9, B9, B9)</b>						
1.6 BlueHDi 100; 1.6 BlueHDi 100 4x4; 1.6 BlueHDi 120	12.14-	BHY (DV6FD); BHZ (DV6FC); (73-88kW)		pas pour générateur de démarrage	<b>535 0308 10</b>	41
1.6 HDi 75 / BlueHDi 75	04.08-	9HN (DV6ETED); BHW (DV6FE); (55kW)		pas pour générateur de démarrage DV6FE	<b>535 0308 10</b>	41





## CITROËN

## BX (XB\_, XB\_)

1.8 D; 19 D; TRD Turbo	09.83-12.94	161 (XUD7); 162 (XUD9); A8A (XUD7TE); AJZ (XUD7TE); D9A (XUD9); D9B (XUD9A/U); DJZ (XUD9Y); (44-66kW)		M12	532 0424 10	40
				ORGA 4071→, →ORGA 4356, A/C	FB 4PK1230	43
1.9 D; 1.9 RD 4x4	01.87-01.92	D9B (XUD9A/L); (52kW)		M12	532 0424 10	40
14	01.89-02.93	K1H (TU3A); KDY (TU3M); (47-55kW)		HYDP	FB 10X715	42
18 D	10.85-09.93	161A (XUD7); (44kW)		M12	532 0424 10	40
				ORGA 4071→, →ORGA 4357, A/C	FB 4PK1230	43

## C3 II

1.6 BlueHDi 100; 1.6 BlueHDi 75	07.14-	BHW (DV6FE); BHY (DV6FD); (55-73kW)		pas pour générateur de démarrage	535 0308 10	41
---------------------------------	--------	-------------------------------------	--	----------------------------------	-------------	----

## C3 Picasso

1.6 BlueHDi 100	01.15-	BHY (DV6FD); (73kW)		pas pour générateur de démarrage	535 0308 10	41
-----------------	--------	---------------------	--	----------------------------------	-------------	----

## C4 II (B7)

1.6 BlueHDi 100; 1.6 BlueHDi 115; 1.6 BlueHDi 120	07.14-	BHX (DV6FC); BHY (DV6FD); BHZ (DV6FC); (73-88kW)		pas pour générateur de démarrage	535 0308 10	41
--	--------	--	--	----------------------------------	-------------	----

## C4 AIRCROSS

1.8 HDi 150; 1.8 HDi 150 AWC	04.12-	4N13; (110kW)		WP	FB 3EPK863	43
------------------------------	--------	---------------	--	----	------------	----

## C4 CACTUS

1.6 BlueHDi 100	09.14-	BHY (DV6FD); (73kW)		pas pour générateur de démarrage	535 0308 10	41
-----------------	--------	---------------------	--	----------------------------------	-------------	----

## C4 Picasso II

1.6 BlueHDi 100; 1.6 BlueHDi 120; 1.6 HDi / BlueHDi 115	02.13-	9HC (DV6C); BHX (DV6FC); BHY (DV6FD); BHZ (DV6FC); (73-88kW)		pas pour générateur de démarrage	535 0308 10	41
--	--------	--	--	----------------------------------	-------------	----

## C5 (RE\_, RC\_, RD\_, TD\_)

2.2 HDi; 2.2 HDi 165	04.06-	4HP (DW12BTED4); 4HR (DW12BTED4); 4HT (DW12BTED4); (120-125kW)			544 0112 10	41
----------------------	--------	--	--	--	-------------	----

## C6 (TD\_)

2.2 HDi	06.06-	4HP (DW12BTED4); 4HT (DW12BTED4); (120-125kW)			544 0112 10	41
---------	--------	---	--	--	-------------	----

## C8 (EA\_, EB\_)

2.2 HDi	06.06-	4HP (DW12BTED4); 4HR (DW12BTED4); 4HT (DW12BTED4); (120-125kW)			544 0112 10	41
---------	--------	--	--	--	-------------	----

## C15 (VD\_)

1.0; 1.1; 1.4; 1.4 E	10.84-12.97	109K; 150D (XY7); E1A; K1H (TU3A); TU9; XV8; (33-49kW)		05.88→	FB 10X715	42
----------------------	-------------	--	--	--------	-----------	----

1.1; 1.1 i; 1.4 E; 1.4 i	07.87-12.96	H1A; HDZ (TU1M); K3A; KDY (TU3FM); KDY (TU3M); (40-55kW)			FB 10X715	42
--------------------------	-------------	--	--	--	-----------	----

## C-CROSSER (EP\_)

2.2 HDi	02.07-	4HN (DW12MTED4); (115kW)			544 0112 10	41
---------	--------	--------------------------	--	--	-------------	----

## C-ELYSEE

1.6 BlueHDi 100	11.14-	BHY (DV6FD); (73kW)		pas pour générateur de démarrage	535 0308 10	41
-----------------	--------	---------------------	--	----------------------------------	-------------	----

## DS3

1.6 BlueHDi 100; 1.6 BlueHDi 115; 1.6 BlueHDi 120; 1.6 BlueHDi 75; 1.6 HDi 115	10.13-07.15	BHW (DV6FE); BHX (DV6FC); BHY (DV6FD); BHZ (DV6FC); (55-88kW)		pas pour générateur de démarrage	535 0308 10	41
--	-------------	---	--	----------------------------------	-------------	----

## DS4

1.6 BlueHDi 115; 1.6 BlueHDi 120	07.14-07.15	BHX (DV6FC); BHZ (DV6FC); (85-88kW)		pas pour générateur de démarrage	535 0308 10	41
----------------------------------	-------------	-------------------------------------	--	----------------------------------	-------------	----

## DS5

1.6 BlueHDi 120; 1.6 HDi	11.13-07.15	BHX (DV6FC); BHZ (DV6FC); (85-88kW)		pas pour générateur de démarrage	535 0308 10	41
--------------------------	-------------	-------------------------------------	--	----------------------------------	-------------	----

## JUMPER I (230L, 230P, 230)

2.0; 2.0 4x4	02.94-04.02	RFW (XU10J2U); (80kW)			FB 10X715	42
--------------	-------------	-----------------------	--	--	-----------	----

				A/C	FB 6PK1093	44
--	--	--	--	-----	------------	----

2.0	03.94-04.02	RFW (XU10J2U); (80kW)		→12.96	FB 10X715	42
-----	-------------	-----------------------	--	--------	-----------	----

				A/C	FB 6PK1093	44
--	--	--	--	-----	------------	----

## JUMPER II (244, 244, Z\_)

2.0; 2.0 bivalent	04.02-	XU10J2; (81kW)		A/C	FB 6PK1093	44
-------------------	--------	----------------	--	-----	------------	----

## JUMPY / JUMPY Camionnette

1.6 BlueHDi 115; 1.6 BlueHDi 95	04.16-	BHS (DV6FDU); BHV (DV6FDU); BHX (DV6FCU); (70-85kW)		pas pour générateur de démarrage	535 0308 10	41
---------------------------------	--------	---	--	----------------------------------	-------------	----

## SPACETOURER

1.6 BlueHDi 115; 1.6 BlueHDi 95	04.16-	BHV (DV6FDU); BHX (DV6FCU); (70-85kW)		pas pour générateur de démarrage	535 0308 10	41
---------------------------------	--------	---------------------------------------	--	----------------------------------	-------------	----

## VISA

17 D	04.84-03.91	161A (XUD7); (44kW)		M12	532 0424 10	40
------	-------------	---------------------	--	-----	-------------	----

## XM (Y3, Y3, Y4, Y4)

2.1 D12; 2.1 D 12V; 2.1 TD 12V	05.89-10.00	P8A (XUD11ATE); P8C (XUD11BTE); P9A (XUD11A); PHZ (XUD11ATE); PJZ (XUD11ATE); (60-80kW)		A/C,  AUTOM	FB 5PK768	44
--------------------------------	-------------	---	--	-------------	-----------	----



**CITROËN**

<b>ZX (N2, N2)</b>						
1.6 i; 1.8 i	03.91-10.97	BDY (XU5M); BFZ (XU5JP); LFZ (XU7JP); (65-74kW)		<b>A/C</b>	<b>FB 6PK1093</b>	44

**DACIA**

<b>LOGAN (LS_)</b>						
1.2 16V; 1.2 16V LPG	02.06-	D4F 732; D4F 734; (55kW)		<b>A/C</b> ,  06.09→, →09.12,	<b>529 0280 10</b>	39

<b>SANDERO</b>						
1.2 16V; 1.2 16V LPG	11.08-	D4F 732; (55kW)		<b>A/C</b> ,  →09.12,	<b>529 0280 10</b>	39

**DAIHATSU**

<b>WILDCAT/ROCKY (F70, F75)</b>						
2.8 D; 2.8 TD	02.85-04.87	DL; DL 50; (54-65kW)			<b>FB 13X775</b>	43

**DAIMLER**

<b>2.8 - 5.3</b>						
Double Six 5.3; Double Six H.E. 5.3	05.75-02.93	7P; V 12 (75-79); V 12 (82-90); V 12 (90-93); (194-217kW)		WP,	<b>FB 13X1075</b>	42

**DS**

<b>DS 3 / DS 3 Décapotable</b>						
1.6 BlueHDi 100; 1.6 BlueHDi 120; 1.6 BlueHDi 75	04.15-	BHW (DV6FE); BHY (DV6FD); BHZ (DV6FC); (55-88kW)		pas pour générateur de démarrage	<b>535 0308 10</b>	41

**FIAT**

<b>BRAVO I / BRAVA (182_, 182_)</b>						
1.2 16V 80	12.98-12.02	182 B2.000; 188 A5.000; (59-60kW)		<b>A/C</b>	<b>FB 5PK1585</b>	44

<b>BRAVO II (198_)</b>						
1.6 D Multijet; 2.0 D Multijet	09.07-	198 A2.000; 198 A3.000; 198 A5.000; 198 A6.000; 198 A8.000; 844 A2.000; 844 A3.000; 955 A4.000; (66-121kW)		→12.09	<b>534 0610 10</b>	40
1.9 D Multijet	04.07-	937 A5.000; (110kW)			<b>534 0610 10</b>	40

<b>COUPE (175_)</b>						
2.0 16V; 2.0 16V Turbo	11.93-08.96	175 A1.000; 836 A3.000; (102-140kW)		<b>A/C</b>	<b>FB 13X750</b>	43

<b>CROMA (154_)</b>						
2000 16V; 2000 i.e. Turbo	06.87-08.96	154 C4.046; 154 E1.000; 834 C.146; (101-110kW)		<b>A/C</b>	<b>FB 13X750</b>	43
2000 CHT	12.85-02.89	154 A1.000; (66kW)		0216251→, <b>A/C</b>	<b>FB 13X750</b>	43
				0216250→, <b>A/C</b>	<b>FB 13X775</b>	43
2000 i.e.	03.86-09.90	834 B.048; (83kW)		0216251→, <b>A/C</b>	<b>FB 13X750</b>	43
				→0216250, <b>A/C</b>	<b>FB 13X775</b>	43
2500 D	12.85-12.89	8144.67; (55kW)		HYDP	<b>FB 10X715</b>	42

<b>CROMA (194_)</b>						
1.9 D Multijet	06.05-	939 A1.000; 939 A2.000; 939 A7.000; 939 A8.000; (85-110kW)		→12.09	<b>534 0610 10</b>	40

<b>DOBLO (263_, 263_, 263_)</b>						
1.6 D Multijet; 2.0 D Multijet	02.10-	198 A3.000; 263 A1.000; 263 A3.000; 263 A4.000; 263 A5.000; 263 A8.000; 263 A9.000; (66-99kW)			<b>534 0610 10</b>	40
1.6 D Multijet	03.15-	263 A3.000; 263 A7.000; 940 C1.000; (70-88kW)			<b>534 0610 10</b>	40

<b>DUCATO (250_, 290_, 250_, 290_, 250_, 290_)</b>						
115 Multijet 2,0 D	06.11-	250 A1.000; 250 A2.000; (85kW)			<b>534 0610 10</b>	40

<b>DUCATO Camion plate-forme/Châssis (280_)</b>						
1.9 D	01.88-08.90	149 B1.000; (52kW)		→0889988	<b>FB 13X915</b>	43

<b>FREEMONT (345_)</b>						
2.0 JTD; 2.0 JTD 4x4	08.11-	939 B5.000; 940 A5.000; (100-125kW)			<b>534 0610 10</b>	40

<b>LINEA (323_)</b>						
1.6 D Multijet	06.09-	198 A3.000; (77kW)			<b>534 0610 10</b>	40

<b>PUNTO / GRANDE PUNTO (199_, 199_)</b>						
1.6 D Multijet; 1.9 D Multijet	10.05-02.12	199 A5.000; 939 A1.000; 939 A7.000; 955 A3.000; (85-96kW)			<b>534 0610 10</b>	40

<b>PUNTO (176_, 176_)</b>						
1.4 GT Turbo; 1.6; 90 1.6	01.94-09.99	176 A4.000; 176 A9.000; 176 B6.000; (65-98kW)			<b>FB 10X690</b>	41

<b>SCUDO Combinato (220_)</b>						
1.6	02.96-12.06	220 A 2.000; (58kW)			<b>FB 10X690</b>	41

<b>SEDICI (FY_)</b>						
1.9 D Multijet; 1.9 D Multijet 4x4	06.06-10.14	D19AA; (88kW)			<b>534 0610 10</b>	40
2.0 D Multijet; 2.0 D Multijet 4x4	06.06-10.14	D20AA; (99kW)		939B3.000	<b>534 0610 10</b>	40



**FIAT**

**SIENA (178\_)**

1.4; 1.4 Cat	04.96-12.09	178 B2.000; 178 B2.016; (51kW)				FB 10X690	41
--------------	-------------	--------------------------------	--	--	--	-----------	----

**STILO (192\_, 192\_)**

1.9 D Multijet; 1.9 JTD	09.03-08.08	192 A5.000; 192 B1.000; 937 A4.000; 937 A5.000; (93-110kW)				534 0610 10	40
-------------------------	-------------	--	--	--	--	-------------	----

**TEMPRA (159\_)**

1.6; 1.6 i.e.	03.90-08.96	159 A3.000; 159 B9.000; (63kW)				FB 10X690	41
---------------	-------------	--------------------------------	--	--	--	-----------	----

1.8 i.e.	03.90-08.96	159 A4.000; 159 A4.046; (77-81kW)			→, A/C	FB 13X750	43
----------	-------------	-----------------------------------	--	--	--------	-----------	----

1.8 i.e.; 2.0 i.e.	10.90-08.96	159 A6.046; 835 C2.000; 835 C4.000; 836 A5.000; (66-83kW)			A/C	FB 13X750	43
--------------------	-------------	---	--	--	-----	-----------	----

**TEMPRA SW (159\_)**

1.8 i.e.	03.90-08.96	159 A4.000; 159 A4.046; (77-81kW)			→, A/C	FB 13X750	43
----------	-------------	-----------------------------------	--	--	--------	-----------	----

1.8 i.e.; 2.0 i.e.	01.91-08.96	159 A6.046; 835 C2.000; 835 C4.000; 836 A5.000; (66-83kW)			A/C	FB 13X750	43
--------------------	-------------	---	--	--	-----	-----------	----

**TIPO (160\_)**

1.4 i.e.; 1.6; 1.6 i.e.	01.88-04.95	149 C2.046; 159 A2.000; 159 A3.046; 160 A1.046; 160 A1.048; 160 A2.000; 836 A4.000; (51-66kW)			→	FB 10X690	41
-------------------------	-------------	---	--	--	---	-----------	----

1.6 i.e.	10.92-04.95	159 A3.048; 835 C1.000; (55kW)			→,	FB 10X690	41
----------	-------------	--------------------------------	--	--	----	-----------	----

1.8 i.e.; 1.8 i.e.; 2.0 16V; 2.0 i.e.; 2.0 i.e. 16V Sport	03.90-10.95	159 A4.000; 159 A5.046; 159 A6.046; 160 A8.046; 835 C2.000; 835 C4.000; 836 A3.000; 836 A5.000; (66-107kW)			A/C	FB 13X750	43
---	-------------	--	--	--	-----	-----------	----

1.8 i.e.	10.90-06.93	159 A4.046; (77kW)			→, A/C	FB 13X750	43
----------	-------------	--------------------	--	--	--------	-----------	----

**ULYSSE (179\_)**

2.2 D Multijet; 2.2 JTD	03.08-06.11	4HP; 4HR; 4HS; 4HT (DW12BTED4); (120-125kW)				544 0112 10	41
-------------------------	-------------	---	--	--	--	-------------	----

**FORD**

**COUGAR (EC\_)**

2.0 16V	08.98-12.01	EDBA; EDBB; EDBC; EDBD; (96kW)				529 0281 10	40
---------	-------------	--------------------------------	--	--	--	-------------	----

**ECONOVAN (KBA, KCA)**

2.0 D	03.86-03.92	RF; (41kW)				FB 13X1100	42
-------	-------------	------------	--	--	--	------------	----

**ESCORT '81 Courier (AVA)**

1.3	03.81-02.86	JPA; (51kW)			→,	FB 11.9X793	42
-----	-------------	-------------	--	--	----	-------------	----

**ESCORT '86 Courier (AVF)**

1.1	05.86-07.90	GSG; (37kW)			→	FB 11.9X793	42
-----	-------------	-------------	--	--	---	-------------	----

1.4 i	02.86-07.90	F6B; F6D; FUC; (54kW)			→, A/C	FB 11.9X793	42
-------	-------------	-----------------------	--	--	--------	-------------	----

**ESCORT '91 Courier (AVL)**

1.3	07.90-12.94	JBD; (46kW)				FB 11.9X793	42
-----	-------------	-------------	--	--	--	-------------	----

**ESCORT III (GAA) / ESCORT III Break (AWA)**

1.3; 1.6	09.80-12.85	JPA; LP1; LPA; (51-58kW)			→,	FB 11.9X793	42
----------	-------------	--------------------------	--	--	----	-------------	----

1.6; 1.6 i	09.80-12.85	L4B; LUA; (66-71kW)				FB 11.9X793	42
------------	-------------	---------------------	--	--	--	-------------	----

1.6 XR3i	10.82-12.85	LR1; LRA; (77kW)			→	FB 11.9X793	42
----------	-------------	------------------	--	--	---	-------------	----

RS 1600i	05.82-12.85	LUAE; (85kW)			→	FB 11.9X793	42
----------	-------------	--------------	--	--	---	-------------	----

**ESCORT IV (GAF, AWF, ABFT)**

1.3	07.88-10.90	JBA; (46kW)			→	FB 11.9X793	42
-----	-------------	-------------	--	--	---	-------------	----

**ESCORT VII (GAL, AAL, ABL, GAL, AFL)**

1.3	01.95-10.98	J4B; J6A; (44kW)			→	FB 11.9X793	42
-----	-------------	------------------	--	--	---	-------------	----

1.3	01.95-02.99	J4B; J6A; (44kW)				FB 11.9X793	42
-----	-------------	------------------	--	--	--	-------------	----

**COURIER Camionnette (F3L, F5L)**

1.3	09.91-02.96	J6B; (44kW)			→	FB 11.9X793	42
-----	-------------	-------------	--	--	---	-------------	----

**COURIER Camionnette (J5\_, J3\_)**

1.8 D	02.96-04.02	RTK; (44kW)			A/C,	FB 5PK675	44
-------	-------------	-------------	--	--	------	-----------	----

**FIESTA Camionnette (JV\_)**

D 1.8	05.98-04.02	RTJ; RTK; (44kW)				FB 5PK675	44
-------	-------------	------------------	--	--	--	-----------	----

**FIESTA II (FBD)**

1.4	10.85-11.89	FUB; (55kW)				FB 10X690	41
-----	-------------	-------------	--	--	--	-----------	----

**FIESTA III (GFJ)**

1.3	03.89-12.95	JBB; JBC; (44kW)			→, →05.92	FB 11.9X793	42
-----	-------------	------------------	--	--	-----------	-------------	----

1.3 Cat	05.91-01.97	J6B; (44kW)			→	FB 11.9X793	42
---------	-------------	-------------	--	--	---	-------------	----

1.4; 1.6	01.89-12.95	F6E; LUH; (52-66kW)				FB 10X690	41
----------	-------------	---------------------	--	--	--	-----------	----

**FIESTA IV (JA\_, JB\_)**

1.8 D; 1.8 DI	08.95-01.02	RTJ; RTK; RTN; RTP; RTQ; (44-55kW)				FB 5PK675	44
---------------	-------------	------------------------------------	--	--	--	-----------	----



**FORD**

<b>FOCUS (DNW, DAW, DBW, DFW)</b>						
1.8 16V; 2.0 16V	10.98-11.04	Eddb; EDDC; EDDD; EDDF; EYDB; EYDC; EYDD; EYDE; EYDF; EYDG; EYDI; EYDJ; EYDL; (85-96kW)		→06.01,	529 0281 10	40
<b>GALAXY (WA6)</b>						
2.2 TDCi	03.08-12.12	Q4BA; Q4WA; (129kW)			544 0112 10	41
<b>GRANADA (GGTL, GGFL)</b>						
3.0	01.72-02.76	EV 30 H; (101kW)			FB 13X915	43
<b>GRANADA (GU)</b>						
2.1 D	08.77-08.82	WTA; (46kW)		Pompe à vide,  →06.81	FB 10X690	41
<b>GRANADA Coupé (GGCL)</b>						
2.3; 2.6	01.72-02.76	UY; YY; (79-92kW)		09.75→	FB 13X1225	42
<b>GRANADA Turnier (GGNL)</b>						
3.0	01.72-02.76	EV 30 H; (101kW)			FB 13X915	43
<b>MONDEO II (BFP, BNP, BAP)</b>						
1.6 i; 1.8 i; 2.0 i	08.96-09.00	L1J; NGA; NGB; NGC; NGD; RKB; RKF; RKH; RKJ; RKK; (66-96kW)		05.98→,	529 0281 10	40
1.6 i 16V	05.98-09.00	L1L; L1N; L1Q; (70kW)			529 0281 10	40
<b>MONDEO IV (BA7, BA7, BA7)</b>						
2.2 TDCi	03.08-10.10	Q4BA; (129kW)			544 0112 10	41
<b>ORION II (AFF)</b>						
1.6 i	03.86-07.90	LRB; (77kW)		→12.88	FB 11.5X755	42
				12.88→	FB 11.9X793	42
<b>PUMA (EC_)</b>						
1.6 16V	08.00-06.02	L1W; (76kW)			FB 6PK1755	44
<b>SCORPIO II (GNR, GGR, GFR, GGR)</b>						
2.0 i; 2.0 i 16V; 2.3 i 16V	10.94-08.98	N3A; NSD; Y5A; (85-108kW)		WP,	FB 6PK1755	44
<b>SIERRA (GBC, BNC)</b>						
2.0	08.82-10.84	NYT; (66kW)			FB 13X1225	42
2.3; 2.8 i 4x4; 2.8 XR4i	08.82-12.86	PRG; PRT; YYT; (84-110kW)		→10.84	FB 13X1225	42
<b>TRANSIT V (FD_ , FB_ , FS_ , FZ_ , FC_ , FA_ , FM_ , FN_ )</b>						
2.3 16V; 2.3 16V [RWD]	08.00-05.06	E5FA; E5FC; (107kW)			FB 6PK1955	44
<b>TRANSIT Camion plate-forme/Châssis (V_ )</b>						
1.6	11.77-10.86	B; (48kW)		11.84→	FB 13X915	43

**HONDA**

<b>ACCORD I (SJ, SY, SJ, SY)</b>						
1.6 L/EX	01.78-09.83	EG; EL; (59kW)			FB 10X690	41
<b>ACCORD II (AC, AD, AC, AD)</b>						
1.8 EX	09.83-10.85	ET1; (74kW)			FB 4PK910	44
<b>ACCORD III (CA, CA)</b>						
2.0 EX; 2.0 EXi	11.85-12.89	A20A1; A20A2; A20A3; A20A4; (75-90kW)			FB 4PK910	44
2.0 i 16V	01.87-12.87	B20A2; (101kW)			FB 3PK798	43
2.0 i 16V	10.87-12.89	B20A8; (98kW)		WP	FB 3PK798	43
<b>CIVIC IX (FK, FK)</b>						
1.6 i-DTEC	02.13-	N16A1; (88kW)			534 0586 10	40
<b>CR-V IV (RM_)</b>						
1.6 i-DTEC; 1.6 i-DTEC 4WD	10.13-	N16A1; N16A4; (88-118kW)			534 0586 10	40
<b>PRELUDE III (BA)</b>						
2.0 i EX 16V	04.86-12.87	B20A1; (101kW)		WP	FB 3PK798	43
<b>QUINTET (SU)</b>						
1.6 EX	02.80-12.84	EL; (59kW)		→06.81	FB 10X965	42

**HYUNDAI**

<b>ACCENT I / EXCEL I (X-3, X-3)</b>						
1.3; 1.3 i 12V; 1.5 i 12V; 1.5 i 16V	10.94-01.00	G4EH; G4EK; G4ER; (44-73kW)			FB 4PK611	43
<b>ACCENT II (LC, LC)</b>						
1.3; 1.5	01.00-11.05	G4EA; G4EB; G4EC-G; G4EH; (55-75kW)			FB 4PK611	43
1.6	12.02-11.05	G4ED-G; (77kW)			FB 13X675	43
<b>ATOS / ATOS PRIME / AMICA (MX, MX)</b>						
1.0 i; 1.1	02.98-05.05	G4HC; G4HD; (40-43kW)			FB 13X775	43
1.0 i	08.99-	G4HC; (40kW)		→08.02	FB 13X775	43
<b>ELANTRA A trois volumes (MD, UD)</b>						
1.6 CRDi	02.11-12.15	D4FB; (94kW)		START/STOP,	529 0195 10	39





## HYUNDAI

### GETZ (TB)

1.3; 1.3 i	09.02-09.05	G4EA; (60-63kW)			FB 4PK611	43
------------	-------------	-----------------	--	--	-----------	----

### H100 (P)

2.5 D; 2.5 TD	07.93-03.00	D4BA; D4BF; D4BX; (55-59kW)			FB 13X750	43
---------------	-------------	-----------------------------	--	--	-----------	----

2.5 D; 2.5 TDiC	12.94-10.03	D4BA; D4BF; (57-59kW)		A/C,  05.99→	FB 13X1400	43
-----------------	-------------	-----------------------	--	--------------	------------	----

					FB 13X750	43
--	--	--	--	--	-----------	----

### i20 (PB, PBT)

1.1 CRDi; 1.4 CRDi; 1.6 CRDi	08.08-12.15	D3FA; D4FB; D4FC; (55-94kW)		START/STOP, A/C	529 0195 10	39
------------------------------	-------------	-----------------------------	--	-----------------	-------------	----

### i30 (GD, GD)

1.4 CRDi; 1.6 CRDi	12.11-12.16	D4FB; D4FB-5P; D4FC; (66-94kW)		START/STOP, A/C	529 0195 10	39
--------------------	-------------	--------------------------------	--	-----------------	-------------	----

### i30 Coupé

1.4 CRDi; 1.6 CRDi	05.13-	D4FB; D4FC; (66-94kW)		START/STOP, A/C	529 0195 10	39
--------------------	--------	-----------------------	--	-----------------	-------------	----

### ix20 (JC)

1.4 CRDi; 1.6 CRDi	11.10-	D4FB; D4FC; D4FC-M; (57-94kW)		START/STOP, A/C	529 0195 10	39
--------------------	--------	-------------------------------	--	-----------------	-------------	----

### ix35 (LM, EL, ELH)

1.7 CRDi	11.10-	D4FD; (85kW)		START/STOP, A/C	529 0195 10	39
----------	--------	--------------	--	-----------------	-------------	----

### LANTRA I (J-1)

1.6 i.e. 16V	10.90-11.95	G4CR; (78-84kW)			FB 13X675	43
--------------	-------------	-----------------	--	--	-----------	----

### LANTRA II (J-2, J-2)

1.5 12V	12.96-10.00	G4EK; (65kW)			FB 4PK611	43
---------	-------------	--------------	--	--	-----------	----

### PONY A trois volumes (X-1)

1.3; 1.5	10.85-09.89	G13B; G15B; G4DJ; (50-53kW)			FB 13X675	43
----------	-------------	-----------------------------	--	--	-----------	----

### SANTAMO

2.0 16V	05.99-12.02	G4JP; (102kW)			FB 13X675	43
---------	-------------	---------------	--	--	-----------	----

### SONATA II (Y-2)

2.0 i 16V	01.91-10.93	G4CP-D; (96kW)			FB 13X675	43
-----------	-------------	----------------	--	--	-----------	----

### SONATA III (Y-3)

2.0 i 16V	05.93-06.98	G4CP-D; G4CP-DM; (92-102kW)			FB 13X675	43
-----------	-------------	-----------------------------	--	--	-----------	----

## IVECO

### DAILY I

40-10; 40-10 V; 45-10 V; 49-10; 49-10 V	01.85-12.89	8140.21.200; 8140.27 S; (68kW)		WP, A/C	FB 13X750	43
---	-------------	--------------------------------	--	---------	-----------	----

### DAILY II

35-10; 35-12; 40-10 V; 45-10; 45-10 V; 49-10; 49-10 K; 49-10 V; 49-12; 49-12 K; 49-12 V; 59-12; 59-12 K; 59-12 V; A 40-10; A 45-10; A 45-12	01.89-08.98	8140.27.2700; 8140.27.2720; 8140.47.2700; 8140.47.2711; 8140.47.2721; 8140.47R; 8140.47R.2790; 8140.47S; 8140.97.2781; (68-85kW)		WP, A/C	FB 13X750	43
---	-------------	--	--	---------	-----------	----

--	--	--	--	--	--	--

## JAGUAR

### XJ

12 5.3; Sovereign V12	09.73-02.93	7P; V 12 (75-79); V 12 (90-93, 197kW); (186-211kW)		WP,	FB 13X1075	42
-----------------------	-------------	--	--	-----	------------	----

6 2.8	09.68-10.75	(110kW)		WP, FAN	FB 13X750	43
-------	-------------	---------	--	---------	-----------	----

--	--	--	--	--	--	--

### XJ / XJS / XJSC (X27, XJ40, XJ81)

5.3; 5.3 H.E.	09.73-08.93	8C (88-92); 8S (86-88); 8S (92-93); V 12 (82-90); V 12 (90-93, 197kW); V 12 (90-93, 211kW); (194-217kW)		WP,	FB 13X1075	42
---------------	-------------	---	--	-----	------------	----

6 2.9	10.86-08.90	AJ 6 (2.9, KAT); AJ 6 (2.9); (108-117kW)		WP, FAN	FB 13X750	43
-------	-------------	--	--	---------	-----------	----

--	--	--	--	--	--	--

--	--	--	--	--	--	--

## JEEP

### CHEROKEE (XJ)

2.5 TD 4x4; 2.5 Tdi 4x4	01.88-09.01	ENC; (85kW)			FB 8PK2188	45
-------------------------	-------------	-------------	--	--	------------	----

### GRAND CHEROKEE I (ZJ)

2.5 TD 4x4; 2.5 TD Laredo	10.95-04.99	M51; M52; (85kW)			FB 8PK2188	45
---------------------------	-------------	------------------	--	--	------------	----

### WRANGLER I (YJ, SJ\_)

4.0	12.91-08.96	ERH; (131kW)			FB 6PK1755	44
-----	-------------	--------------	--	--	------------	----

--	--	--	--	--	--	--

--	--	--	--	--	--	--

--	--	--	--	--	--	--

--	--	--	--	--	--	--

--	--	--	--	--	--	--

--	--	--	--	--	--	--

--	--	--	--	--	--	--

--	--	--	--	--	--	--

--	--	--	--	--	--	--

--	--	--	--	--	--	--

--	--	--	--	--	--	--

--	--	--	--	--	--	--

--	--	--	--	--	--	--

**KIA**
**JOICE**

2.0	02.00-	G4CP; (88-102kW)		A/C	FB 13X675	43
-----	--------	------------------	--	-----	-----------	----

**PRO CEE'D (JD)**

1.4 CRDi 90; 1.6 CRDi 110; 1.6 CRDi 128	03.13-	D4FB; D4FC; (66-94kW)		START/STOP, A/C	529 0195 10	39
---	--------	-----------------------	--	-----------------	-------------	----

**RETONA (CE)**

2.0 16V	05.00-	FE (16V); (94kW)			FB 13X775	43
---------	--------	------------------	--	--	-----------	----

**RIO II (JB, JB)**

1.6 16V; 1.6 CVVT	03.05-	G4ED; (82kW)			FB 13X675	43
-------------------	--------	--------------	--	--	-----------	----

**RIO III (UB)**

1.1 CRDi; 1.4 CRDi	09.11-	D3FA; D4FC; (55-66kW)		START/STOP, A/C	529 0195 10	39
--------------------	--------	-----------------------	--	-----------------	-------------	----

**SOUL (AM) / SOUL II (PS)**

1.6 CRDi 115; 1.6 CRDi 128	02.09-	D4FB; (85-94kW)		START/STOP, A/C	529 0195 10	39
----------------------------	--------	-----------------	--	-----------------	-------------	----

**SPORTAGE (K00)**

2.0; 2.0 4WD; 2.0 i 16V; 2.0 i 16V 4WD; 2.0 i 4WD	04.94-08.03	FE (16V); FE (8V); (70-94kW)			FB 13X775	43
---	-------------	------------------------------	--	--	-----------	----

**SPORTAGE (SL)**

1.7 CRDi	12.10-	D4FD-L; (85kW)		START/STOP, A/C	529 0195 10	39
----------	--------	----------------	--	-----------------	-------------	----

**VENGA (YN)**

1.4 CRDi 75; 1.4 CRDi 90; 1.6 CRDi 115; 1.6 CRDi 128	02.10-	D4FB; D4FC; (55-94kW)		START/STOP, A/C	529 0195 10	39
--	--------	-----------------------	--	-----------------	-------------	----

**LADA**
**NIVA Véhicule tout terrain fermé (2121)**

1900 Diesel	01.93-12.06	XUD9A; XUD9SD; (47-55kW)			FB 4PK1230	43
-------------	-------------	--------------------------	--	--	------------	----

**LANCIA**
**DEDRA (835\_) / DEDRA SW (835\_)**

1.6; 1.6 i.e.; 1.6 LE Cat	04.93-07.99	159 B9.000; 835 C1.000; (55-66kW)			FB 10X690	41
---------------------------	-------------	-----------------------------------	--	--	-----------	----

1.8 i.e.; 2.0 16V; 2.0 HF Integrale; 2.0 i.e.; 2.0 i.e. Turbo; 2.0 i.e. Turbo Integrale; 2.0 Integrale; 2.0 Turbo	09.89-07.99	835 A2.000; 835 A2.046; 835 A5.000; 835 A5.046; 835 A7.000; 835 A7.046; 835 A8.000; 835 A8.046; 835 C5.000; 836 A3.000; 836 A5.000; (66-130kW)		A/C	FB 13X750	43
---	-------------	--	--	-----	-----------	----

**DELTA II (836\_)**

1.6 i.e.	06.93-08.99	835 C1.000; (55kW)			FB 10X690	41
----------	-------------	--------------------	--	--	-----------	----

1.8 i.e.; 2.0 16V; 2.0 16V Turbo	06.93-08.99	175 A4.000; 835 C2.000; 835 C4.000; 836 A2.000; 836 A3.000; 836 A6.000; 836 C4.000; (66-142kW)		A/C	FB 13X750	43
----------------------------------	-------------	--	--	-----	-----------	----

**DELTA III (844\_)**

1.6 D Multijet; 1.9 D Multijet; 2.0 D Multijet	08.08-08.14	198 A2.000; 198 A5.000; 198 A8.000; 844 A1.000; 844 A2.000; 955 A4.000; (85-140kW)		→12.09	534 0610 10	40
--	-------------	--	--	--------	-------------	----

**KAPPA (838\_, 838\_, 838\_)**

2.0 16V Turbo	02.95-10.01	838 A4.000; (151kW)		A/C	FB 13X750	43
---------------	-------------	---------------------	--	-----	-----------	----

**MUSA (350\_)**

1.6 D Multijet	07.08-09.12	350 A2.000; (88kW)			534 0610 10	40
----------------	-------------	--------------------	--	--	-------------	----

1.6 D Multijet	07.08-09.12	350 A2.000; 350 A3.000; (85kW)		350A3.000	534 0610 10	40
----------------	-------------	--------------------------------	--	-----------	-------------	----

**PHEDRA (179\_)**

2.2 JTD	04.06-11.10	4HP; 4HR; (120kW)			544 0112 10	41
---------	-------------	-------------------	--	--	-------------	----

**THEMA (834\_, 834\_)**

2000 16V; 2000 16V Turbo; 2000 i.e. 16V; 2000 i.e. 16V Turbo; 2000 i.e.; 2000 Turbo; 2000 Turbo 16V	05.88-07.94	834 B1.000; 834 B2.000; 834 B2.246; 834 C.146; 834 C1.000; 834 C1.246; 834 F1.000; 834 F2.000; (86-148kW)		A/C	FB 13X750	43
---	-------------	---	--	-----	-----------	----

2000 i.e. Turbo	07.86-05.90	834 C.146; (110kW)		01.89→, A/C	FB 13X750	43
-----------------	-------------	--------------------	--	-------------	-----------	----

2500 Turbo D; 2500 Turbo DS	11.84-05.92	8144.91; 8144.97; (74-85kW)		HYDP	FB 10X715	42
-----------------------------	-------------	-----------------------------	--	------	-----------	----

2850 V6 i.e.	06.88-05.92	834 E.146; (108kW)		A/C	FB 10X690	41
--------------	-------------	--------------------	--	-----	-----------	----

2850 V6 i.e.	11.84-09.88	834 E.000; (110kW)		→12.86	FB 13X1225	42
--------------	-------------	--------------------	--	--------	------------	----

2850 V6 i.e.	11.84-09.88	834 E.000; (110kW)		A/C	FB 13X1400	43
--------------	-------------	--------------------	--	-----	------------	----

**Y (840\_)**

1.2	03.96-09.03	188 A4.000; 840 A3.000; (44kW)		A/C, → 188 A4.000	529 0223 10	39
-----	-------------	--------------------------------	--	-------------------	-------------	----

				A/C	FB 5PK1570	44
--	--	--	--	-----	------------	----

				08.00→, →12.01, A/C	FB 5PK1585	44
--	--	--	--	---------------------	------------	----

1.2 16V	10.00-09.03	188 A5.000; (59kW)		A/C	529 0223 10	39
---------	-------------	--------------------	--	-----	-------------	----

				A/C, → 616580→	FB 5PK1570	44
--	--	--	--	----------------	------------	----

				→616579, A/C	FB 5PK1585	44
--	--	--	--	--------------	------------	----

# LAND ROVER



## LAND ROVER

### 88/109 (LR)

2.3 4x4	09.63-12.86	10 H; 11H; (51kW)			→12.83	FB 13X750	43
2.3 D 4x4	09.63-12.86	10 J; 23 J; (46kW)			Pompe à vide, 01.83→,	FB 10X715	42
					→12.83	FB 13X750	43

### 88/109 Hardtop (LR)

2.3 4x4; 2.3 D 4x4	09.63-12.86	10 H; 10 J; 11H; 23 J; (46-51kW)				FB 13X750	43
--------------------	-------------	----------------------------------	--	--	--	-----------	----

### DEFENDER (L316, L316)

2.5 4x4; 2.5 D 4x4	09.90-09.01	12 J; 17 H; (51-61kW)			A/C	FB 13X750	43
2.5 TDI 4x4	09.90-12.01	11 L; 16 L; 23 L; (83kW)			16 L, →16L25164	FB 7PK1593	45

### DISCOVERY I (LJ)

2.5 TDI 4x4	10.89-10.98	12 L; 17 L; 19 L; 21 L; (83kW)			A/C	FB 13X1350	42
-------------	-------------	--------------------------------	--	--	-----	------------	----

### FREELANDER 2 (L359)

2.0 Si4 4x4	10.11-10.14	204PT; (177kW)				532 0824 10	40
2.2 eD4; 2.2 TD4 4x4	10.06-10.14	224DT; DW12BTED4; (110-118kW)				544 0112 10	41

### RANGE ROVER I

2.5 TD 4x4; 2.5 TDi 4x4	10.89-04.94	14 L; 21 L; (83-89kW)			A/C	FB 13X1350	42
-------------------------	-------------	-----------------------	--	--	-----	------------	----

### RANGE ROVER EVOQUE (L538)

2.0 4x4	06.11-	204PT; (177kW)				532 0824 10	40
---------	--------	----------------	--	--	--	-------------	----

## MAZDA

### 2 (DL, DJ)

1.5 D	11.14-	S5Y5; (77kW)				529 0275 10	39
-------	--------	--------------	--	--	--	-------------	----

### 3 (BM, BN, BM, BN)

1.5 D; 2.2 D	09.13-	S5Y5; SHY1; (77-110kW)				529 0275 10	39
2.0	09.13-	PEY7; (88-121kW)				529 0150 10	39
					WP	FB 3PK798	43
2.0	11.14-	PEX2; (121kW)				529 0150 10	39
					WP, →05.16	FB 3PK798	43

### 6 (GJ, GL, GJ, GL)

2.0	01.13-	PEY7; (107-121kW)				529 0150 10	39
					WP	FB 3PK798	43

### 121 III (JASM, JBSM)

1.8 D	03.96-04.03	RTJ; RTK; (44kW)				FB 5PK675	44
-------	-------------	------------------	--	--	--	-----------	----

### 323 III (BF, BF)

1.7 D	04.86-05.89	PN27; (40kW)			A/C	FB 13X1075	42
-------	-------------	--------------	--	--	-----	------------	----

### 323 C IV (BG)

1.7 D	08.89-07.94	PN54; (41kW)			A/C	FB 13X1075	42
-------	-------------	--------------	--	--	-----	------------	----

### 323 III Break (BW)

1.7 D	11.86-10.89	PN26; PN54; (40-42kW)			A/C	FB 13X1075	42
1.7 D	10.89-03.93	PN26; PN54; (41kW)			→12.89, A/C	FB 13X1075	42

### 626 IV (GE, GE)

2.0 D GLX Complex	10.92-04.97	RF55; (55kW)			TURBOC	FB 5PK675	44
-------------------	-------------	--------------	--	--	--------	-----------	----

### 626 III Break (GV)

2.0 D; 2.0 D Complex	05.93-09.97	RF-CX; RFG5; (55-60kW)			TURBOC	FB 5PK675	44
----------------------	-------------	------------------------	--	--	--------	-----------	----

### CX-3 (DK)

1.5 D; 1.5 D AWD	05.15-	S5-DPTR; S5-DPTS; (77kW)				529 0275 10	39
2.0; 2.0 AWD	05.15-	(88-110kW)			WP	FB 3PK798	43

### CX-5 (KE, GH)

2.0; 2.0 AWD	11.11-02.17	PEY6; PEY7; (118-121kW)				529 0150 10	39
					WP	FB 3PK798	43

### E-SERIE (SR1, SR2)

E2000	11.84-05.03	FE (8V); FE18; FE58; FE60; FE61; FEV4; (60-70kW)				FB 13X775	43
-------	-------------	--	--	--	--	-----------	----

### RX-7 I (SA) / RX-7 II (FC)

1.1; 1.3	03.84-04.89	12AN2; RE13B; (83-110kW)			A/C, →12.85	FB 13X1075	42
----------	-------------	--------------------------	--	--	-------------	------------	----

## MERCEDES-BENZ

### /8 (W114, W115) / /8 Coupé (W114)

200; 200 D; 220 D; 230.4; 230.6	01.68-01.77	M 115.923; M 115.926; M 115.951; M 180.954; OM 615.912; OM 615.913; (40-88kW)				FB 13X750	43
220	01.68-07.73	M 115.920; M 115.924; (66-77kW)			A/C	FB 13X1375	42
						FB 13X750	43
250 2.8; 250 C 2.8	06.72-11.76	M 130.923; (96kW)			A/C	FB 13X1350	42

**MERCEDES-BENZ**

<b>190 (W201)</b>						
2.0; E 2.0	10.82-06.93	M 102.921; M 102.961; M 102.962; (66-90kW)		→08.84	FB 13X750	43
<b>200 - 300 (C123, S123, W123)</b>						
200	02.76-08.80	M 115.938; M 115.939; (62-69kW)		A/C	FB 13X1375	42
					FB 13X750	43
200; 200 T; 230; 230 C; 230 CE; 230 E; 230 T; 230 TE	02.76-12.85	M 102.920; M 102.939; M 102.980; M 115.954; (74-100kW)			FB 13X750	43
200 D; 220 D	01.76-11.85	OM 615.940; OM 615.941; (40-49kW)		A/C	FB 13X1350	42
240 D; 240 T D	02.76-12.85	OM 616.912; (48-53kW)		A/C	FB 13X1375	42
300 D; 300 T D	02.76-11.85	OM 617.912; (59-65kW)		A/C	FB 13X1350	42
				A/C	FB 13X1375	42
<b>CLASSE C (W205)</b>						
AMG C 43 4-matic; C 450 AMG 4-matic	04.15-04.16	M 276.823; (270kW)			535 0328 10	41
<b>CLASSE C Décapotable (A205)</b>						
AMG C 43 4-matic	10.16-	M 276.823; (270kW)			535 0328 10	41
<b>CLASSE C Coupé (C205)</b>						
AMG C 43 4-matic	04.16-	M 276.823; (270kW)			535 0328 10	41
<b>CLASSE C T-Model (S205)</b>						
AMG C 43 4-matic; C 450 AMG 4-matic	04.15-04.16	M 276.823; (270kW)			535 0328 10	41
<b>CLASSE C Coupe Sport (CL203)</b>						
C 160 Kompressor; C 180 Kompressor; C 200 CGI Kompressor; C 200 Kompressor; C 230 Kompressor	05.02-05.08	M 271.921; M 271.940; M 271.942; M 271.946; M 271.948; (90-141kW)		WP,  A/C	FB 7PK2418	45
C 200 CDI	03.03-05.08	OM 646.962; (90kW)		Ø 152 mm, ≡ 30085732→,  07.03→	544 0111 10	41
C 220 CDI	03.01-01.04	OM 611.962; (100-105kW)		Ø 152 mm, Boîte automatique à 5 vitesses	544 0111 10	41
C 220 CDI	02.04-05.08	OM 646.963; (110kW)		Ø 152 mm, ≡ 30085732→	544 0111 10	41
C 230; C 350	01.05-05.08	M 272.920; M 272.960; (150-200kW)		Ø 152 mm, ≡ 30085732→, ≡ 30621934→	532 0866 10	40
<b>CLASSE C T-Model (S203)</b>						
C 180 Kompressor; C 200 CGI Kompressor; C 200 Kompressor; C 230 Kompressor	05.02-08.07	M 271.940; M 271.942; M 271.946; M 271.948; (105-141kW)		WP,  A/C	FB 7PK2418	45
C 200 CDI	03.01-08.07	OM 611.962; OM 646.962; (75kW)		Ø 152 mm, Boîte automatique à 5 vitesses	544 0111 10	41
				Ø 152 mm, ≡ 30085732→,  07.03→	544 0111 10	41
C 200 CDI; C 220 CDI	03.01-08.07	OM 611.962; (85-105kW)		Ø 152 mm, Boîte automatique à 5 vitesses	544 0111 10	41
C 200 CDI	04.03-08.07	OM 646.962; (90kW)		Ø 152 mm, ≡ 30085732→,  07.03→	544 0111 10	41
C 220 CDI	02.04-08.07	OM 646.963; (100-110kW)		Ø 152 mm, ≡ 30085732→	544 0111 10	41
C 230; C 280 4-matic; C 350; C 350 4-matic	01.05-08.07	M 272.920; M 272.941; M 272.960; M 272.970; (150-200kW)		Ø 152 mm, ≡ 30085732→, ≡ 30621934→	532 0866 10	40
C 270 CDI	03.01-08.07	OM 612.962; (125kW)		Ø 152 mm,  MANU	544 0111 10	41
C 280	01.05-08.07	M 272.940; (170kW)			532 0866 10	40
<b>CLASSE C (W203)</b>						
C 180 Kompressor; C 200 CGI Kompressor; C 200 Kompressor; C 230 Kompressor	05.02-02.07	M 271.940; M 271.942; M 271.946; M 271.948; (105-141kW)		WP,  A/C	FB 7PK2418	45
C 200 CDI; C 220 CDI	05.00-02.07	OM 611.962; (85-100kW)		Ø 152 mm, Boîte automatique à 5 vitesses	544 0111 10	41
C 200 CDI; C 220 CDI	02.01-02.07	OM 611.962; OM 646.962; OM 646.963; (75-110kW)		Ø 152 mm, ≡ 30085732→,  07.03→	544 0111 10	41
C 220 CDI	05.00-02.07	OM 611.962; OM 646.963; (105kW)		Ø 152 mm, Boîte automatique à 5 vitesses	544 0111 10	41
				Ø 152 mm, ≡ 30085732→,  07.03→	544 0111 10	41
C 270 CDI	12.00-02.07	OM 612.962; (125kW)		Ø 152 mm,  MANU	544 0111 10	41
C 280; C 280 4-matic; C 350 4-matic	01.05-02.07	M 272.940; M 272.941; M 272.960; M 272.970; (170-200kW)			532 0866 10	40
<b>CLASSE C T-Model (S204)</b>						
C 180 Kompressor; C 200 CGI; C 200 Kompressor	08.07-08.14	M 271.820; M 271.860; M 271.910; M 271.950; M 271.952; (115-135kW)		WP,  A/C	FB 7PK2418	45



# MERCEDES-BENZ



## MERCEDES-BENZ

### CLASSE C T-Model (S204)

C 230; C 280; C 300; C 350	08.07-08.14	M 272.921; M 272.947; M 272.961; (150-200kW)				532 0866 10	40
----------------------------	-------------	--	--	--	--	-------------	----

### CLASSE C (W204)

C 180 Kompressor; C 200 CGI; C 200 Kompressor	01.07-01.14	M 271.820; M 271.860; M 271.910; M 271.950; M 271.952; (115-135kW)			WP, , A/C	FB 7PK2418	45
C 230; C 280; C 350	01.07-01.14	M 272.921; M 272.947; M 272.961; (150-200kW)			03.07→,  30621934→	532 0866 10	40
C 230 4-matic; C 280 4-matic; C 300; C 300 4-matic; C 350 4-matic; C 350 CGI	07.07-01.14	M 272.911; M 272.947; M 272.948; M 272.971; M 272.982; (150-215kW)				532 0866 10	40

### CLASSE E (W213)

AMG E 43 4-matic	07.16-	M 276.823; (295kW)				535 0328 10	41
------------------	--------	--------------------	--	--	--	-------------	----

### CLASSE G (W460)

230 G; 240 GD; 300 GD	03.79-07.93	M 115.973; OM 616.936; OM 617.931; (53-75kW)			A/C	FB 13X1350	42
230 GE	04.82-08.92	M 102.979; M 102.981; M 102.987; M 102.989; (90-92kW)				FB 13X750	43

### CLASSE R (W251, V251) / CLASSE S (W221)

R 280; R 280 4-matic; R 300; R 500 4-matic; S 350 4-matic; S 400 Hybrid; S 450; S 450 4-matic; S 500; S 500 4-matic	10.05-12.13	M 272.945; M 272.974; M 272.975; M 273.922; M 273.924; M 273.961; M 273.963; M 273.968; (170-285kW)				532 0866 10	40
R 350; R 350 4-matic; S 280; S 300; S 350	10.05-12.13	M 272.946; M 272.965; M 272.967; (170-200kW)			03.07→,  30621934→	532 0866 10	40

### CLASSE S (W222, V222, X222)

S 400 Hybrid / h	05.13-	M 276.960; (225kW)				535 0328 10	41
------------------	--------	--------------------	--	--	--	-------------	----

### CLASSE S A trois volumes (W108, W109)

250 S; 250 SE; 280 SE,SEL	01.66-08.72	M 108.920; M 129.980; M 130.980; (96-118kW)				FB 13X750	43
280 S	10.67-07.72	M 130.920; (103kW)			01.68→	FB 13X750	43

### CLASSE S Coupé (C216)

CL 500; CL 500 4-matic	06.06-12.13	M 273.961; M 273.968; (285kW)				532 0866 10	40
------------------------	-------------	-------------------------------	--	--	--	-------------	----

### CLASSE CLC (CL203)

CLC 160; CLC 180 Kompressor; CLC 200 Kompressor	05.08-06.11	M 271.911; M 271.946; M 271.957; (95-135kW)			WP, , A/C	FB 7PK2418	45
CLC 200 CDI; CLC 220 CDI	05.08-06.11	OM 646.962; OM 646.963; (90-110kW)			Ø 152 mm, 30085732→	544 0111 10	41
CLC 230; CLC 350	05.08-06.11	M 272.920; M 272.960; (150-200kW)				532 0866 10	40

### CLK Décapotable (A209)

CLK 200 Kompressor	02.03-03.10	M 271.940; M 271.955; (120-135kW)			WP, , A/C	FB 7PK2418	45
CLK 280; CLK 350	01.05-03.10	M 272.940; M 272.960; (170-200kW)			03.07→,  30621934→	532 0866 10	40
CLK 500	06.06-03.10	M 273.967; (285kW)				532 0866 10	40

### CLK (C209)

200 Kompressor	09.02-05.09	M 271.940; M 271.955; (120-135kW)			WP, , A/C	FB 7PK2418	45
220 CDI	01.05-05.09	OM 646.966; (100-110kW)			Ø 152 mm, 30085732→	544 0111 10	41
270 CDI	10.02-05.09	OM 612.962; OM 612.967; (125kW)			Ø 152 mm,  MANU	544 0111 10	41
280; 350	01.05-05.09	M 272.940; M 272.960; (170-200kW)			03.07→,  30621934→	532 0866 10	40
500	06.06-05.09	M 273.965; (285kW)				532 0866 10	40

### CLS (C219)

CLS 280; CLS 300; CLS 350 CGI; CLS 500	04.06-12.10	M 272.943; M 272.985; M 273.960; (170-285kW)				532 0866 10	40
CLS 350	10.04-12.10	M 272.964; M 272.985; (200-215kW)			03.07→,  30621934→	532 0866 10	40

### COUPE (W111)

220 SEB; 250 SE; 280 SE	01.61-12.71	M 127.984; M 129.980; M 129.981; M 130.980; M 130.984; (88-118kW)				FB 13X750	43
-------------------------	-------------	---	--	--	--	-----------	----

### CLASSE E T-Model (S213)

AMG E 43 4-matic	10.16-	M 276.823; (295kW)				535 0328 10	41
------------------	--------	--------------------	--	--	--	-------------	----

### CLASSE E Décapotable (A207)

E 350 CGI; E 500	01.10-	M 272.982; M 272.984; M 273.966; (215-285kW)				532 0866 10	40
------------------	--------	--	--	--	--	-------------	----

### CLASSE E Coupé (C207)

E 350 CGI; E 500	01.09-	M 272.982; M 272.984; M 273.966; (215-285kW)				532 0866 10	40
------------------	--------	--	--	--	--	-------------	----

### CLASSE E Break (S210)

E 220 T CDI	06.98-03.03	OM 611.961; (92-105kW)			Ø 152 mm,  MY 2000→	544 0111 10	41
-------------	-------------	------------------------	--	--	---------------------	-------------	----

### CLASSE E (W210)

E 200 CDI; E 220 CDI	06.98-03.02	OM 611.961; (75-105kW)			Ø 152 mm,  MY 2000→	544 0111 10	41
----------------------	-------------	------------------------	--	--	---------------------	-------------	----



**MERCEDES-BENZ**

<b>CLASSE E T-Model (S211)</b>							
350 CGI; E 280 T; E 280 T 4-matic; E 350 T; E 350 T 4-matic	03.05-07.09	M 272.943; M 272.964; M 272.972; M 272.985; (170-215kW)		03.07→,  30621934→	<b>532 0866 10</b>	40	
E 200 Kompressor; E 200 T Kompressor	03.03-07.09	M 271.941; M 271.956; (120-135kW)		WP,  A/C	<b>FB 7PK2418</b>	45	
E 220 CDI; E 220 T CDI	03.03-07.09	OM 646.961; (100-110kW)		Ø 152 mm, 30085732→,  07.03→	<b>544 0111 10</b>	41	
E 230 T; E 500 T; E 500 T 4-matic	04.06-07.09	M 272.922; M 273.960; M 273.962; (150-285kW)			<b>532 0866 10</b>	40	
E 270 T CDI	03.03-07.09	OM 647.961; (130kW)		Ø 152 mm, 30070144→,  08.03→	<b>544 0111 10</b>	41	
<b>CLASSE E (W211)</b>							
E 200 CDI; E 220 CDI	03.02-12.08	OM 646.951; OM 646.961; (75-110kW)		Ø 152 mm, 30085732→,  07.03→	<b>544 0111 10</b>	41	
E 200 Kompressor; E 200 NGT	03.04-12.08	M 271.941; M 271.956; (120-135kW)		WP,  A/C	<b>FB 7PK2418</b>	45	
E 200 Kompressor	11.02-12.08	M 271.941; (120kW)		Ø 152 mm, 30085732→,  07.03→	<b>544 0111 10</b>	41	
E 230; E 350 CGI; E 500; E 500 4-matic	04.06-12.08	M 272.922; M 272.985; M 273.960; M 273.962; (150-285kW)			<b>532 0866 10</b>	40	
E 270 CDI	03.02-12.08	OM 647.961; (130kW)		Ø 152 mm, 30070144→,  08.03→	<b>544 0111 10</b>	41	
E 280; E 280 4-matic; E 350; E 350 4-matic	03.05-12.08	M 272.943; M 272.964; M 272.972; (170-200kW)		03.07→,  30621934→	<b>532 0866 10</b>	40	
<b>CLASSE E T-Model (S212)</b>							
E 300; E 350; E 350 4-matic; E 350 CGI; E 500	08.09-	M 272.952; M 272.977; M 272.980; M 272.983; M 273.971; (170-285kW)			<b>532 0866 10</b>	40	
<b>CLASSE E (W212)</b>							
E 300; E 350; E 350 4-matic; E 350 CGI; E 500; E 500 4-matic	01.09-08.11	M 272.952; M 272.977; M 272.980; M 272.982; M 272.983; M 273.970; M 273.971; (170-285kW)			<b>532 0866 10</b>	40	
<b>GLC (X253) / GLC Coupé (C253)</b>							
AMG 43 4-matic	04.16-	M 276.823; (270kW)			<b>535 0328 10</b>	41	
<b>GLE (W166) / GLE Coupé (C292)</b>							
450 AMG 4-matic; AMG 43 4-matic	03.15-04.16	M 276.821; (270kW)			<b>535 0328 10</b>	41	
<b>CLASSE GLK (X204)</b>							
280 4-matic; 300 4-matic; 350; 350 4-matic	06.08-06.15	M 272.948; M 272.971; M 272.991; (170-200kW)			<b>532 0866 10</b>	40	
<b>CLASSE GL (X164)</b>							
GL 450 4-matic; GL 500 4-matic	09.06-	M 273.923; M 273.963; (250-285kW)			<b>532 0866 10</b>	40	
<b>G-Model (W463, W463)</b>							
G 270 CDI	10.01-	OM 612.965; (115kW)		Ø 152 mm,	<b>544 0111 10</b>	41	
G 500	05.08-	M 273.963; M 273.969; (285kW)			<b>532 0866 10</b>	40	
<b>HECKFLOSSE (W111, W112)</b>							
220 B; 220 SB; 220 SEB	08.59-08.65	M 127.982; M 180.940; M 180.941; (70-88kW)			<b>FB 13X750</b>	43	
<b>CLASSE M (W163)</b>							
ML 270 CDI	12.99-06.05	OM 612.963; (120kW)		Ø 152 mm,  MANU	<b>544 0111 10</b>	41	
<b>CLASSE M (W164)</b>							
ML 350 4-matic	07.05-12.11	M 272.967; (200kW)		03.07→,  30621934→	<b>532 0866 10</b>	40	
ML 500 4-matic	12.07-12.11	M 273.963; (285kW)			<b>532 0866 10</b>	40	
<b>PAGODE (W113)</b>							
230 SL	01.63-01.67	M 127.981; (110kW)		→12.65	<b>FB 13X750</b>	43	
250 SL	01.66-01.68	M 129.982; (110kW)		A/C,  01.68→	<b>FB 13X1075</b>	42	
280 SL	01.68-03.71	M 130.983; (125kW)		A/C	<b>FB 13X750</b>	43	
					<b>FB 13X1075</b>	42	
					<b>FB 13X750</b>	43	
<b>PONTON (W128, W180)</b>							
220; 220 S; 220 SE	01.54-12.59	M 127.980; M 180.921; M 180.924; (63-88kW)			<b>FB 13X750</b>	43	
<b>SL (R107, C107)</b>							
280 SL; 280 SLC	08.74-07.85	M 110.982; M 110.986; M 110.990; (130-136kW)			<b>FB 13X775</b>	43	
<b>SL (R230)</b>							
280; 300; 350; 500	03.06-01.12	M 272.949; M 272.968; M 273.965; (170-285kW)			<b>532 0866 10</b>	40	
350	03.06-01.12	M 272.966; (200kW)		03.07→,  30621934→	<b>532 0866 10</b>	40	
<b>SLK (R171)</b>							
200 Kompressor	03.04-02.11	M 271.944; M 271.954; (120-135kW)		WP,  A/C	<b>FB 7PK2418</b>	45	



**MINI**

**MERCEDES-BENZ**

<b>SLK (R171)</b>							
280; 350	06.04-02.11	M 272.942; M 272.963; (170-200kW)		03.07→,  30621934→	<b>532 0866 10</b>	40	
300; 350	01.08-02.11	M 272.942; M 272.969; (170-224kW)			<b>532 0866 10</b>	40	
<b>Sprinter (905, 905)</b>							
616 CDI	04.01-05.06	OM 612.981; (115kW)		Ø 216 mm, →50 076683	<b>544 0111 10</b>	41	
<b>Sprinter (901, 902, 901, 902, 901, 902)</b>							
216 CDI	04.00-05.06	OM 612.981; (115kW)		Ø 216 mm, →50 076683	<b>544 0111 10</b>	41	
<b>Sprinter (903, 903, 903)</b>							
316 CDI; 316 CDI 4x4	04.00-05.06	OM 612.981; (115kW)		Ø 216 mm, →50 076683	<b>544 0111 10</b>	41	
<b>Sprinter (904, 904, 904)</b>							
416 CDI; 416 CDI 4x4	04.00-05.06	OM 612.981; (115kW)		Ø 216 mm, →50 076683	<b>544 0111 10</b>	41	
<b>Sprinter (906, 906, 906, 906, 906, 906, 906, 906, 906, 906)</b>							
224; 324; 424; 524	06.06-12.13	M 272.979; (190kW)		03.07→,  30621934→	<b>532 0866 10</b>	40	
<b>VIANO (W639)</b>							
3.5	09.07-	M 272.978; (190kW)			<b>532 0866 10</b>	40	
<b>VITO (W639, W639)</b>							
126	09.07-	M 272.978; (190kW)			<b>532 0866 10</b>	40	

**MINI**

<b>MINI (F55, F56) / MINI CLUBMAN (F54)</b>							
Cooper; Cooper D; Cooper S; Cooper SD; John Cooper Works; One; One D; One First	04.13-	B36 A15 A; B37 C15 A; B38 A12 A; B38 A15 A; B46 A20 A; B47 C20 A; B48 A20 A; B48 A20 B; (55-170kW)			<b>532 0804 10</b>	40	

**MITSUBISHI**

<b>ASX (GA_W_)</b>							
1.8 DI-D; 1.8 DI-D 4WD; 2.2 Di-D 4WD	06.10-	4N13; 4N14; (85-110kW)		WP	<b>FB 3EPK863</b>	43	
<b>GALANT IV (E3_A, E3_A)</b>							
2.0; 2.0 4WD; 2.0 GTi 16V; 2.0 GTi 16V 4WD; 2.0 GTi 16V 4x4	11.87-12.92	4G63 (DOHC 16V); 4G63 (SOHC 8V); (80-107kW)			<b>FB 13X675</b>	43	
<b>L 300 / DELICA II Autobus/Autocar (L03_P/G, L0_2P)</b>							
2.3 D	04.83-10.86	4D55; (50kW)			<b>FB 13X750</b>	43	
<b>L 300 / DELICA II Camionnette (L03_P)</b>							
2.3 D	09.83-10.86	4D55; (50kW)			<b>FB 13X750</b>	43	
<b>L 300 (P0_W, P1_W, P2_W, P0_V, P1_V, P_2V)</b>							
2.5 D; 2.5 TD 4WD	11.86-02.06	4D56 (8V); 4D56 T; (51-64kW)			<b>FB 13X750</b>	43	
<b>LANCER III (C1_A, C6_A)</b>							
1.8 Diesel	01.84-04.88	4D65; (43-44kW)			<b>FB 13X675</b>	43	
<b>LANCER VIII (CX_A, CY_A, CZ_A)</b>							
1.8 DI-D	05.10-	4N13; (85-110kW)		WP	<b>FB 3EPK863</b>	43	
<b>OUTLANDER II (CW_W)</b>							
2.2 DI-D; 2.2 DI-D 4WD	11.06-11.12	4N14; (103-130kW)		WP	<b>FB 3EPK863</b>	43	
<b>OUTLANDER III (GG_W, GF_W, ZJ)</b>							
2.2 DI-D; 2.2 DI-D 4WD	08.12-	4N14; (110kW)		WP	<b>FB 3EPK863</b>	43	
<b>PAJERO I Canvas Top (L04_G)</b>							
2.6	01.83-11.90	4G54; (76kW)			<b>FB 13X750</b>	43	
<b>PAJERO III (V7_W, V6_W)</b>							
3.5	04.00-01.07	6G74 (DOHC 24V); (149kW)			<b>532 0840 10</b>	40	
				WP,  A/C	<b>FB 7PK2418</b>	45	
<b>PAJERO IV (V8_W, V9_W)</b>							
3.8 V6	02.07-	6G75; (182-184kW)			<b>532 0840 10</b>	40	
<b>SANTAMO</b>							
2.0 16V; 2.0 16V 4WD	05.99-12.04	4G63 (DOHC 16V); (102kW)			<b>FB 13X675</b>	43	
<b>SPACE WAGON (D0_V/W)</b>							
2.0 GLX	06.86-05.88	G63B; (62kW)			<b>FB 13X675</b>	43	
<b>STARION (A18_A)</b>							
2.6 Turbo Eci	09.87-06.90	G54B T/C; (114kW)			<b>FB 13X750</b>	43	
<b>NISSAN</b>							
<b>ALMERA TINO (V10)</b>							
1.8	12.02-02.06	QG18DE; (85kW)		A/C	<b>FB 6PK1093</b>	44	

**NISSAN**

<b>CABSTAR (F24M, F24W)</b>						
35.14 DCI 3.0; 35.15 DCI, 45.15 DCI 3.0	09.06-12.13	ZD30; ZD30DDTi; ZD30H HD-5; (101-110kW)			A/C	529 0278 10 39
					A/C	534 0629 10 41
<b>KUBISTAR (X80, X76)</b>						
1.2	08.03-10.09	D7F 764; (44kW)			A/C,  →08.05,	529 0280 10 39
<b>LAUREL (JC32)</b>						
2.8 D	01.85-12.89	RD28; (66kW)				FB 13X1075 42
<b>MICRA I (K10)</b>						
1.0; 1.2	12.82-07.92	MA10S; MA12S; (37-44kW)				FB 3PK630 43
<b>MICRA III (K12)</b>						
160 SR	05.05-06.10	HR16DE; (81kW)			→02.06, A/C	FB 7PK1135 45
<b>MICRA IV (K13)</b>						
1.2	05.10-	HR12DE; (59kW)			←BM K13K, K13T, A/C	529 0274 10 39
					A/C	FB 7PK1093 45
					A/C	FB 7PK1165 45
1.2 DIG-S	04.11-	HR12DDR; (72kW)			WP	FB 3PK798 43
<b>MICRA C+C III (K12)</b>						
1.6 160 SR	08.05-	HR16DE; (81kW)			→02.06, A/C	FB 7PK1135 45
<b>NOTE (E12)</b>						
1.2	06.13-	HR12DE; (59kW)			A/C	FB 7PK1165 45
<b>NP300 NAVARA Pick-up (D23)</b>						
2.3 dCi; 2.3 dCi 4x4	10.15-	YS23DDTi; (140kW)			←BM D23T, D23X	535 0298 10 41
<b>NP300 PICKUP (D22)</b>						
2.5 dCi 4x4	04.08-	YD25DDTi; (98kW)				FB 13X775 43
<b>PATROL III/2 Station Wagon (W260)</b>						
2.8 TD; 3.2 D	08.88-11.95	RD28T; SD33T; (81-85kW)				FB 13X775 43
<b>PATROL GR IV (Y60, GR)</b>						
2.8 TD	09.88-06.97	RD28T; (85kW)				FB 13X775 43
<b>PATROL GR V Wagon (Y61)</b>						
2.8 TdC	10.97-02.00	RD28Ti; (96kW)			2x	FB 13X1075 42
3.0 DTi	05.00-	ZD30DDTi; (116-118kW)			A/C	529 0278 10 39
					A/C	534 0629 10 41
<b>PATROL III/2 Hardtop (K260)</b>						
2.8 TD	05.86-06.90	RD28T; (85kW)			2x	FB 13X1075 42
						FB 13X775 43
3.2 D	08.88-06.90	SD33T; (81kW)				FB 13X775 43
<b>PICK UP (D22)</b>						
2.5 Di 4WD	03.02-04.05	(98kW)				FB 13X775 43
<b>PRAIRIE (M10, NM10)</b>						
1.8 SGL	07.83-10.87	CA18S; (65-66kW)				FB 13X750 43
<b>PRIMERA (P11, WP11, P11)</b>						
1.6 16V	06.96-07.02	GA16DE; QG16DE; (66-78kW)			A/C	FB 6PK1093 44
<b>PRIMERA (P12, P12)</b>						
1.6	03.02-	QG16DE; (78kW)			A/C	FB 6PK1093 44
<b>SERENA (C23)</b>						
2.0 D	11.92-09.01	LD20; (49kW)			→12.94	FB 13X750 43
<b>STANZA (T11, T11)</b>						
1.6; 1.8; 1.8 SGL	08.81-12.85	CA16S; CA18; CA18S; (60-66kW)				FB 13X750 43
<b>SUNNY III Camionnette (Y10)</b>						
1.7 D	11.90-03.00	CD17; (40kW)				FB 13X675 43
<b>URVAN Camionnette (E23)</b>						
2.0	07.81-11.82	H20; (55kW)			A/C	FB 13X1350 42
<b>VANETTE (C22, C22)</b>						
2.0 D	10.86-12.95	LD20; LD20ii; (47-49kW)				FB 13X750 43
<b>VANETTE CARGO Autobus/Autocar (HC 23)</b>						
2.0 D	01.96-05.01	LD20; (49kW)				FB 13X750 43
2.3 D	09.94-05.01	LD23; (55kW)				FB 13X1100 42

**OPEL**

<b>ASTRA F (T92, T92, T92)</b>						
1.7 TDS	12.91-09.98	17 DT (TC4EE1); X 17 DT (TC4EE1); (60kW)			A/C	FB 13X915 43
<b>ASTRA G A trois volumes (T98)</b>						
2.2 DTI	09.02-01.05	Y 22 DTR; (86kW)			A/C	529 0203 10 39





**OPEL**

**ASTRA H / ASTRA H GTC (L08, L70, A04, A04, A04)**

1.9 CDTi; 1.9 CDTi; 1.9 CDTi 16V; 1.9 CDTi 16V	04.04-10.10	Z 19 DTH; Z 19 DTJ; (88-110kW)		→72212298 →75189052 →78104400 →7G	534 0610 10	40
1.9 CDTi	06.04-10.10	Z 19 DT; (88kW)		→72172468 →75189052 →78104400 →7G	534 0610 10	40
1.9 CDTi	09.05-10.10	Z 19 DTL; (74kW)		→72207929 →75189052 →78104400 →7G	534 0610 10	40

**CAMPO (TF0, TF1)**

2.5 D; 2.5 D 4x4	08.91-06.94	4JA1; (56kW)			FB 13X1375	42
------------------	-------------	--------------	--	--	------------	----

**COMBO (71\_)**

1.7 D	07.94-10.01	17 D (4EE1); X 17 D (4EE1); (44kW)		A/C	FB 13X915	43
-------	-------------	------------------------------------	--	-----	-----------	----

**COMBO D (X12, X12)**

1.6 CDTi; 2.0 CDTi	02.12-	A 16 FDH; A 16 FDL; A 20 FD; (66-99kW)			534 0610 10	40
--------------------	--------	---	--	--	-------------	----

**CORSA B (S93, S93)**

1.5 D; 1.5 TD; 1.7 D	03.93-09.00	15 D (4EC1); 15 DT (T4EC1); 17 D (4EE1); X 15 DT (T4EC1); X 17 D (4EE1); (37-49kW)		A/C	FB 13X915	43
----------------------	-------------	--	--	-----	-----------	----

**FRONTERA A (U92) / FRONTERA A Sport (U92)**

2.5 TDS	09.96-10.98	25TDS (VM41B); (85kW)			FB 8PK2188	45
---------	-------------	-----------------------	--	--	------------	----

**FRONTERA B (U99)**

2.2 DTi	10.98-09.02	X 22 DTH; Y 22 DTH; (85-88kW)		A/C	529 0203 10	39
---------	-------------	-------------------------------	--	-----	-------------	----

**SIGNUM (Z03)**

1.8	09.05-	Z 18 XER; (103kW)		A/C;  61000001→	FB 5PK1570	44
1.9 CDTi	04.04-	Z 19 DT; Z 19 DTH; Z 19 DTL; (74-110kW)		→71111927	534 0610 10	40
2.2 DTi 16V	05.03-06.08	Y 22 DTR; (86kW)		A/C	529 0203 10	39

**SINTRA**

2.2 DTi	07.97-04.99	X 22 DTH; (85kW)		A/C	529 0203 10	39
---------	-------------	------------------	--	-----	-------------	----

**VECTRA A (J89, J89)**

1.7 TD	03.90-11.95	17 DT (TC4EE1); X 17 DT (TC4EE1); (60kW)		A/C	FB 13X915	43
--------	-------------	---	--	-----	-----------	----

**VECTRA B (J96, J96, J96)**

1.7 TD	10.95-12.98	X 17 DT (TC4EE1); (60kW)		A/C	FB 13X915	43
2.2 DTi 16V	09.00-07.03	Y 22 DTR; (88-92kW)		A/C	529 0203 10	39

**VECTRA C (Z02, Z02)**

1.6	01.06-	Z 16 XEP; (77kW)		A/C	FB 5PK1570	44
1.6; 1.8	01.06-	Z 16 XEP; Z 18 XER; (77-103kW)		A/C;  61000001→	FB 5PK1570	44
1.9 CDTi	04.04-01.09	Z 19 DT; Z 19 DTH; Z 19 DTL; (74-110kW)		→48999999 →71111927	534 0610 10	40

**VECTRA C GTS (Z02)**

1.6; 1.8	01.06-	Z 16 XEP; Z 18 XER; (77-103kW)		A/C;  61000001→	FB 5PK1570	44
1.9 CDTi	04.04-01.09	Z 19 DT; Z 19 DTH; Z 19 DTL; (74-110kW)		→48999999 →71111927	534 0610 10	40

**ZAFIRA A (F75\_)**

2.2 DTi 16V	01.02-06.05	Y 22 DTR; (86kW)		A/C	529 0203 10	39
-------------	-------------	------------------	--	-----	-------------	----

**ZAFIRA B (A05)**

1.9 CDTi	07.05-	Z 19 DTH; (110kW)		→72212298 →7G150345	534 0610 10	40
1.9 CDTi	07.05-	Z 19 DTL; (74kW)		→72207929 →7G150345	534 0610 10	40
1.9 CDTi	07.05-	Z 19 DT; (88kW)		→72172468 →7G150345	534 0610 10	40

**PEUGEOT**

**106 I (1A, 1C)**

1.0; 1.4	08.91-04.96	CDZ (TU9M); K5A (TU3); (37-51kW)		A/C	FB 10X715	42
----------	-------------	----------------------------------	--	-----	-----------	----

**106 Van (1\_)**

1.0	09.91-03.01	CDY (TU9M); TU9; (33kW)		A/C	FB 10X715	42
-----	-------------	-------------------------	--	-----	-----------	----

**205 I (741A/C)**

1.7 Diesel	08.83-10.87	161A (XUD7); (44kW)		M12	532 0424 10	40
------------	-------------	---------------------	--	-----	-------------	----

**PEUGEOT**

<b>205 I (741A/C)</b>							
1.7 Diesel	08.83-10.87	161A (XUD7); (44kW)		<b>A/C</b>	<b>FB 4PK1230</b>	43	
<b>205 II (20A/C)</b>							
1.4	08.90-07.98	KDX (TU3MC); KDY (TU3M); KDZ (TU3M); TU32; (55kW)		<b>A/C</b>	<b>FB 10X715</b>	42	
1.7 Diesel; 1.8 TD; 1.9 Diesel	07.87-09.98	161A (XUD7); A8B (XUD7TE); DJZ (XUD9Y); (44-57kW)		<b>M12</b>	<b>532 0424 10</b>	40	
				<b>A/C</b>	<b>FB 4PK1230</b>	43	
1.8 XDT	08.90-05.97	XUD7T; (58kW)		<b>M12</b>	<b>532 0424 10</b>	40	
<b>205 Box</b>							
1.1	08.87-07.90	H1B (TU1); (40kW)			<b>FB 10X715</b>	42	
1.7 Diesel	03.94-05.97	161A (XUD7); (44kW)		<b>M12</b>	<b>532 0424 10</b>	40	
1.8 D	02.83-07.90	A9A (XUD7); (44kW)		<b>M12</b>	<b>532 0424 10</b>	40	
				<b>A/C</b>	<b>FB 4PK1230</b>	43	
<b>208</b>							
1.6 BlueHDi 100; 1.6 BlueHDi 120; 1.6 HDi	11.13-	BHX (DV6FC); BHY (DV6FD); BHZ (DV6FC); (73-88kW)		pas pour générateur de démarrage	<b>535 0308 10</b>	41	
<b>208 Camionnette</b>							
1.6 BlueHDi 75	04.15-	BHW (DV6FE); (55kW)		pas pour générateur de démarrage	<b>535 0308 10</b>	41	
<b>301</b>							
1.6 BlueHDi 100	04.14-	(73kW)		pas pour générateur de démarrage	<b>535 0308 10</b>	41	
<b>304 (_04M_)</b>							
1.4 D	10.76-10.79	XL4D; (33kW)		Pompe à vide	<b>FB 10X690</b>	41	
<b>305 II (581M, 581E)</b>							
1.9 D; 1.9 Diesel	10.82-12.88	162 (XUD9); D9A (XUD9); (47-48kW)		<b>M12</b>	<b>532 0424 10</b>	40	
<b>306 3/5 portes (7A, 7C, N3, N5)</b>							
1.6	07.00-05.01	NFZ (TU5JP); (66kW)		<b>A/C</b>	<b>FB 10X715</b>	42	
<b>308 II</b>							
1.6 BlueHDi 100; 1.6 BlueHDi 120; 1.6 HDi / BlueHDi 115; 1.6 HDi 100	09.13-	9HC (DV6C); BHY (DV6FD); BHZ (DV6FC); (73-88kW)		pas pour générateur de démarrage	<b>535 0308 10</b>	41	
<b>309 I (10C, 10A)</b>							
1.9 D	06.86-07.89	162 (XUD9); D9A (XUD9); (47kW)		<b>M12</b>	<b>532 0424 10</b>	40	
				<b>A/C</b>	<b>FB 4PK1230</b>	43	
<b>309 II (3C, 3A)</b>							
1.8 Diesel; 1.8 TD; 1.9 Diesel	07.89-12.93	161A (XUD7); 162 (XUD9); A8B (XUD7TE); D9A (XUD9); DJZ (XUD9Y); (44-57kW)		<b>M12</b>	<b>532 0424 10</b>	40	
				<b>A/C</b>	<b>FB 4PK1230</b>	43	
<b>404</b>							
1.6; 1.6 GT	04.63-12.71	XC6; (48-59kW)			<b>FB 13X1225</b>	42	
<b>405 I (15E, 15B)</b>							
1.4	01.87-07.92	K5A (TU3); (47kW)			<b>FB 10X715</b>	42	
1.8 DT 4x4; 1.8 TD; 1.8 Turbo Diesel; 1.9 D; 1.9 Diesel	03.88-12.92	A8A (XUD7TE); AJZ (XUD7TEY); D9B (XUD9A); DJY (XUD9A); DJZ (XUD9Y); (47-66kW)		<b>A/C, M12</b>	<b>532 0424 10</b>	40	
1.8 GLD	04.90-07.92	(44kW)		<b>A/C, M12, XUD7</b>	<b>532 0424 10</b>	40	
<b>405 II (4B, 4E)</b>							
1.6; 1.8; 2.0; 2.0 16V; 2.0 4x4; 2.0 MI-16; 2.0 T 16 X4; 2.0 X4	08.92-10.96	BDY (XU5M2Z); BDY (XU5M3Z); BDZ (XU5M); BFZ (XU5JP); LFZ (XU7JP); RFT (XU10J4); RFX (XU10J2); RFY (XU10J4Z); RGZ (XU10J4TE/Z); (65-144kW)		<b>A/C</b>	<b>FB 6PK1093</b>	44	
1.9 D	08.92-10.96	DJZ (XUD9Y); (47kW)		<b>A/C</b> , →12.92, M12	<b>532 0424 10</b>	40	
<b>407 (6D_, 6E_)</b>							
2.2 HDi; 2.2 HDi 170	05.06-	4HP (DW12BTED4); 4HT (DW12BTED4); (120-125kW)			<b>544 0112 10</b>	41	
<b>505 (551A)</b>							
2.2 Turbo Injection	01.86-12.87	176X (N9TE); (110kW)		<b>A/C</b>	<b>FB 13X775</b>	43	
2.8 GTI V6	06.86-12.93	154X (ZN3J); (105kW)		<b>A/C</b>	<b>FB 13X1375</b>	42	
<b>508</b>							
1.6 BlueHDi 120; 1.6 HDi	03.14-	BHX (DV6FC); BHZ (DV6FC); (85-88kW)		pas pour générateur de démarrage	<b>535 0308 10</b>	41	
<b>604 (561A_)</b>							
2.7 SL	08.77-05.83	112 (ZM); (100kW)		<b>A/C</b> , →01.78, →6564001	<b>FB 13X1350</b>	42	
				<b>A/C</b>	<b>FB 13X1375</b>	42	
2.7 Tl,STl; 2.8 GTI	08.77-07.87	140 (ZMJ); 154A (ZMJK); (106-110kW)		<b>A/C</b>	<b>FB 13X1375</b>	42	
<b>605 (6B)</b>							
2.1 D; 2.1 TD 12V; 2.1 Turbo Diesel	06.89-09.99	P8C (XUD11BTE); P9A (XUD11A); PHZ (XUD11ATE); (60-80kW)		<b>A/C</b> , AUTOM	<b>FB 5PK768</b>	44	
<b>607 (9D, 9U)</b>							
2.2 HDi	05.06-06.10	4HT (DW12BTED4); (125kW)			<b>544 0112 10</b>	41	



**PEUGEOT**

<b>807 (E)</b>							
2.2 HDi	06.02-	4HT (DW12BTED4); 4HW (DW12ATED4); 4HW (DW12BTED4); 4HW (DW12ETED4); (94-125kW)				544 0112 10	41
<b>2008</b>							
1.6 BlueHDi 100; 1.6 BlueHDi 120; 1.6 BlueHDi 75; 1.6 HDi	07.14-	BHW (DV6FE); BHX (DV6FC); BHY (DV6FD); BHZ (DV6FC); (55-88kW)		pas pour générateur de démarrage		535 0308 10	41
1.6 HDi	03.13-	9HD (DV6CTED); (84kW)		DV6FC, pas pour générateur de démarrage		535 0308 10	41
<b>3008</b>							
1.6 BlueHDi 120	05.14-	BHZ (DV6FC); (88kW)		pas pour générateur de démarrage		535 0308 10	41
<b>3008 SUV</b>							
1.6 BlueHDi 120	05.16-	BHZ (DV6FC); (88kW)		pas pour générateur de démarrage		535 0308 10	41
<b>4007 (GP_)</b>							
2.2 HDi	02.07-	4HK (DW12MTED4); 4HN (DW12MTED4); (115kW)				544 0112 10	41
<b>4008</b>							
1.8 HDi; 1.8 HDi AWC	05.12-	6HZ (4N13); (110kW)		WP		FB 3EPK863	43
<b>5008</b>							
1.6 BlueHDi 120	05.14-	BHZ (DV6FC); (88kW)		pas pour générateur de démarrage		535 0308 10	41
<b>Boxer I (230L, 230P, ZCT_)</b>							
1.9 TD; 2.0 4x4	07.94-04.02	D8C (XUD9UTF); RFW (XU10J2); XUD9TE; (68-80kW)		→12.96		FB 10X715	42
2.0 i; 2.0 i 4x4	03.94-04.02	RFW (XU10J2); (80kW)		A/C		FB 6PK1093	44
<b>EXPERT Camionnette</b>							
1.6 BlueHDi 115; 1.6 BlueHDi 95	04.16-	BHV (DV6FDU); BHX (DV6FC); (70-85kW)		pas pour générateur de démarrage		535 0308 10	41
<b>PARTNER</b>							
1.6 BlueHDi 100; 1.6 BlueHDi 120; 1.6 HDi / BlueHDi 75	12.14-	9HK (DV6ETEDM); BHW (DV6FE); BHY (DV6FD); BHZ (DV6FC); (55-88kW)		pas pour générateur de démarrage		535 0308 10	41
1.6 HDi / BlueHDi 75	01.14-	9HK (DV6ETEDM); 9HN (DV6ETED); BHW (DV6FE); (55kW)		pas pour générateur de démarrage, DV6FE		535 0308 10	41
<b>TRAVELLER</b>							
1.6 BlueHDi 115; 1.6 BlueHDi 95	04.16-	(70-85kW)		DV6FCU, DV6FDU, pas pour générateur de démarrage		535 0308 10	41

**PORSCHE**

<b>911 / 911, Targa, Cabriolet</b>							
2.0 E; 2.0 S; 2.0 T; 2.2 E; 2.2 S; 2.2 T; 2.3 E; 2.3 T; 2.7; 2.7 S; 2.7 S Carrera; 2.7 SC Carrera RS; 3.0 SC; 3.0 SC Carrera	07.66-10.83	901.02; 901.03; 901.08; 901.09; 901.10; 901.11; 901.13; 911.01; 911.02; 911.03; 911.04; 911.06; 911.07; 911.08; 911.41; 911.42; 911.43; 911.46; 911.47; 911.48; 911.51; 911.52; 911.57; 911.61; 911.62; 911.67; 911.81; 911.82; 911.83; 911.84; 911.85; 911.86; 911.89; 911.90; 911.91; 911.92; 911.93; 911.94; 911.96; 911.97; 911.98; 911.99; 930.02; 930.03; 930.09; 930.10; 930.12; 930.13; 930.19; (81-154kW)		A/C		FB 13X1100	42
<b>911 (964, 964)</b>							
3.6 Carrera; 3.6 Carrera 4; 3.6 Carrera RS	12.88-05.94	M 64.01; M 64.02; M 64.03; (184-191kW)				FB 13X1075	42
<b>911 (993, 993)</b>							
3.6 Carrera; 3.6 Carrera 4; 3.6 Turbo 4	10.93-09.97	M 64.05; M 64.06; M 64.07; M 64.08; M 64.21; M 64.22; M 64.23; M 64.24; M 64.60; (200-300kW)				FB 13X1075	42
<b>914</b>							
/6 2.0; 1.7	01.69-12.73	901.36; 901.37; W; (59-81kW)				FB 10X965	42
1.8	08.73-02.76	AN; (63kW)		FAN		FB 10X965	42
<b>928</b>							
4.7 S	09.79-07.83	M 28.11; M 28.12; (221kW)		A/C,  01.83 →,  Sport		FB 13X1075	42
4.7 S; 5.0 GT; 5.0 S; 5.0 S,S4; 5.0 S4 Cat	08.83-07.91	M 28.21; M 28.22; M 28.41; M 28.42; M 28.45; M 28.46; M 28.47; (212-243kW)		A/C,  Sport		FB 13X1075	42
5.4 GTS	08.91-11.95	M 28.49; M 28.50; (257kW)		A/C		FB 13X1075	42

**RENAULT**

<b>19 I (S53_, L53_, B/C53_)</b>							
1.4	01.88-12.92	E6J 700; E6J 701; (59kW)		A/C		FB 10X690	41
1.4	01.88-12.92	E6J 700; (59kW)		A/C		FB 10X690	41



**RENAULT**
**19 I (S53, L53, B/C53)**

1.4	07.88-08.90	E6J 700; E6J 701; (57kW)			FB 10X690	41
1.4; 1.4 Cat	07.88-04.92	C2J 772; C3J 710; (43kW)			FB 10X690	41

**19 II (L53, S53, B/C53)**

1.4	01.92-12.95	E6J 700; E7J 706; (59kW)			FB 10X690	41
1.4	01.92-12.95	E7J 742; (55kW)			FB 10X690	41
1.4	11.93-12.95	E7J 742; (55kW)			FB 10X690	41

**25 (B29)**

2.7 V6 Injection	04.84-08.89	Z7V 708; Z7V 709; Z7V 711; (104kW)		A/C,	FB 13X915	43
------------------	-------------	------------------------------------	--	------	-----------	----

**CLIO I (S57, B/C57, 5/357)**

1.2; 1.4	05.90-09.98	E5F 710; E7F 700; E7F 706; E7F 708; E7F 750; E7J 601; E7J 710; E7J 711; E7J 718; E7J 719; E7J 754; E7J 756; E7J 757; (40-59kW)			FB 10X690	41
----------	-------------	--	--	--	-----------	----

**CLIO II (SB0/1/2, BB0/1/2, CB0/1/2)**

1.2	09.98-	D7F 710; D7F 720; D7F 722; D7F 726; D7F 746; D7F 764; D7F 766; (43kW)		A/C, A/C, 	529 0280 10	39
1.2; 1.2 LPG	09.98-06.09	D7F 722; D7F 726; D7F 746; D7F 764; D7F 766; (43-44kW)		A/C,	529 0280 10	39
1.2	09.98-	D7F 720; D7F 726; D7F 746; (43kW)		A/C,	529 0280 10	39
1.2 16V	06.01-	D4F 706; D4F 712; D4F 714; D4F 722; D4F 728; (55kW)		A/C,	529 0280 10	39
1.2 LPG	03.99-05.01	D7F 722; (44kW)		A/C,	529 0280 10	39

**CLIO III (BR0/1, CR0/1)**

2.0 16V Sport	02.06-	F4R 830; (145kW)				529 0283 10	40
						FB 7PK1135	45
2.0 16V Sport	09.08-	F4R 830; (148kW)				529 0283 10	40
						FB 7PK1135	45

**KANGOO I (FC0/1, KC0/1)**

1.2	08.97-	D7F 710; D7F 720; D7F 722; D7F 726; D7F 744; D7F 746; (43kW)		A/C, A/C, 	529 0280 10	39
1.2	07.98-07.01	D7F 764; D7F 766; (44kW)		A/C,	529 0280 10	39
1.2	08.97-	D7F 710; D7F 720; D7F 722; D7F 726; D7F 744; D7F 746; (43kW)		A/C,	529 0280 10	39
1.2 16V	10.01-	D4F 712; D4F 714; D4F 730; (55kW)		A/C, A/C, 	529 0280 10	39
1.2 16V	06.01-	D4F 712; D4F 714; D4F 716; D4F 730; (55kW)		A/C,	529 0280 10	39

**THALIA I (LB0/1/2)**

1.2 16V	04.02-	D4F 706; D4F 712; (55kW)		A/C, A/C, 	529 0280 10	39
---------	--------	--------------------------	--	------------------	-------------	----

**TWINGO (S06, C06)**

1.2	05.96-06.07	D7F 700; D7F 701; D7F 702; D7F 703; D7F 704; D7F 706; (40-43kW)		A/C,	529 0280 10	39
1.2 LPG	10.03-06.07	D7F 702; D7F 708; (44kW)		A/C,	529 0280 10	39

**TWINGO III (BCM)**

0.9 TCe 110; 0.9 TCe 90; 1.0 S Ce 70	09.14-	H4B 401; H4D 400; (52-80kW)			FB 7PK1240	45
--------------------------------------	--------	-----------------------------	--	--	------------	----

**ROVER**
**200 3/5 portes (XW)**

218 D; 218 TD	09.91-10.95	XUD 7TE; XUD9; (52-65kW)			FB 10X715	42
---------------	-------------	--------------------------	--	--	-----------	----

**400 (XW, XW)**

1.8 TD; 418 D; 418 TD	09.91-11.98	XUD 7TE; XUD9; (49-65kW)			FB 10X715	42
-----------------------	-------------	--------------------------	--	--	-----------	----

**800 (XS, XS)**

825 SI/Sterling; 825 SI/Sterling Catalytic-Conv; 827 24V; 827 24V I/SI Cat; 827 SI/Sterling; 827 SI/Sterling Catalytic-Conv; 827 Vitesse/SLI; 827 Vitesse Catalytic-Conv	10.86-02.99	C 25 A1; C 25 A2; C 27 A1; C 27 A2; (110-130kW)		A/C	FB 4PK910	44
--	-------------	---	--	-----	-----------	----

**ROVER****2000-3500 3/5 portes (SD1)**

2600; 2600 S; 3500	06.76-10.86	12 C; 13 C; 38 A; 39 A; (93-115kW)		A/C	FB 13X1075	42
--------------------	-------------	------------------------------------	--	-----	------------	----

**SAAB****9-3 (YS3D, YS3D)**

2.0 i; 2.0 SE Turbo; 2.0 Turbo; 2.3 i; 2.3 Turbo	02.98-08.03	B204E; B204I; B204L; B204R; B205E; B205L; B205R; B234I; B235R; (96-165kW)		A/C	FB 6PK2345	45
--	-------------	---	--	-----	------------	----

2.2 TiD	02.98-09.02	D223L; X 22 DTH; (85-92kW)		A/C	529 0203 10	39
---------	-------------	----------------------------	--	-----	-------------	----

**9-3 (YS3F, YS3F)**

1.9 TiD; 1.9 TTiD	09.04-02.15	A 19 DTR; Z 19 DT; Z 19 DTH; Z 19 DTR; (88-132kW)		A/C	534 0610 10	40
-------------------	-------------	---	--	-----	-------------	----

2.2 TiD	09.02-02.15	D223L; (92kW)		A/C	529 0203 10	39
---------	-------------	---------------	--	-----	-------------	----

**9-3 Break (YS3F)**

1.9 TiD; 1.9 TTiD	03.05-02.15	A 19 DTR; Z 19 DT; Z 19 DTH; Z 19 DTR; (88-132kW)		A/C	534 0610 10	40
-------------------	-------------	---	--	-----	-------------	----

**9-3X**

1.9 TTiD	02.09-12.12	A 19 DTR; Z 19 DTR; (132kW)		A/C	534 0610 10	40
----------	-------------	-----------------------------	--	-----	-------------	----

**9-5 (YS3E, YS3E)**

1.9 TiD	01.06-12.09	Z 19 DTH; (110kW)		A/C	534 0610 10	40
---------	-------------	-------------------	--	-----	-------------	----

2.2 TiD	03.02-12.09	D223L; (88kW)		A/C	529 0203 10	39
---------	-------------	---------------	--	-----	-------------	----

**SEAT****133**

0.8	05.74-11.79	DG; (25kW)		FAN, 01.75→	FB 10X690	41
-----	-------------	------------	--	-------------	-----------	----

**ALHAMBRA (7V8, 7V9)**

2.0 i	04.96-03.10	ADY; ATM; (85kW)		A/C, ADY	FB 11.5X755	42
-------	-------------	------------------	--	----------	-------------	----

**CORDOBA (6K1, 6K2)**

1.6 i; 1.8 i; 1.8 i 16V; 2.0 i; 2.0 i 16V	02.93-10.99	1F; 2E; ABF; ABS; ACC; ADL; ADZ; AFT; AGG; AKL; (55-110kW)		A/C	FB 11.5X755	42
---	-------------	--	--	-----	-------------	----

**CORDOBA Vario (6K5)**

1.6 i	09.96-06.99	1F; AFT; (55-74kW)		A/C	FB 11.5X755	42
-------	-------------	--------------------	--	-----	-------------	----

**CORDOBA (6L2)**

1.9 SDI	09.02-11.09	ASY; (47kW)		A/C	FB 6PK1093	44
---------	-------------	-------------	--	-----	------------	----

**IBIZA II (6K1)**

1.6 i; 1.8 i; 1.8 i 16V; 2.0 i	03.93-02.02	1F; 2E; ABS; ACC; ADL; ADZ; AEH; AFT; AGG; AKL; APF; AUR; (55-95kW)		A/C	FB 11.5X755	42
--------------------------------	-------------	---	--	-----	-------------	----

**IBIZA III (6L1)**

1.9 SDI	02.02-12.05	ASY; (47kW)		A/C	FB 6PK1093	44
---------	-------------	-------------	--	-----	------------	----

**INCA (6K9)**

1.6 i	11.95-05.98	1F; (55kW)		A/C	FB 11.5X755	42
-------	-------------	------------	--	-----	-------------	----

**LEON (1M1)**

2.8; 2.8 Cupra 4	02.01-06.06	AUE; BDE; (150kW)		A/C	FB 6PK1264	44
------------------	-------------	-------------------	--	-----	------------	----

**RONDA (022A)**

1.6	08.83-09.85	022 A 000; 138 AR6.000; (68kW)		A/C	FB 13X775	43
-----	-------------	--------------------------------	--	-----	-----------	----

**TOLEDO I (1L)**

1.6 i	05.91-03.99	1F; (52-55kW)		A/C	1L-ZD304851→	42
-------	-------------	---------------	--	-----	--------------	----

1.6 i; 1.8 i; 2.0 i 16V	11.93-03.99	ABF; ABS; ACC; ADZ; AFT; (66-110kW)		A/C	FB 11.5X755	42
-------------------------	-------------	-------------------------------------	--	-----	-------------	----

**TOLEDO II (1M2)**

2.3 V5 20V	09.00-11.03	AQN; (125kW)		A/C	FB 6PK1264	44
------------	-------------	--------------	--	-----	------------	----

**SKODA****FABIA (6Y5, 6Y2, 6Y3)**

1.9 SDI	11.99-03.08	ASY; (47kW)		A/C	FB 6PK1093	44
---------	-------------	-------------	--	-----	------------	----

**FABIA I Praktik (6Y5)**

1.9 SDI	07.01-12.07	ASY; (47kW)		A/C	FB 6PK1093	44
---------	-------------	-------------	--	-----	------------	----

**SMART****CABRIO (450)**

0.8 CDI	03.01-01.04	OM 660.940; OM 660 DE 8LA; (30kW)			FB 5PK768	44
---------	-------------	-----------------------------------	--	--	-----------	----

**CITY-COUPE (450)**

0.8 CDI	11.99-01.04	OM 660.940; OM 660 DE 8LA; (30kW)			FB 5PK768	44
---------	-------------	-----------------------------------	--	--	-----------	----

**FORFOUR 3/5 portes (453)**

0.9; 0.9 Brabus; 1.0	07.14-	H4B 409; H4DA401; M 281.910; M 281.920; (45-80kW)		A/C	FB 7PK1240	45
----------------------	--------	---	--	-----	------------	----

**FORTWO Décapotable (453)**

0.9; 0.9 Brabus; 1.0	09.15-	M 281.910; M 281.920; (52-80kW)		A/C	FB 7PK1240	45
----------------------	--------	---------------------------------	--	-----	------------	----

**FORTWO Coupe / Cabrio (450, 450)**

0.8 CDI	01.04-01.07	OM 660.940; OM 660 DE 8LA; (30kW)			FB 5PK768	44
---------	-------------	-----------------------------------	--	--	-----------	----

**SMART**
**FORTWO Coupe / Cabrio (451, 451)**

0.8 CDi	01.07-	OM 660.950; (33kW)		WP	FB 5PK768	44
0.8 CDi	08.09-	OM 660.951; (40kW)			FB 5PK768	44

**FORTWO Coupé (453)**

0.9; 0.9 Brabus; 1.0	07.14-	M 281.910; M 281.920; (45-80kW)		A/C	FB 7PK1240	45
----------------------	--------	---------------------------------	--	-----	------------	----

**SUBARU**
**JUSTY I (KAD)**

1000; 1000 4WD	11.84-10.95	EF10; (37-40kW)		01.89→	FB 10X690	41
----------------	-------------	-----------------	--	--------	-----------	----

**LEGACY V Break (BR)**

2.0 i AWD; 2.5 i AWD	06.12-12.14	FB20; FB25; (110-127kW)		08.14→	535 0316 10	41
----------------------	-------------	-------------------------	--	--------	-------------	----

**LEONE I (AB) / LEONE I Break / LEONE I Hatchback / LEONE II / LEONE II Break**

1800 4WD; 1800 Super 4WD; 1800 Super Turbo 4WD; 1800 Turbo 4WD; 1800 Turismo 4WD	09.80-07.91	EA81; EA82; EA82T; (59-100kW)		A/C	FB 13X1100	42
--	-------------	-------------------------------	--	-----	------------	----

**VANILLE Autobus/Autocar (E10, E12)**

1.2 i 4WD	08.91-02.00	EF12; (40kW)			FB 10X715	42
-----------	-------------	--------------	--	--	-----------	----

**OUTBACK (BR)**

2.5 i AWD	01.13-	FB25B; (127kW)		08.14→	535 0316 10	41
-----------	--------	----------------	--	--------	-------------	----

**OUTBACK (BS)**

2.5 AWD	03.15-	FB25; (129kW)			535 0316 10	41
---------	--------	---------------	--	--	-------------	----

**XT Coupé (XT)**

1.8 Turbo 4WD	11.84-12.90	EA82T; (96-100kW)		A/C	FB 13X1100	42
---------------	-------------	-------------------	--	-----	------------	----

**XV**

2.0 i AWD	03.12-	FB20B; (110kW)		01.15→	535 0316 10	41
-----------	--------	----------------	--	--------	-------------	----

**SUZUKI**
**SX4 (EY, GY)**

1.9 DDiS; 1.9 DDiS 4x4; 2.0 DDiS; 2.0 DDiS 4x4	06.06-	D19AA; D20AA; (88-99kW)			534 0610 10	40
--	--------	-------------------------	--	--	-------------	----

**TALBOT**
**SIMCA 1000 / SIMCA 1200 S Coupé**

0.9; 1.2; 1.3 Rallye 2; 1005 LS, GLS; 1006 SR, GLS	10.61-07.78	1D1; 1G4; 353S; 354; 3E1; (29-63kW)			FB 13X1075	42
--	-------------	-------------------------------------	--	--	------------	----

**SIMCA 1300 / SIMCA 1301**

1.3; 1.3 Spezial	08.63-07.72	345/S; (38-51kW)		WP, FAN	FB 13X775	43
------------------	-------------	------------------	--	---------	-----------	----

**TAGORA**

2.6	08.81-10.83	9L6; (122kW)		A/C	FB 13X1375	42
-----	-------------	--------------	--	-----	------------	----

**TOYOTA**
**AURIS (\_E18\_)**

1.4 D-4D	10.12-	1ND-TV; (66kW)			535 0303 10	41
----------	--------	----------------	--	--	-------------	----

**AURIS TOURING SPORTS (\_E18\_)**

1.4 D-4D	07.13-	1ND-TV; (66kW)			535 0303 10	41
----------	--------	----------------	--	--	-------------	----

**AVENSIS T22 (\_T22\_, \_T22\_, \_T22\_)**

1.6; 1.8	09.97-10.00	4A-FE; 7A-FE; (74-81kW)			FB 3PK630	43
2.0; 2.0 VVT-i	10.00-02.03	1AZ-FSE; (110kW)		A/C	FB 7PK1593	45

**AVENSIS VERSO (\_M2\_)**

2.0	08.01-11.09	1AZ-FE; (110kW)		→09.03, A/C	FB 7PK1593	45
-----	-------------	-----------------	--	-------------	------------	----

**CARINA II (\_T15\_)**

1.6	10.83-11.87	4A-L; 4A-LC; (55-63kW)			FB 3PK630	43
-----	-------------	------------------------	--	--	-----------	----

**CARINA II (\_T17\_, \_T17\_, \_T17\_)**

1.6	12.87-03.92	4A-F; 4A-FE; (66-75kW)			FB 3PK630	43
-----	-------------	------------------------	--	--	-----------	----

**CARINA II A trois volumes (\_T15\_)**

1.6	10.83-11.87	4A-L; 4A-LC; (55-62kW)			FB 3PK630	43
-----	-------------	------------------------	--	--	-----------	----

**CARINA E (\_T19\_, \_T19\_, \_T19\_)**

1.6; 1.6 16V; 1.6 GLi; 1.6 i; 1.8; 1.8 i; 1.8 i 16V	04.92-09.97	4A-FE; 7A-FE; (73-85kW)			FB 3PK630	43
---	-------------	-------------------------	--	--	-----------	----

**CELICA (\_T16\_)**

1.6	04.86-08.89	4A-L; (63kW)			FB 3PK630	43
-----	-------------	--------------	--	--	-----------	----

**CELICA Coupé (\_T18\_)**

1.6	10.89-11.93	4A-FE; (77kW)			FB 3PK630	43
-----	-------------	---------------	--	--	-----------	----

**CELICA (\_T20\_)**

1.8 i 16V	11.93-11.99	7A-FE; (85kW)			FB 3PK630	43
-----------	-------------	---------------	--	--	-----------	----

**CELICA 3/5 portes (\_T16\_)**

1.6	04.86-08.89	4A-L; (63kW)			FB 3PK630	43
-----	-------------	--------------	--	--	-----------	----





**TOYOTA**

**COROLLA ( \_E8\_ , \_E8\_ )**

1.6	06.83-05.88	4A-L; (62-63kW)			FB 3PK630	43
-----	-------------	-----------------	--	--	-----------	----

**COROLLA ( \_E9\_ , \_E9\_ , \_E9\_ , \_E9\_ )**

1.6; 1.6 i; 1.6 i 4WD; 1.6 XLI; 1.6 XLI 4WD	08.87-06.93	4A-F; 4A-FE; (66-77kW)			FB 3PK630	43
---	-------------	------------------------	--	--	-----------	----

**COROLLA ( \_E10\_ , \_E10\_ , \_E10\_ , \_E10\_ )**

1.6; 1.6 GLi; 1.6 Si; 1.8 16V 4WD; 1.8 GT	05.92-04.97	4A-FE; 7A-FE; (81-86kW)			FB 3PK630	43
---	-------------	-------------------------	--	--	-----------	----

**COROLLA ( \_E11\_ , \_E11\_ , \_E11\_ , \_E11\_ )**

1.6; 1.6 Aut.; 1.8 4WD	04.97-10.01	4A-FE; 7A-FE; (79-81kW)			FB 3PK630	43
------------------------	-------------	-------------------------	--	--	-----------	----

**COROLLA A trois volumes ( \_E18\_ , \_ZRE17\_ )**

1.4 D-4D	06.13-	1ND-TV; (66kW)			535 0303 10	41
----------	--------	----------------	--	--	-------------	----

**CROWN A trois volumes ( \_S1\_ ) / CROWN Station Wagon ( \_S1\_ )**

2.8; 2.8 Si	04.80-09.83	5M; 5M-E; (107kW)			FB 13X1225	42
-------------	-------------	-------------------	--	--	------------	----

2.8 i Super Saloon	02.84-03.85	5M-GE; (125kW)		A/C	FB 13X1400	43
--------------------	-------------	----------------	--	-----	------------	----

**DYNA Camion plate-forme/Châssis ( \_KD\_ , \_LY\_ , \_Y2\_ , \_U3\_ , \_U4\_ )**

3.0 D4d	09.06-	1KD-FTV; (80kW)		A/C	FB 7PK1093	45
---------	--------	-----------------	--	-----	------------	----

**HIACE IV ( \_H1\_ , \_H2\_ , \_LXH1\_ , \_RZH1\_ , \_LH1\_ )**

2.4 D; 2.4 TD; 2.4 TD 4WD	08.95-08.06	2L; 2L-T; (55-66kW)		A/C	FB 13X1225	42
---------------------------	-------------	---------------------	--	-----	------------	----

2.5 D-4D; 2.5 D-4D 4WD	11.01-08.06	2KD-FTV; (65-75kW)		A/C	FB 7PK1093	45
------------------------	-------------	--------------------	--	-----	------------	----

**HILUX VII Pick-up ( \_N1\_ , \_N2\_ , \_N3\_ )**

2.5 D-4D; 2.5 D-4D 4WD; 2.5 D 4WD; 3.0 D-4D 4WD	10.05-	1KD-FTV; 2KD-FTV; (75-126kW)		A/C	FB 7PK1093	45
---	--------	------------------------------	--	-----	------------	----

**HILUX VI Pick-up ( \_N1\_ )**

2.5 D-4D; 2.5 D-4D 4WD	11.01-07.05	2KD-FTV; (65-75kW)		A/C	FB 7PK1093	45
------------------------	-------------	--------------------	--	-----	------------	----

**LAND CRUISER ( \_J4\_ , \_J5\_ , \_J4\_ )**

4.2	01.75-04.86	2F; (89kW)		→08.80	FB 13X1075	42
-----	-------------	------------	--	--------	------------	----

4.2	01.75-04.86	2F; (89kW)		→07.80	FB 13X1075	42
-----	-------------	------------	--	--------	------------	----

**LAND CRUISER ( \_J6\_ )**

4.0 Diesel	10.81-01.88	2H; (74-77kW)		A/C,  11.84→, →10.85	FB 13X1375	42
------------	-------------	---------------	--	----------------------	------------	----

				A/C,  →10.84	FB 13X1400	43
--	--	--	--	--------------	------------	----

				A/C,  11.85→		
--	--	--	--	--------------	--	--

4.0 Diesel	01.85-12.87	2H; (76kW)		A/C,  →10.85	FB 13X1375	42
------------	-------------	------------	--	--------------	------------	----

				A/C,  10.85→	FB 13X1400	43
--	--	--	--	--------------	------------	----

4.0 Turbo-D	10.85-12.89	12HT; (100kW)		A/C	FB 13X1400	43
-------------	-------------	---------------	--	-----	------------	----

**PREVIA ( \_R3\_ )**

2.4	08.00-01.06	2AZ-FE; (115kW)		A/C	FB 7PK1593	45
-----	-------------	-----------------	--	-----	------------	----

**PROACE Autobus/Autocar ( \_MPY\_ ) / PROACE Camionnette ( \_MDZ\_ )**

1.6 D	02.16-	3WZ-HV; 3WZ-TV; (70-85kW)		pas pour générateur de démarrage	535 0308 10	41
-------	--------	---------------------------	--	----------------------------------	-------------	----

**RAV 4 II ( \_A2\_ )**

2.0 4WD	06.00-11.05	1AZ-FE; (110kW)		A/C	FB 7PK1593	45
---------	-------------	-----------------	--	-----	------------	----

**RAV 4 III ( \_A3\_ )**

2.0 4WD	03.06-	1AZ-FE; (112kW)		A/C	FB 7PK1593	45
---------	--------	-----------------	--	-----	------------	----

**YARIS ( \_P13\_ )**

1.4 D	09.11-	1ND-TV; (66kW)			535 0303 10	41
-------	--------	----------------	--	--	-------------	----

**VAUXHALL**

**ASTRA Mk V (H) TwinTop, (H) Sport Hatch**

1.9 CDTi	08.05-11.10	Z 19 DTL; (74kW)		→72207929	534 0610 10	40
----------	-------------	------------------	--	-----------	-------------	----

				→75189052
--	--	--	--	-----------

				→78104400
--	--	--	--	-----------

				→7G
--	--	--	--	-----

1.9 CDTi	01.06-11.10	Z 19 DTH; (110kW)		→72212298	534 0610 10	40
----------	-------------	-------------------	--	-----------	-------------	----

				→75189052
--	--	--	--	-----------

				→78104400
--	--	--	--	-----------

				→7G
--	--	--	--	-----

**VOLVO**

**240 (P245, P242, P244)**

2.0	08.76-12.93	B 19 A; B 200 E; B 200 F; B 200 K; (66-89kW)		A/C,  # OE 958493, OE 967114	FB 13X1075	42
-----	-------------	--	--	------------------------------	------------	----

				A/C,  # OE 958504, 967133	FB 13X1350	42
--	--	--	--	---------------------------	------------	----

2.1	08.80-07.84	B 21 A; (79kW)		A/C,  115350→	FB 13X1075	42
-----	-------------	----------------	--	---------------	------------	----

2.3; 2.3 i Cat	08.78-07.93	B 230 A; B 230 E; B 230 F; B 23 A; B 23 E; (81-103kW)		A/C,	FB 13X1075	42
----------------	-------------	---	--	------	------------	----

2.4 Diesel	08.78-08.93	D 24; (58-60kW)		A/C	FB 13X915	43
------------	-------------	-----------------	--	-----	-----------	----

2.8	10.82-09.84	B 28 E; (114kW)			FB 10X965	42
-----	-------------	-----------------	--	--	-----------	----



## VOLVO

<b>240 (P245, P242, P244)</b>						
2.8	10.82-09.84	B 28 E; (114kW)		A/C	FB 13X1400	43
<b>260 (P262, P264) / 260 Break (P265)</b>						
2.7	08.74-07.82	B 27 A; B 27 E; B 27 F; (92-109kW)		A/C	FB 13X1400	43
<b>740 (745, 744)</b>						
2.3	08.83-07.84	B 23 E; (95kW)			FB 13X1075	42
2.3	08.88-07.90	B 234 F; (114kW)		→250080	FB 13X1075	42
2.3	08.88-08.92	B 234 F; (111kW)			FB 13X1075	42
2.4 Diesel	08.85-07.88	D 24; (60kW)		A/C	FB 13X915	43
<b>760 (704, 765, 704, 764)</b>						
2.3 Turbo	08.82-07.84	B 23 ET; (127kW)			FB 13X1075	42
2.8	08.81-07.88	B 280 E; B 28 E; (115kW)		A/C	FB 13X1400	43
2.8	05.86-08.91	B 280 F; (105-108kW)		A/C,  →12.87	FB 13X1400	43
<b>940 (945, 944)</b>						
2.4 TD Intercooler; 2.4 Turbo Diesel	08.90-12.94	D 24 T; D 24 TIC; (80-90kW)		A/C,  →08.92	FB 13X915	43
<b>S60 I</b>						
2.4 D; 2.4 D5	03.05-04.10	D 5244 T4; D 5244 T7; (93-136kW)		→545224,  →349808,  →349808, A/C	529 0277 10	39
2.4 D5	01.01-04.10	D 5244 T; (120kW)		→08.06,  →545224,  →349808, A/C	529 0277 10	39
<b>S80 I (TS, XY)</b>						
2.4 D5	08.01-07.06	D 5244 T; (120kW)		→545224,  →349808, A/C	529 0277 10	39
<b>S80 II (AS)</b>						
2.4 D; D5; D5 AWD	03.06-	D 5244 T; D 5244 T4; D 5244 T5; (120-136kW)		→545224,  →349808, A/C	529 0277 10	39
<b>S90</b>						
2.9	01.97-05.98	B 6304 G; B 6304 S2; (132-150kW)		A/C,  BM 1997, 1998	FB 6PK1755	44
<b>V70 II (SW)</b>						
2.4 D; 2.4 D5; 2.4 D5 AWD	01.01-12.08	D 5244 T; D 5244 T2; D 5244 T4; D 5244 T5; D 5244 T7; (93-136kW)		Suède, Belgique,  →545224,  →349808, A/C	529 0277 10	39
2.4 D5 AWD	07.05-12.08	D 5244 T4; (136kW)		→545224,  →349808, A/C	529 0277 10	39
<b>V70 III (BW)</b>						
D5; D5 AWD	04.07-12.09	D 5244 T4; (136kW)		→545224,  →349808, A/C	529 0277 10	39
<b>V90 Break</b>						
2.9	01.97-12.98	B 6304 G; B 6304 S2; (132-150kW)		A/C	FB 6PK1755	44
<b>XC60</b>						
D5 AWD	05.08-12.09	D 5244 T4; (136kW)		→545224,  →349808, A/C	529 0277 10	39
<b>XC70 II</b>						
D5 AWD	04.07-12.09	D 5244 T4; (136kW)		→545224,  →349808, A/C	529 0277 10	39
<b>V70 XC</b>						
2.4 D5 AWD; 2.4 D5 XC AWD	09.02-08.07	D 5244 T; D 5244 T4; (120-136kW)		→545224,  →349808, A/C	529 0277 10	39
<b>XC90 I</b>						
D5 AWD	10.02-12.10	D 5244 T; D 5244 T4; D 5244 T5; (120-136kW)		→545224,  →349808, A/C	529 0277 10	39
<b>VW</b>						
<b>411,412</b>						
1.7; 1.8	07.68-03.75	AN; AT; V; W; Z; (50-63kW)			FB 10X965	42
<b>412 Variant</b>						
1.7; 1.8 E,LE	01.72-03.75	AN; AT; W; (55-63kW)			FB 10X965	42
<b>BORA (1J6, 1J2)</b>						
2.3 V5; 2.3 V5 4motion; 2.8 V6 4motion; 2.8 VR6	03.99-05.05	AQN; AQP; AUE; BDE; (125-150kW)			FB 6PK1264	44
<b>CORRADO (53I)</b>						
2.0 i	04.93-12.95	2E; ADY; (85kW)			FB 11.5X755	42
<b>GOLF II (19E, 1G1)</b>						
1.6; 1.8; 1.8 GTI; 1.8 GTI 16V; 1.8 GTI Cat; 1.8 i Cat; 1.8 i Cat Syncro; 1.8 Syncro	08.83-12.92	1P; ABN; DX; EV; EZ; GU; GX; GZ; HM; HV; KR; PB; PF; PL; PN; RD; RF; RH; RP; (51-102kW)			FB 11.2X866	42
1.6 D; 1.6 TD	08.83-10.91	JP; JR; ME; MF; (40-51kW)			FB 10X965	42
1.6 TD	04.89-10.91	RA; SB; (59kW)			FB 10X965	42





**VW**

**GOLF II (19E, 1G1)**

1.6 TD	04.89-10.91	RA; SB; (59kW)			FB 11.2X866	42
--------	-------------	----------------	--	--	-------------	----

**GOLF III (1H5, 1H1)**

1.4; 1.6; 1.8; 1.8 Syncro; 2.0; 2.0 GTI 16V; 2.0 Syncro	10.91-04.99	2E; AAM; ABA; ABD; ABF; ABS; ACC; ADY; ADZ; AEK; AEX; AFT; AGG; AKR; AKS; ANN; ANP; APQ; (40-110kW)		A/C	FB 11.5X755	42
---	-------------	---	--	-----	-------------	----

**GOLF III Cabriolet (1E7)**

1.6; 1.8; 2.0	07.93-05.98	2E; AAM; ABS; ADY; ADZ; AEK; AFT; AGG; AKR; AKS; (55-85kW)		A/C	FB 11.5X755	42
---------------	-------------	--	--	-----	-------------	----

**GOLF IV (1J1, 1J5)**

2.3 V5; 2.3 V5 4motion; 2.8 V6 4motion; 3.2 R32 4motion	03.99-06.06	AQN; AQP; AUE; BDE; BFH; BML; (125-177kW)		A/C	FB 6PK1264	44
---	-------------	---	--	-----	------------	----

**GOLF IV Cabriolet (1E7)**

1.6; 1.8; 2.0	06.98-06.02	AAM; ADZ; AFT; AGG; AKR; AKS; ANN; ANP; ATU; AWF; AWG; (55-85kW)		A/C	FB 11.5X755	42
---------------	-------------	--	--	-----	-------------	----

**MULTIVAN V (7HM, 7HN, 7HF, 7EF, 7EM, 7EN)**

3.2 V6; 3.2 V6 4motion	02.04-11.09	BDL; BKK; CFLA; (170-173kW)		A/C	FB 6PK1264	44
------------------------	-------------	-----------------------------	--	-----	------------	----

**NEW BEETLE (9C1, 1C1)**

2.3 V5	10.00-09.10	AQN; (125kW)		A/C	FB 6PK1264	44
--------	-------------	--------------	--	-----	------------	----

**PASSAT B4 (3A2, 35I, 3A5, 35I)**

1.6	04.88-07.91	1F; ABN; EZ; RF; (53-55kW)			FB 11.2X866	42
1.6; 2.0; 2.0 16V	01.94-05.97	ABF; AEK; AEP; AFT; (74-110kW)		A/C	FB 11.5X755	42
1.6 TD	08.88-09.93	RA; SB; (59kW)			FB 10X965	42
1.8; 2.0; 2.0 Syncro	02.88-05.97	2E; AAM; ABA; ABS; ADY; ADZ; AGG; PB; PF; RP; (55-85kW)		A/C → 31-P-200 000,  31-P-200 001 →	FB 11.2X866 FB 11.5X755	42 42
1.8	02.88-05.97	ABS; ADZ; RP; (66kW)		A/C → 31-P-200 000,  ABS  RP,  A/C	FB 11.2X866	42
1.9 D	05.89-10.93	1Y; (50kW)		A/C → 31-P-200 001 →	FB 11.5X755	42
2.0	02.90-05.97	2E; ADY; AGG; (85kW)		A/C → 31-P-200 000,	FB 11.2X866 FB 11.5X755	42 42

**FLIGHT CLASSIC (6V2)**

100 1.6	12.95-09.01	AEH; AFT; AKL; APF; AUR; (74kW)		A/C,  AFT	FB 11.5X755	42
75 1.6; 90 1.8	11.95-09.01	1F; ABS; ADD; ADZ; (55-66kW)		A/C	FB 11.5X755	42

**POLO Variant (6V5)**

1.6	05.97-09.01	AEH; AFT; AKL; APF; AUR; (74kW)		A/C,  AFT	FB 11.5X755	42
1.8	05.97-09.01	ADZ; (66kW)		A/C	FB 11.5X755	42

**POLO (9N\_)**

1.9 SDI	10.01-11.09	ASY; (47kW)		A/C	FB 6PK1093	44
---------	-------------	-------------	--	-----	------------	----

**POLO A trois volumes (9A4)**

1.9 SDI	09.02-	ASY; (47kW)		A/C	FB 6PK1093	44
---------	--------	-------------	--	-----	------------	----

**SHARAN (7M8, 7M9, 7M6)**

2.0	09.95-03.10	ADY; ATM; (85kW)		A/C,  ADY	FB 11.5X755	42
2.8 V6 24V; 2.8 V6 24V 4motion	04.00-03.10	AYL; (150kW)		A/C	FB 6PK1264	44

**TRANSPORTER II Autobus/Autocar / TRANSPORTER II Camionnette**

1.7	08.71-12.73	CA; CB; (49kW)			FB 10X965	42
1.8; 2.0	11.73-04.79	AP; CJ; GD; GE; (50-51kW)		FAN	FB 10X965	42

**TRANSPORTER T3**

1.6 D; 1.6 TD; 1.7 D	01.81-07.92	CS; JX; KY; (37-51kW)		1re pompe hydraulique,  → 12.85 1er alternateur, 2e pompe hydraulique,  01.86 → 2e alternateur,  01.86 → 2e pompe hydraulique,  01.86 →	FB 13X1225	42
1.6 TD Syncro; 1.7 D	03.86-07.92	JX; KY; (42-51kW)		1er alternateur, 2e alternateur 2e pompe hydraulique	FB 13X1225	42

**TRANSPORTER T4 (70XB, 70XC, 7DB, 7DW, 7DK, 70XD)**

1.8	12.90-07.92	PD; (49kW)			FB 10X965	42
-----	-------------	------------	--	--	-----------	----

**TRANSPORTER T5 (7HB, 7HJ, 7EB, 7EJ, 7EF, 7EG, 7HA, 7HH, 7EA, 7EH)**

3.2 4motion; 3.2 V6; 3.2 V6 4motion	04.03-11.09	BDL; BKK; CFLA; (170-173kW)		A/C	FB 6PK1264	44
-------------------------------------	-------------	-----------------------------	--	-----	------------	----

**TRANSPORTER V Camion plate-forme/Châssis (7JD, 7JE, 7JL, 7JY)**

3.2 V6	08.03-11.09	BDL; BKK; (170-173kW)		A/C	FB 6PK1264	44
--------	-------------	-----------------------	--	-----	------------	----

**VENTO (1H2)**

1.4; 1.6; 1.8; 2.0	11.91-09.98	2E; AAM; ABD; ABS; ACC; ADD; ADY; ADZ; AEK; AEX; AFT; AGG; AKR; (40-85kW)		A/C	FB 11.5X755	42
--------------------	-------------	---	--	-----	-------------	----





## Numerical listing / Liste numérique

529 0150 10	MAZDA	12	FB 11.5X755	SEAT	22	FB 4PK910	HONDA	9
529 0195 10	HYUNDAI	9, 10	FB 11.5X755	VW	25, 26	FB 4PK910	ROVER	21
529 0195 10	KIA	10, 11	FB 11.9X793	FORD	8, 9	FB 5PK675	ALFA ROMEO	3
529 0203 10	OPEL	17, 18	FB 13X1075	DAIMLER	7	FB 5PK675	FORD	8
529 0203 10	SAAB	22	FB 13X1075	JAGUAR	10	FB 5PK675	MAZDA	12
529 0204 10	BMW	4	FB 13X1075	MAZDA	12	FB 5PK768	CITROËN	6
529 0223 10	LANCIA	11	FB 13X1075	MERCEDES-BENZ	15	FB 5PK768	PEUGEOT	19
529 0274 10	NISSAN	17	FB 13X1075	NISSAN	17	FB 5PK768	SMART	22, 23
529 0275 10	MAZDA	12	FB 13X1075	PORSCHE	20	FB 3EPK863	CITROËN	6
529 0277 10	VOLVO	25	FB 13X1075	ROVER	22	FB 3EPK863	MITSUBISHI	16
529 0278 10	NISSAN	17	FB 13X1075	TALBOT	23	FB 3EPK863	PEUGEOT	20
529 0280 10	DACIA	7	FB 13X1075	TOYOTA	24	FB 4PK1230	CITROËN	6
529 0280 10	NISSAN	17	FB 13X1075	VOLVO	24, 25	FB 4PK1230	LADA	11
529 0280 10	RENAULT	21	FB 13X1100	ALFA ROMEO	3	FB 4PK1230	PEUGEOT	19
529 0281 10	FORD	8, 9	FB 13X1100	FORD	8	FB 5PK1570	CHEVROLET	5
529 0283 10	RENAULT	21	FB 13X1100	NISSAN	17	FB 5PK1570	LANCIA	11
532 0424 10	CITROËN	6	FB 13X1100	PORSCHE	20	FB 5PK1570	OPEL	18
532 0424 10	PEUGEOT	18, 19	FB 13X1100	SUBARU	23	FB 5PK1585	FIAT	7
532 0804 10	BMW	4, 5	FB 13X1225	FORD	9	FB 5PK1585	LANCIA	11
532 0804 10	MINI	16	FB 13X1225	LANCIA	11	FB 6PK1093	CITROËN	6, 7
532 0824 10	LAND ROVER	12	FB 13X1225	PEUGEOT	19	FB 6PK1093	NISSAN	16, 17
532 0840 10	MITSUBISHI	16	FB 13X1225	TOYOTA	24	FB 6PK1093	PEUGEOT	19, 20
532 0866 10	MERCEDES-BENZ	13, 14, 15, 16	FB 13X1225	VW	26	FB 6PK1093	SEAT	22
534 0586 10	HONDA	9	FB 13X1350	LAND ROVER	12	FB 6PK1093	SKODA	22
534 0610 10	ALFA ROMEO	3	FB 13X1350	MERCEDES-BENZ	12, 13, 14	FB 6PK1093	VW	26
534 0610 10	CADILLAC	5	FB 13X1350	NISSAN	17	FB 6PK1264	AUDI	3, 4
534 0610 10	FIAT	7, 8	FB 13X1350	PEUGEOT	19	FB 6PK1264	SEAT	22
534 0610 10	LANCIA	11	FB 13X1350	VOLVO	24	FB 6PK1264	VW	25, 26
534 0610 10	OPEL	18	FB 13X1375	MERCEDES-BENZ	12, 13	FB 6PK1755	FORD	9
534 0610 10	SAAB	22	FB 13X1375	OPEL	18	FB 6PK1755	JEEP	10
534 0610 10	SUZUKI	23	FB 13X1375	PEUGEOT	19	FB 6PK1755	VOLVO	25
534 0610 10	Vauxhall	24	FB 13X1375	TALBOT	23	FB 6PK1955	FORD	9
534 0627 10	BMW	4, 5	FB 13X1375	TOYOTA	24	FB 6PK2090	BMW	4
534 0629 10	NISSAN	17	FB 13X1400	HYUNDAI	10	FB 6PK2345	CHEVROLET	5
535 0298 10	NISSAN	17	FB 13X1400	LANCIA	11	FB 6PK2345	SAAB	22
535 0303 10	TOYOTA	23, 24	FB 13X1400	TOYOTA	24	FB 7PK1093	NISSAN	17
535 0308 10	CITROËN	5, 6	FB 13X1400	VOLVO	25	FB 7PK1093	TOYOTA	24
535 0308 10	DS	7	FB 13X675	HYUNDAI	9, 10	FB 7PK1135	NISSAN	17
535 0308 10	PEUGEOT	19, 20	FB 13X675	KIA	10, 11	FB 7PK1135	RENAULT	21
535 0308 10	TOYOTA	24	FB 13X675	MITSUBISHI	16	FB 7PK1165	NISSAN	17
535 0316 10	SUBARU	23	FB 13X675	NISSAN	17	FB 7PK1240	RENAULT	21
535 0328 10	MERCEDES-BENZ	13, 14, 15	FB 13X750	ALFA ROMEO	3	FB 7PK1240	SMART	22, 23
544 0111 10	MERCEDES-BENZ	13, 14, 15, 16	FB 13X750	FIAT	7, 8	FB 7PK1593	LAND ROVER	12
544 0112 10	CITROËN	6	FB 13X750	HYUNDAI	10	FB 7PK1593	TOYOTA	23, 24
544 0112 10	FIAT	8	FB 13X750	IVECO	10	FB 7PK2418	MERCEDES-BENZ	13, 14, 15
544 0112 10	FORD	9	FB 13X750	JAGUAR	10	FB 7PK2418	MITSUBISHI	16
544 0112 10	LANCIA	11	FB 13X750	LANCIA	11	FB 8PK1478	BMW	5
544 0112 10	LAND ROVER	12	FB 13X750	LAND ROVER	12	FB 8PK2188	JEEP	10
544 0112 10	PEUGEOT	19, 20	FB 13X750	MERCEDES-BENZ	12, 13, 14, 15	FB 8PK2188	OPEL	18
FB 10X690	AUDI	3	FB 13X750	MITSUBISHI	16			
FB 10X690	FIAT	7, 8	FB 13X750	NISSAN	17			
FB 10X690	FORD	8, 9	FB 13X775	DAIHATSU	7			
FB 10X690	HONDA	9	FB 13X775	FIAT	7			
FB 10X690	LANCIA	11	FB 13X775	HYUNDAI	9			
FB 10X690	PEUGEOT	19	FB 13X775	KIA	11			
FB 10X690	RENAULT	20, 21	FB 13X775	MAZDA	12			
FB 10X690	SEAT	22	FB 13X775	MERCEDES-BENZ	15			
FB 10X690	SUBARU	23	FB 13X775	NISSAN	17			
FB 10X715	AUDI	3	FB 13X775	PEUGEOT	19			
FB 10X715	CITROËN	6	FB 13X775	SEAT	22			
FB 10X715	FIAT	7	FB 13X775	TALBOT	23			
FB 10X715	LANCIA	11	FB 13X915	AUDI	3, 4			
FB 10X715	LAND ROVER	12	FB 13X915	FIAT	7			
FB 10X715	PEUGEOT	18, 19, 20	FB 13X915	FORD	9			
FB 10X715	ROVER	21	FB 13X915	OPEL	17, 18			
FB 10X715	SUBARU	23	FB 13X915	RENAULT	21			
FB 10X965	BMW	4, 5	FB 13X915	VOLVO	24, 25			
FB 10X965	HONDA	9	FB 3PK630	NISSAN	17			
FB 10X965	PORSCHE	20	FB 3PK630	TOYOTA	23, 24			
FB 10X965	VOLVO	24	FB 3PK798	HONDA	9			
FB 10X965	VW	25, 26	FB 3PK798	MAZDA	12			
FB 11.2X866	AUDI	3, 4	FB 3PK798	NISSAN	17			
FB 11.2X866	VW	25, 26	FB 4PK611	HYUNDAI	9, 10			
FB 11.5X755	FORD	9	FB 4PK910	CHEVROLET	5			



/ Liste des Composantes

		123 KIT				DAYCO		GATES
529 0150 10	533 0129 10	1	39					
	FB 3PK798	1						
	FB 6PK962	1						
529 0195 10	532 0639 10	1	39					
	532 0642 10	1						
	534 0550 10	1						
	535 0248 10	1						
	FB 5PK1815	1						
529 0203 10	534 0033 10	1	39					
	FB 6PK1903	1						
529 0204 10	532 0751 10	1	39					
	532 0752 10	1						
	534 0496 10	1						
	535 0275 10	1						
	FB 7PK1855	1						
529 0223 10	532 0295 10	1	39					K025PK1570
	534 0119 20	1						
	FB 5PK1570	1						
529 0274 10	532 0780 10	1	39					
	FB 7PK1165	1						
529 0275 10	534 0585 10	1	39					
	535 0247 10	1						
	FB 6PK2000	1						
529 0277 10	531 0760 10	1	39					K016DPK1838
	534 0047 10	1						
	535 0072 10	1						
	FB 6DPK1841	1						
529 0278 10	534 0629 10	1	39					
	535 0053 10	1						
	FB 7PK1642	1						
529 0280 10	531 0854 10	1	39			KPV191		K014PK1540
	532 0260 10	1						
	FB 4PK1538	1						
529 0281 10	532 0545 10	1	40					K016PK1973
	534 0130 20	1						
	FB 6PK1973	1						
529 0283 10	534 0027 10	1	40			KPV200		K017PK1135
	FB 7PK1135	1						

0...			1...		
0009932095	MERCEDES-BENZ	<b>FB 13X1350</b>	11750MA71C	NISSAN	<b>534 0629 10</b>
0009936796	MERCEDES-BENZ	<b>FB 7PK2418</b>	11750V2000	NISSAN	<b>FB 13X1100</b>
0009979292	MERCEDES-BENZ	<b>FB 13X1350</b>	11750Y9600	NISSAN	<b>FB 13X1100</b>
0019970092	MERCEDES-BENZ	<b>FB 13X1375</b>	119203HDOA	NISSAN	<b>FB 3PK798</b>
0019976492	MERCEDES-BENZ	<b>FB 13X750</b>	119209F615	NISSAN	<b>FB 6PK1093</b>
0019977192	MERCEDES-BENZ	<b>FB 13X1375</b>	119271HCOA	NISSAN	<b>529 0274 10</b>
0029974892	MERCEDES-BENZ	<b>FB 13X775</b>	11927ED000	NISSAN	<b>529 0274 10</b>
0029979992	MERCEDES-BENZ	<b>FB 13X1375</b>	11927ED00B	NISSAN	<b>529 0274 10</b>
0049974092	MERCEDES-BENZ	<b>FB 13X1375</b>	1195054A00	NISSAN	<b>FB 13X675</b>
0069970992	MERCEDES-BENZ	<b>FB 13X750</b>	1195054A10	NISSAN	<b>FB 13X675</b>
0099976392	MERCEDES-BENZ	<b>FB 13X1375</b>	11950D2010	NISSAN	<b>FB 13X750</b>
0139977492	MERCEDES-BENZ	<b>FB 7PK2418</b>	11950D2017	NISSAN	<b>FB 13X750</b>
0159970592	MERCEDES-BENZ	<b>FB 13X1075</b>	1204187	OPEL	<b>534 0610 10</b>
022145933H	VW	<b>FB 6PK1264</b>	1204187	VAUXHALL	<b>534 0610 10</b>
034260849	AUDI	<b>FB 13X915</b>	12311254885	BMW	<b>FB 10X965</b>
034260849A	AUDI	<b>FB 13X915</b>	12311288475	BMW	<b>FB 10X965</b>
035145271J	AUDI	<b>FB 10X965</b>	1271829	VOLVO	<b>FB 6PK1755</b>
035260849C	AUDI	<b>FB 10X965</b>	1340681	OPEL	<b>FB 13X915</b>
037145271F	SEAT	<b>FB 11.5X755</b>	1340A088	MITSUBISHI	<b>FB 3EPK863</b>
037145271F	VW	<b>FB 11.5X755</b>	1448817	FORD	<b>FB 13X1100</b>
03L903137J	AUDI	<b>FB 6PK1264</b>	1607581880	CITROËN	<b>FB 3EPK863</b>
0515V3	CITROËN	<b>544 0112 10</b>	1607581880	PEUGEOT	<b>FB 3EPK863</b>
0515V3	PEUGEOT	<b>544 0112 10</b>	1608673	FORD	<b>FB 13X1225</b>
054903137	AUDI	<b>FB 11.2X866</b>	1629874	FORD	<b>FB 13X915</b>
066145933K	VW	<b>FB 6PK1264</b>	1643815	FORD	<b>FB 13X915</b>
068260849E	VW	<b>FB 13X1225</b>	1648398	FORD	<b>FB 13X915</b>
068903137AE	VW	<b>FB 13X1225</b>	1C1Q6C301CB	FORD	<b>FB 6PK1955</b>
068903137AP	AUDI	<b>FB 10X715</b>	1E0715909	MAZDA	<b>FB 5PK675</b>
068903137AQ	AUDI	<b>FB 10X690</b>			
068903137D	VW	<b>FB 10X965</b>			
070903137A	AUDI	<b>FB 10X690</b>			
OK01232611	KIA	<b>FB 13X775</b>			
1...			2...		
1005135	FORD	<b>FB 5PK675</b>	23752AA150	SUBARU	<b>535 0316 10</b>
1017593	FORD	<b>FB 5PK675</b>	25183058	CHEVROLET	<b>FB 4PK910</b>
1033500	FORD	<b>FB 6PK1755</b>	25185133	CHEVROLET	<b>FB 5PK1570</b>
11287589365	BMW	<b>FB 8PK1478</b>	2521542040	HYUNDAI	<b>FB 13X750</b>
11287619248	BMW	<b>534 0627 10</b>	2521542041	HYUNDAI	<b>FB 13X750</b>
11287628659	BMW	<b>FB 8PK1478</b>	2722020000	MERCEDES-BENZ	<b>532 0866 10</b>
11287649371	BMW	<b>FB 8PK1478</b>	2722020819	MERCEDES-BENZ	<b>532 0866 10</b>
11287787535	BMW	<b>532 0804 10</b>	2722021019	MERCEDES-BENZ	<b>532 0866 10</b>
1129745	FORD	<b>FB 6PK2090</b>	2722021219	MERCEDES-BENZ	<b>532 0866 10</b>
11511706710	BMW	<b>FB 6PK2090</b>	2741533100	TOYOTA	<b>535 0303 10</b>
11511711091	BMW	<b>FB 6PK1955</b>	2761500060	MERCEDES-BENZ	<b>535 0328 10</b>
1172005E60	NISSAN	<b>FB 10X965</b>	2819932096	SMART	<b>FB 7PK1240</b>
1172005E70	NISSAN	<b>FB 10X965</b>			
1172005E70	NISSAN	<b>FB 13X775</b>			
117200777R	RENAULT	<b>FB 13X775</b>			
117201HC1A	NISSAN	<b>529 0280 10</b>			
117201HC1A	NISSAN	<b>529 0274 10</b>			
1172022J00	NISSAN	<b>FB 7PK1165</b>			
1172022J10	NISSAN	<b>FB 13X1075</b>			
117203VU0A	NISSAN	<b>FB 13X1075</b>			
117205453R	RENAULT	<b>FB 7PK1165</b>			
1172077A00	NISSAN	<b>FB 7PK1240</b>			
1172077A10	NISSAN	<b>FB 4PK910</b>			
117209C601	NISSAN	<b>FB 4PK910</b>			
117209C604	NISSAN	<b>FB 13X1100</b>			
117209C605	NISSAN	<b>FB 13X1100</b>			
11720BC20A	NISSAN	<b>FB 13X1100</b>			
11720P8010	NISSAN	<b>FB 7PK1135</b>			
11720VB500	NISSAN	<b>FB 13X1100</b>			
11720VB510	NISSAN	<b>FB 13X1075</b>			
1175001B00	NISSAN	<b>FB 13X1075</b>			
11750C6000	NISSAN	<b>FB 3PK630</b>			
11750D1100	NISSAN	<b>FB 13X1350</b>			
11750G9600	NISSAN	<b>FB 13X750</b>			
11750MA70A	NISSAN	<b>FB 13X1100</b>			
11750MA70B	NISSAN	<b>534 0629 10</b>			
11750MA71A	NISSAN	<b>534 0629 10</b>			
11750MA71B	NISSAN	<b>534 0629 10</b>			
			3...		
			31110671003	HONDA	<b>FB 10X965</b>
			31110P7A003	HONDA	<b>FB 3PK798</b>
			31110P7A013	HONDA	<b>FB 3PK798</b>
			31110PA6661	HONDA	<b>FB 10X965</b>
			31110PA6662	HONDA	<b>FB 10X965</b>
			31110PH3003	HONDA	<b>FB 3PK798</b>
			31110PH3003EH	HONDA	<b>FB 3PK798</b>
			31110PH3004	HONDA	<b>FB 3PK798</b>
			31110PH3004EH	HONDA	<b>FB 3PK798</b>
			31110PH3005	HONDA	<b>FB 3PK798</b>
			31110PH3J01	HONDA	<b>FB 3PK798</b>
			31110PH3J02	HONDA	<b>FB 3PK798</b>
			31110PH3J03	HONDA	<b>FB 3PK798</b>
			31170RZ0G01	HONDA	<b>534 0586 10</b>
			3599764	FORD	<b>FB 13X1100</b>
			3872248	FORD	<b>FB 13X1100</b>
			38920PH3003	HONDA	<b>FB 4PK910</b>
			38920PH4506	HONDA	<b>FB 4PK910</b>
			38920PH59520	HONDA	<b>FB 4PK910</b>
			38920PH59521	HONDA	<b>FB 4PK910</b>
			3904815	SEAT	<b>FB 13X775</b>
			4...		
			4565286	FORD	<b>FB 13X1100</b>
			46550322	FIAT	<b>FB 5PK1585</b>
			46550322	LANCIA	<b>FB 5PK1585</b>



<b>4...</b>			<b>7...</b>		
4827114	IVECO	<b>FB 13X750</b>	7302819	LANCIA	<b>FB 10X715</b>
4982547	FORD	<b>FB 13X1100</b>	73036GA150	SUBARU	<b>FB 13X1100</b>
<b>5...</b>			7310608	FORD	<b>FB 6PK1755</b>
5013540	FORD	<b>FB 13X1225</b>	74TF8620EA	FORD	<b>FB 13X1225</b>
5025006	FORD	<b>FB 13X915</b>	7553716	LANCIA	<b>FB 10X690</b>
5027577	FORD	<b>FB 13X1225</b>	7619248	BMW	<b>534 0627 10</b>
51758385	FIAT	<b>534 0610 10</b>	7628659	BMW	<b>FB 8PK1478</b>
51773551	FIAT	<b>534 0610 10</b>	7629235	LANCIA	<b>FB 13X750</b>
55184980	FIAT	<b>534 0610 10</b>	7651549	FIAT	<b>FB 13X750</b>
55190813	FIAT	<b>534 0610 10</b>	7655544	FIAT	<b>FB 13X750</b>
55190813	OPEL	<b>534 0610 10</b>	7655544	LANCIA	<b>FB 13X750</b>
55190813	SAAB	<b>534 0610 10</b>	7689128	FIAT	<b>FB 13X775</b>
55190813	VAUXHALL	<b>534 0610 10</b>	7700271121	RENAULT	<b>FB 10X690</b>
55560051	OPEL	<b>FB 5PK1570</b>	7700742336	RENAULT	<b>FB 10X690</b>
55560052	OPEL	<b>FB 5PK1570</b>	7701068435	RENAULT	<b>FB 10X690</b>
56992671000	HONDA	<b>FB 10X690</b>	7701477520	RENAULT	<b>529 0283 10</b>
56992689003	HONDA	<b>FB 10X690</b>	7701477533	DACIA	<b>529 0280 10</b>
56992689004	HONDA	<b>FB 10X690</b>	7701477533	RENAULT	<b>529 0280 10</b>
5717033910	HYUNDAI	<b>FB 13X675</b>	7723828	LANCIA	<b>FB 10X690</b>
5723102000	HYUNDAI	<b>FB 13X775</b>	7743134	LANCIA	<b>FB 10X690</b>
5723102010	HYUNDAI	<b>FB 13X775</b>	7771530	LANCIA	<b>FB 10X690</b>
5723122000	HYUNDAI	<b>FB 4PK611</b>	<b>8...</b>		
5723128400	HYUNDAI	<b>FB 13X675</b>	809110330	SUBARU	<b>FB 10X715</b>
5723128410	HYUNDAI	<b>FB 13X675</b>	8200421400	RENAULT	<b>FB 7PK1135</b>
5723129050	HYUNDAI	<b>FB 4PK611</b>	8200833551	RENAULT	<b>FB 7PK1135</b>
5723129100	HYUNDAI	<b>FB 13X675</b>	82401268	LANCIA	<b>FB 13X1400</b>
5723129200	HYUNDAI	<b>FB 13X675</b>	82401269	LANCIA	<b>FB 13X1225</b>
575073	CITROËN	<b>FB 10X715</b>	82MF8A615AA	FORD	<b>FB 13X1225</b>
575073	PEUGEOT	<b>FB 10X715</b>	83TF6C301CA	FORD	<b>FB 13X1225</b>
575078	PEUGEOT	<b>FB 4PK1230</b>	89BF6C301A1A	FORD	<b>FB 11.9X793</b>
5750A0	PEUGEOT	<b>FB 6PK1093</b>	<b>9...</b>		
5750C5	PEUGEOT	<b>FB 5PK768</b>	90019201350	PORSCHE	<b>FB 13X1100</b>
5750F6	CITROËN	<b>FB 10X715</b>	90019202750	PORSCHE	<b>FB 13X1100</b>
5750J4	CITROËN	<b>FB 6PK1093</b>	9091602044	TOYOTA	<b>FB 13X1075</b>
5750ST	CITROËN	<b>FB 10X715</b>	9091602045	TOYOTA	<b>FB 13X1075</b>
5750ST	PEUGEOT	<b>FB 10X715</b>	9091602078	TOYOTA	<b>FB 13X1225</b>
5750TF	CITROËN	<b>FB 6PK1093</b>	9091602491	TOYOTA	<b>FB 7PK1593</b>
5750TF	PEUGEOT	<b>FB 6PK1093</b>	9091602494	TOYOTA	<b>FB 7PK1593</b>
5750TR	CITROËN	<b>FB 5PK768</b>	9091602523	TOYOTA	<b>FB 7PK1093</b>
5750TR	PEUGEOT	<b>FB 5PK768</b>	9091602596	TOYOTA	<b>FB 7PK1593</b>
575108	CITROËN	<b>532 0424 10</b>	9091602597	TOYOTA	<b>FB 7PK1593</b>
575108	PEUGEOT	<b>532 0424 10</b>	9091612005	TOYOTA	<b>FB 7PK1093</b>
575114	CITROËN	<b>532 0424 10</b>	91153769	OPEL	<b>FB 8PK2188</b>
575114	PEUGEOT	<b>532 0424 10</b>	91541178	CITROËN	<b>FB 4PK1230</b>
5997007	LANCIA	<b>FB 10X690</b>	91541178	LADA	<b>FB 4PK1230</b>
<b>6...</b>			91829229	VOLVO	<b>FB 6PK1755</b>
6000625263	FIAT	<b>534 0610 10</b>	93181703	OPEL	<b>FB 13X915</b>
60513081	ALFA ROMEO	<b>FB 5PK675</b>	93185050	SAAB	<b>FB 6PK2345</b>
60534452	ALFA ROMEO	<b>FB 13X1100</b>	949602	OPEL	<b>FB 8PK2188</b>
60558595	ALFA ROMEO	<b>FB 5PK675</b>	95511411	OPEL	<b>534 0610 10</b>
60743778	ALFA ROMEO	<b>FB 13X1100</b>	95511411	VAUXHALL	<b>534 0610 10</b>
6109565	FORD	<b>FB 13X1225</b>	958506	VOLVO	<b>FB 13X1400</b>
6110301703	MERCEDES-BENZ	<b>544 0111 10</b>	95WF6C301BA	FORD	<b>FB 6PK1755</b>
6134738	FORD	<b>FB 11.9X793</b>	95WF6C301GA	FORD	<b>FB 6PK1755</b>
6174797	FORD	<b>FB 11.9X793</b>	960285	VOLVO	<b>FB 10X965</b>
6196578	FORD	<b>FB 11.9X793</b>	96146660	CITROËN	<b>532 0424 10</b>
6340557	OPEL	<b>534 0610 10</b>	96146660	PEUGEOT	<b>532 0424 10</b>
6340557	VAUXHALL	<b>534 0610 10</b>	96173680	CITROËN	<b>FB 5PK768</b>
645592	PEUGEOT	<b>FB 13X1350</b>	96239401	CHEVROLET	<b>FB 4PK910</b>
645627	PEUGEOT	<b>FB 13X1350</b>	96476110	CHEVROLET	<b>FB 5PK1570</b>
645641	PEUGEOT	<b>FB 13X1375</b>	966911	VOLVO	<b>FB 10X965</b>
645725	PEUGEOT	<b>FB 13X1350</b>	967113	VOLVO	<b>FB 13X1075</b>
<b>7...</b>			967137	VOLVO	<b>FB 13X1400</b>
71739605	LANCIA	<b>FB 13X750</b>	96FF6C301CC	FORD	<b>FB 5PK675</b>
71743966	FIAT	<b>534 0610 10</b>	96FF6C301CD	FORD	<b>FB 5PK675</b>
71753678	FIAT	<b>FB 5PK1585</b>	97074109	OPEL	<b>FB 13X915</b>
71753678	LANCIA	<b>FB 5PK1585</b>	973490	VOLVO	<b>FB 13X1075</b>
			977221	VOLVO	<b>FB 13X1350</b>
			977321	VOLVO	<b>FB 13X1350</b>



<b>9...</b>			<b>V...</b>		
977573	VOLVO	<b>FB 13X1400</b>	V86BB8A615AA	FORD	<b>FB 13X915</b>
978504	VOLVO	<b>FB 10X965</b>	<b>X...</b>		
9810856580	CITROËN	<b>535 0308 10</b>	XM348620AA	FORD	<b>FB 13X1100</b>
9810856580	PEUGEOT	<b>535 0308 10</b>	XM348620BA	FORD	<b>FB 13X1100</b>
9933201360	TOYOTA	<b>FB 13X1375</b>			
9933201395	TOYOTA	<b>FB 13X1400</b>			
9933210761	DAIHATSU	<b>FB 13X775</b>			
9934311060	TOYOTA	<b>FB 13X1075</b>			
9934311070	TOYOTA	<b>FB 13X1075</b>			
9936310630	TOYOTA	<b>FB 3PK630</b>			
9936320630	TOYOTA	<b>FB 3PK630</b>			
9936350630	TOYOTA	<b>FB 3PK630</b>			
9936380630	TOYOTA	<b>FB 3PK630</b>			
9936390630	TOYOTA	<b>FB 3PK630</b>			
9952211232	TOYOTA	<b>FB 13X1225</b>			
99919214650	PORSCHE	<b>FB 13X1075</b>			
99919217650	AUDI	<b>FB 10X715</b>			
99919233550	PORSCHE	<b>FB 13X1075</b>			
99919235250	PORSCHE	<b>FB 13X1075</b>			
99919236350	PORSCHE	<b>FB 13X1075</b>			
<b>A...</b>					
A0029974892	MERCEDES-BENZ	<b>FB 13X775</b>			
A195054A00	NISSAN	<b>FB 13X675</b>			
<b>C...</b>					
C20887	JAGUAR	<b>FB 13X750</b>			
<b>E...</b>					
ERC5146	LAND ROVER	<b>FB 13X750</b>			
ERR3287	LAND ROVER	<b>FB 7PK1593</b>			
<b>F...</b>					
F85118381A	MAZDA	<b>FB 13X775</b>			
<b>G...</b>					
GFB80910	ROVER	<b>FB 4PK910</b>			
GMB40910	ROVER	<b>FB 4PK910</b>			
<b>L...</b>					
LR028879	LAND ROVER	<b>532 0824 10</b>			
<b>M...</b>					
MB166411	MITSUBISHI	<b>FB 13X750</b>			
MB192977	MITSUBISHI	<b>FB 13X675</b>			
MB501594	MITSUBISHI	<b>FB 13X675</b>			
MB553392	MITSUBISHI	<b>FB 13X675</b>			
MD178431	MITSUBISHI	<b>FB 13X675</b>			
MD180581	MITSUBISHI	<b>FB 13X750</b>			
MD366490	MITSUBISHI	<b>FB 7PK2418</b>			
MD368210	MITSUBISHI	<b>532 0840 10</b>			
MN155725	MITSUBISHI	<b>FB 7PK2418</b>			
MN183597	MITSUBISHI	<b>FB 7PK2418</b>			
<b>P...</b>					
PE0115908	MAZDA	<b>FB 3PK798</b>			
PEDD15908	MAZDA	<b>FB 3PK798</b>			
<b>R...</b>					
RFG113813	MAZDA	<b>FB 5PK675</b>			
RFG113813A	MAZDA	<b>FB 5PK675</b>			
<b>S...</b>					
SU001A6341	TOYOTA	<b>535 0308 10</b>			
SU001A7070	TOYOTA	<b>535 0308 10</b>			



## Cross references / Correspondance des références

CONTITECH		CONTITECH		CONTITECH	
112X866LD		FB 11.2X866			
115X755LD		FB 11.5X755			
119X793LD		FB 11.9X793			
AVX10X690		FB 10X690			
AVX10X715		FB 10X715			
AVX10X965		FB 10X965			
AVX13X1075		FB 13X1075			
AVX13X1100		FB 13X1100			
AVX13X1225		FB 13X1225			
AVX13X1350		FB 13X1350			
AVX13X1375		FB 13X1375			
AVX13X1400		FB 13X1400			
AVX13X675		FB 13X675			
AVX13X750		FB 13X750			
AVX13X775		FB 13X775			
AVX13X915		FB 13X915			
3PK630		FB 3PK630			
3PK798		FB 3PK798			
4PK611		FB 4PK611			
4PK910		FB 4PK910			
5PK675		FB 5PK675			
5PK768		FB 5PK768			
4PK1230		FB 4PK1230			
5PK1570		FB 5PK1570			
5PK1585		FB 5PK1585			
6PK1095		FB 6PK1093			
6PK1264		FB 6PK1264			
6PK1755		FB 6PK1755			
6PK1955		FB 6PK1955			
6PK2090		FB 6PK2090			
6PK2345		FB 6PK2345			
7PK1093		FB 7PK1093			
7PK1165		FB 7PK1165			
7PK1240		FB 7PK1240			
7PK1593		FB 7PK1593			
7PK2418		FB 7PK2418			
8PK1478		FB 8PK1478			
8PK2188		FB 8PK2188			
3PK863ELAST		FB 3EPK863			
V85540		532 0866 10			
VD1036		544 0111 10			







## Cross references / Correspondance des références

DAYCO		DAYCO		DAYCO	
10A0690C	FB 10X690				
10A0710C	FB 10X715				
10A0750C	FB 11.5X755				
10A0960C	FB 10X965				
11A0865C	FB 11.2X866				
13A0675C	FB 13X675				
13A0750C	FB 13X750				
13A0925C	FB 13X915				
13A1075HD	FB 13X1075				
13A1100C	FB 13X1100				
13A1225C	FB 13X1225				
13A1350C	FB 13X1350				
13A1350HD	FB 13X1350				
13A1375C	FB 13X1375				
13A1375HD	FB 13X1375				
13A1400HD	FB 13X1400				
APV1088	534 0610 10				
APV2134	532 0866 10				
APV2211	532 0424 10				
APV2986	532 0840 10				
APV3239	534 0627 10				
DPV1052	544 0112 10				
DPV1126	544 0111 10				
KPV191	529 0280 10				
KPV200	529 0283 10				
3PK630	FB 3PK630				
3PK800	FB 3PK798				
4PK610	FB 4PK611				
4PK910	FB 4PK910				
5PK673	FB 5PK675				
5PK768	FB 5PK768				
4PK1225	FB 4PK1230				
5PK1572	FB 5PK1570				
5PK1585	FB 5PK1585				
6PK1095	FB 6PK1093				
6PK1264	FB 6PK1264				
6PK1755	FB 6PK1755				
6PK1955	FB 6PK1955				
6PK2090	FB 6PK2090				
6PK2345	FB 6PK2345				
7PK1095	FB 7PK1093				
7PK1132	FB 7PK1135				
7PK1240	FB 7PK1240				
7PK1595	FB 7PK1593				
7PK2418	FB 7PK2418				
8PK2190	FB 8PK2188				





# Cross references / Correspondance des références

GATES		GATES		GATES	
6261MC	FB 10X715				
6266MC	FB 10X965				
6280MC	FB 10X690				
6312MC	FB 11.9X793				
6389MC	FB 11.5X755				
6391MC	FB 11.2X866				
6460MC	FB 13X750				
6461EXL	FB 13X775				
6467MC	FB 13X915				
6473EXL	FB 13X1075				
6474EXL	FB 13X1100				
6479MC	FB 13X1225				
6484EXL	FB 13X1350				
6485MC	FB 13X1375				
6486EXL	FB 13X1400				
6607ES	FB 13X675				
3PK628	FB 3PK630				
3PK800	FB 3PK798				
4PK613	FB 4PK611				
4PK913	FB 4PK910				
5PK675	FB 5PK675				
5PK768	FB 5PK768				
4PK1230	FB 4PK1230				
5PK1570	FB 5PK1570				
5PK1590	FB 5PK1585				
6PK1093	FB 6PK1093				
6PK1263	FB 6PK1264				
6PK1955	FB 6PK1955				
6PK2090	FB 6PK2090				
6PK2345	FB 6PK2345				
7PK1095	FB 7PK1093				
7PK1135	FB 7PK1135				
7PK1165	FB 7PK1165				
7PK1240	FB 7PK1240				
7PK1593	FB 7PK1593				
7PK2418	FB 7PK2418				
8PK1475	FB 8PK1478				
8PK2188	FB 8PK2188				
3PK842SF	FB 3EPK863				
6PK1755XS	FB 6PK1755				
K014PK1540	529 0280 10				
K016PK1973	529 0281 10				
K017PK1135	529 0283 10				
K025PK1570	529 0223 10				
K016DPK1838	529 0277 10				
T36019	532 0424 10				
T36749	532 0840 10				
T38099	532 0866 10				
T39017	534 0610 10				







### Cross references / Correspondance des références

Schaeffler Auto- motive Aftermar- ket		Schaeffler Auto- motive Aftermar- ket		Schaeffler Auto- motive Aftermar- ket	
F-121194.04	532 0424 10				
F-121373.1	532 0424 10				
F-576851.01	532 0804 10				
F-577850.05	534 0629 10				
F-577982	532 0824 10				
F-581210	535 0328 10				
F-581210.01	535 0328 10				
F-581210.02	535 0328 10				
F-600037	535 0315 10				
F-602157	535 0298 10				
F-615104	534 0586 10				
F-619416	532 0824 10				
F-620939	532 0804 10				
F-621236.01	535 0303 10				





# Cross references / Correspondance des références

RUVILLE 	RUVILLE 	RUVILLE 
515102	544 0111 10	
515917	544 0112 10	
5532888	529 0203 10	
55927	532 0424 10	
55986	535 0308 10	
56020	534 0610 10	
56847	535 0298 10	
56849	534 0629 10	
56850	535 0315 10	
56954	535 0303 10	
5708680	529 0150 10	
57110	532 0824 10	
57363	532 0840 10	
57445	534 0586 10	
57511	532 0866 10	
5761080	529 0204 10	
57615	532 0804 10	
57622	534 0627 10	
58117	535 0316 10	
8PK1478	FB 8PK1478	







## Cross references / Correspondance des références

SKF		SKF		SKF	
VKMV3PK630	<b>FB 3PK630</b>				
VKMV4PK613	<b>FB 4PK611</b>				
VKMV4PK908	<b>FB 4PK910</b>				
VKMV4PK910	<b>FB 4PK910</b>				
VKMV5PK672	<b>FB 5PK675</b>				
VKMV5PK770	<b>FB 5PK768</b>				
VKMV4PK1230	<b>FB 4PK1230</b>				
VKMV5PK1568	<b>FB 5PK1570</b>				
VKMV5PK1570	<b>FB 5PK1570</b>				
VKMV5PK1585	<b>FB 5PK1585</b>				
VKMV6PK1261	<b>FB 6PK1264</b>				
VKMV6PK1264	<b>FB 6PK1264</b>				
VKMV6PK1755	<b>FB 6PK1755</b>				
VKMV6PK1954	<b>FB 6PK1955</b>				
VKMV6PK2090	<b>FB 6PK2090</b>				
VKMV7PK1093	<b>FB 7PK1093</b>				
VKMV7PK1135	<b>FB 7PK1135</b>				
VKMV7PK1165	<b>FB 7PK1165</b>				
VKMV7PK1240	<b>FB 7PK1240</b>				
VKMV7PK1595	<b>FB 7PK1593</b>				
VKMV7PK2415	<b>FB 7PK2418</b>				
VKMV7PK2420	<b>FB 7PK2418</b>				
VKMV8PK1478	<b>FB 8PK1478</b>				
VKM32046	<b>534 0610 10</b>				
VKM33006	<b>532 0424 10</b>				
VKM37023	<b>532 0824 10</b>				
VKM38062	<b>532 0866 10</b>				
VKM65044	<b>532 0840 10</b>				
VKMA36220	<b>529 0277 10</b>				
VKMA62133	<b>529 0274 10</b>				
VKMV10AVX690	<b>FB 10X690</b>				
VKMV10AVX710	<b>FB 10X715</b>				
VKMV10AVX965	<b>FB 10X965</b>				
VKMV119X793	<b>FB 11.9X793</b>				
VKMV13AVX1085	<b>FB 13X1075</b>				
VKMV13AVX1100	<b>FB 13X1100</b>				
VKMV13AVX1225	<b>FB 13X1225</b>				
VKMV13AVX1375	<b>FB 13X1375</b>				
VKMV13AVX1400	<b>FB 13X1400</b>				
VKMV13AVX655	<b>FB 13X675</b>				
VKMV13AVX750	<b>FB 13X750</b>				
VKMV13AVX915	<b>FB 13X915</b>				



# Cross references / Correspondance des références

SNR 	SNR 	SNR 
GA35138 GA35800 GA35963 CA7PK1132	532 0866 10 534 0610 10 532 0424 10 FB 7PK1135	





529 0150 10



529 0195 10



529 0203 10



529 0204 10



529 0223 10



529 0274 10



529 0275 10



529 0277 10



529 0278 10



529 0280 10



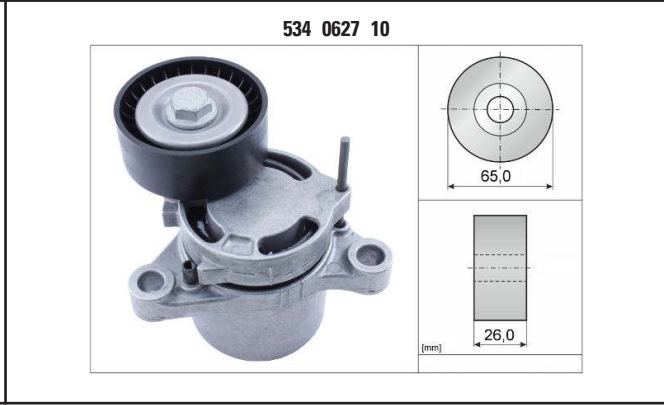
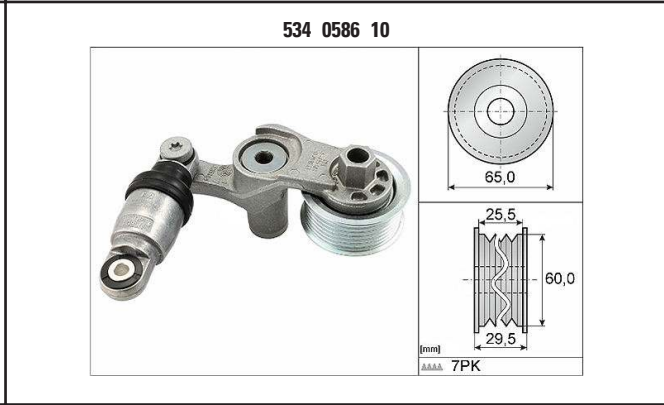
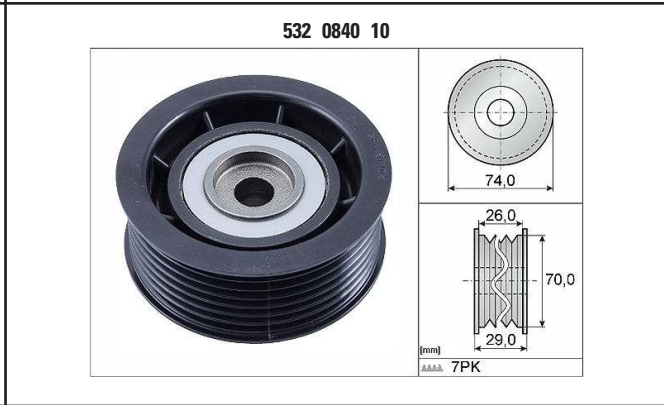

534 0629 10

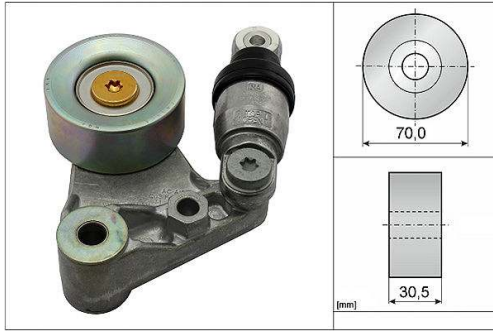

535 0298 10



535 0303 10



535 0308 10



535 0315 10



535 0316 10



535 0328 10



544 0111 10



544 0112 10



FB 10X690





<p>FB 10X715</p>	<p>FB 10X965</p>
<p>FB 11.2X866</p>	<p>FB 11.5X755</p>
<p>FB 11.9X793</p>	<p>FB 13X1075</p>
<p>FB 13X1100</p>	<p>FB 13X1225</p>
<p>FB 13X1350</p>	<p>FB 13X1375</p>











<p>FB 13X1400</p>	<p>FB 13X675</p>
<p>FB 13X750</p>	<p>FB 13X775</p>
<p>FB 13X915</p>	<p>FB 3EPK863</p>
<p>FB 3PK630</p>	<p>FB 3PK798</p>
<p>FB 4PK1230</p>	<p>FB 4PK611</p>







<p>FB 6PK2345</p> 	<p>FB 7PK1093</p> 
<p>FB 7PK1135</p> 	<p>FB 7PK1165</p> 
<p>FB 7PK1240</p> 	<p>FB 7PK1593</p> 
<p>FB 7PK2418</p> 	<p>FB 8PK1478</p> 
<p>FB 8PK2188</p> 