



Entraînement des accessoires

Octobre 2017

































Nouveautés VL-VUL



SCHAEFFLER
AUTOMOTIVE AFTERMARKET

Symboles & Abréviations

	Poulie roue libre, alternateur
	Courroie trapézoïdale à nervures
	Poulie renvoi/transmission, courroie trapézoïdale à nervures
	Poulie, vilebrequin
	Pompe à eau + Jeu de courroie trapézoïdale à nervures
	Tendeur, courroie trapézoïdale à nervures
	Poulie-tendeur, courroie trapézoïdale à nervures
	Jeu de courroies trapézoïdales à nervures
	France
	Japon
	Dynamo pour véhicules avec deux générateurs
	Compresseur de climatisation pour véhicules avec système de climatisation pour véhicules avec climatiseur automatique
	Pompe de la direction assistée pour véhicules avec direction assistée
	pour n° fabricant
	Année à partir de
	Année jusqu'à
	N° de châssis à partir de
	N° de châssis jusqu'à
	Version d'équipement
	N° de moteur de
	N° de moteur à
	Code moteur
	boîte de vitesses manuelle
	Boîte automatique entièrement automatique
	pas pour boîte de vitesse séquentielle
	pour numéro OE

LHD	pour véhicules avec direction à gauche
RHD	pour véhicules avec direction à droite
	pour véhicules sans direction assistée électrique
START/STOP	pour véhicules avec fonction Stop/Start
START/STOP	pour véhicules sans fonction Stop/Start
A/C	pour véhicules sans système de climatisation
	pour véhicules sans direction assistée
	pour véhicules sans réglage de niveau
	avec poulie débrayable
	avec poulie d'entraînement pour vilebrequin
OPTION	au choix
	pas pour version d'équipement
	pas pour modèle type
	Modèle type
(HY)	hydraulique
...A	Courant de charge de l'alternateur (A)
{ignore}	avec poulie d'entraînement pour vilebrequin
FAN	Ventilateurs
H ... mm	Hauteur [mm]
MY ...	
OE ...	pour numéro OE
optional	au choix
ORGA ...	N° d'organisation à partir de N° d'organisation jusqu'à
SUPERC	Compresseur à air
without catalyst	sans catalyseur
WP	Pompe à eau
x2	pour véhicules avec deux générateurs

ALFA ROMEO
145 / 146 (930_, 930_)

1.4 i.e. 16V T.S.; 1.6 i.e. 16V T.S.; 1.8 i.e. 16V T.S.	11.96-01.01	AR 32201; AR 33503; AR 38201; AR 38401; AR 38501; AR 67106; AR 67199; AR 67601; (76-106kW)			A/C, # OE 71739915	FB 6PK1845	41
---	-------------	--	--	--	--------------------	------------	----

147 (937_)

1.6 16V T.SPARK; 1.6 16V T.SPARK ECO	01.01-03.10	AR 32104; AR 37203; (77-88kW)			A/C, # 2835764→	FB 6PK1845	41
--------------------------------------	-------------	-------------------------------	--	--	-----------------	------------	----

155 (167_)

1.6 16V T.S.	05.96-12.97	AR 67601; (88kW)			A/C	FB 6PK1845	41
1.7 T.S. 16V	05.96-12.97	AR 67106; (103kW)			A/C	FB 6PK1845	41
2.5 TD	04.93-12.97	VM 07 B; VM 31 B; (92kW)				FB 7PK1715	42

156 (932_, 932_)

1.6 16V T.SPARK.; 1.6 16V T.SPARK; 1.8 16V T.SPARK; 1.9 JTD	09.97-05.06	AR 32102; AR 32103; AR 32104; AR 32201; AR 32205; AR 32302; AR 67601; (77-106kW)			A/C, # OE 60815887	FB 6PK1845	41
1.9 JTD	05.00-05.01	AR 32302; AR 37101; (77-81kW)			A/C, # OE 71739915	FB 6PK1845	41

164 (164_)

2.5 TD	09.92-09.98	VM 08 B; VM 32 B; (92kW)			A/C	FB 7PK1715	42
--------	-------------	--------------------------	--	--	-----	------------	----

GT (937_)

1.8 TS	11.03-09.10	AR 32205; (103kW)			A/C	FB 6PK1845	41
--------	-------------	-------------------	--	--	-----	------------	----

AUDI
100 (4A, C4, 4A, C4)

2.8 E; 2.8 E quattro	12.90-07.94	AAH; (128kW)			A/C, # →4A-N-023 926	FB 6PK2280	41
----------------------	-------------	--------------	--	--	----------------------	------------	----

A1 (8XA, 8XF, 8X1, 8XK)

1.4 TFSI	01.11-	CAVG; CTHG; CTJA; (136kW)			A/C	FB 6PK1700	41
----------	--------	---------------------------	--	--	-----	------------	----

A4 (8K2, B8, 8K5, B8)

2.0 TDI	11.07-12.15	CAGB; CJCB; CSUB; (100kW)			A/C, # CAGB, CJCB, A/C	529 0239 10	36
2.0 TDI	11.07-12.15	CAGA; CJCA; CMEA; CMFA; (105kW)			A/C, # CAGA, CMEA, A/C	529 0239 10	36
2.0 TDI; 2.0 TDI quattro	01.08-03.12	CAHA; (125kW)			A/C	529 0239 10	36
2.0 TDI	04.08-12.15	CAGB; CJCB; CSUB; (100kW)			A/C, # CAGB, A/C	529 0239 10	36
2.0 TDI	06.08-12.15	CAGC; CJCC; (88kW)			A/C, # CAGC, A/C	529 0239 10	36
2.0 TDI	08.08-12.15	CAHB; CGLD; CNHC; (120kW)			A/C, # CAHB, A/C	529 0239 10	36

A4 Allroad (8KH, B8)

2.0 TDI quattro	04.09-05.16	CAHA; (125kW)			A/C	529 0239 10	36
2.0 TDI quattro	04.09-05.16	CAHB; CGLD; CNHC; (120kW)			A/C, # CAHB, A/C	529 0239 10	36
2.0 TDI quattro	09.09-05.16	CAGB; CJCB; CSUB; (100kW)			A/C, # CAGB, A/C	529 0239 10	36

A4 (8ED, B7, 8EC, B7)

3.2 FSI; 3.2 FSI quattro	01.05-06.08	AUK; BKH; (188kW)			A/C	529 0242 10	36
3.2 FSI; 3.2 FSI quattro	01.05-06.08	AUK; (188kW)			A/C, # 8E-5-400 001→, A/C	529 0242 10	36

A4 Décapotable (8H7, B6, 8HE, B7)

3.2 FSI; 3.2 FSI quattro	01.06-03.09	AUK; (188kW)			A/C	529 0242 10	36
--------------------------	-------------	--------------	--	--	-----	-------------	----

A5 Décapotable (8F7)

2.0 TDI	05.09-03.12	CAHA; (125kW)			A/C	529 0239 10	36
---------	-------------	---------------	--	--	-----	-------------	----

A5 (8TA, 8T3)

2.0 TDI; 2.0 TDI quattro	08.08-03.12	CAHA; (125kW)			A/C	529 0239 10	36
2.0 TDI	09.09-01.17	CAGA; CJCA; CMEA; CMFA; (105kW)			A/C, # CAGA, CMEA, A/C	529 0239 10	36
2.0 TDI	09.09-01.17	CAGB; CJCB; CSUB; (100kW)			A/C, # CAGB, A/C	529 0239 10	36
2.0 TDI	09.09-01.17	CAHB; CGLD; CNHC; (120kW)			A/C, # CAHB, A/C	529 0239 10	36

A6 Allroad (4FH, C6)

3.2 FSI quattro	05.06-10.08	AUK; (188kW)			A/C	529 0242 10	36
-----------------	-------------	--------------	--	--	-----	-------------	----

A6 (4F5, C6, 4F2, C6)

2.0 TDI	07.04-08.11	BNA; BRF; CAGB; (100kW)			A/C, # CAGB, A/C	529 0239 10	36
2.0 TDI	10.08-08.11	CAHA; (125kW)			A/C	529 0239 10	36
2.4; 2.4 quattro; 2.8 FSI; 2.8 FSI quattro	05.04-08.11	BDW; BDV; CCDA; CCEA; (130-162kW)			A/C	529 0242 10	36
3.2 FSI; 3.2 FSI quattro	05.04-05.09	AUK; BKH; (188kW)			A/C, # 4F-5-000 001→, A/C	529 0242 10	36

A6 (4G5, C7, 4GD, 4G2, C7, 4GC)

2.8 FSI; 2.8 FSI quattro	11.10-04.15	CHVA; (150kW)				FB 6PK2285	42
RS6 performance quattro; RS6 quattro; S6 quattro	02.12-	CEUC; CRDB; CTGE; CWUB; CWUC; (309-445kW)				FB 5PK985	41

A7 Sportback (4GA, 4GF)

2.8 FSI; 2.8 FSI quattro	10.10-	CHVA; CNYA; (150kW)				FB 6PK2285	42
RS7 performance quattro; RS7 quattro; S7 quattro	02.12-	CEUC; CRDB; CTGE; CWUB; CWUC; (309-445kW)				FB 5PK985	41



AUDI

A8 (4H_)

4.0 TFSI quattro; S8 plus quattro; S8 quattro	03.12-	CEUA; CGTA; CTFA; CTGA; DDTA; (309-445kW)			FB 5PK985	41
---	--------	---	--	--	------------------	----

Q5 (8R)

2.0 TDI; 2.0 TDI quattro	11.08-	CAHA; CGLB; CJCA; CMGA; (105-125kW)		A/C	529 0239 10	36
2.0 TDI	11.10-	CJCB; CSUB; (100kW)		CJCB, A/C	529 0239 10	36
2.0 TDI quattro	11.08-	CAHB; CGLA; CGLD; CNHC; (120kW)		CAHB, A/C	529 0239 10	36
2.0 TDI quattro	08.09-	CAGB; CJCB; CSUB; (100kW)		CAGB, A/C →MY 2012, CJCB, A/C	529 0239 10	36
2.0 TDI quattro	08.09-	CAGA; CJCA; (105kW)		CAGA, A/C →MY 2012, CJCA, A/C	529 0239 10	36

Q7 (4L)

3.0 TDI quattro	03.06-05.10	BUG; BUN; CASB; (155-171kW)		4L-9-017 201→	FB 6PK2478	42
3.0 TDI quattro	11.07-08.15	CASA; CCMA; CJGA; CNRB; (176kW)		CASA, CASB, 4L-9-017 201→ CCMA,	FB 6PK2478	42
3.0 TDI quattro; 3.0 TFSI quattro	06.09-08.15	CATA; CJTB; CJTC; CJWB; CJWC; CJWE; CNA; CTWA; CTWB; (165-245kW)			FB 6PK2478	42

V8 (4A, 4C_)

3.6 quattro; 4.2 quattro	10.88-02.94	ABH; PT; (180-206kW)		4C-N-000 001→	FB 6PK2478	42
--------------------------	-------------	----------------------	--	---------------	-------------------	----

BENTLEY

CONTINENTAL Coupé (3W_) / CONTINENTAL Décapotable (3W_)

4.0 FLEX AWD	09.11-	CMMC; CMMD; CYCA; CYCB; DCCA; (373-426kW)			FB 5PK985	41
--------------	--------	---	--	--	------------------	----

BMW

1 (E87)

116 i	11.03-06.11	N43 B16 A; N45 B16 A; (85-90kW)		F-236566.XX, N45 B16 A, A/C	529 0254 10	37
				F-236528.XX, N45 B16 A, A/C	529 0255 10	37
118 i; 120 i	11.03-06.11	N43 B20 A; N46 B20 A; N46 B20 B; N46 B20 BD; N46 B20 C; N46 B20 CC; (95-115kW)		F-236566.XX, N46 B20 *, A/C	529 0254 10	37
				F-236528.XX, N46 B20 *, A/C	529 0255 10	37

1 (E82, E81, E88)

116 i	03.07-12.11	N43 B16 A; N43 B16 AA; N45 B16 A; (85-90kW)		F-236566.XX, N45 B16 A, A/C	529 0254 10	37
				F-236528.XX, N45 B16 A, A/C	529 0255 10	37
118 i	09.08-12.13	N46 B20 B; (100kW)		A/C	529 0255 10	37
120 i	09.06-10.11	N46 B20 B; N46 B20 C; (115kW)		F-236566.XX, N46 B20 *, A/C	529 0254 10	37
				F-236528.XX, N46 B20 *, A/C	529 0255 10	37
120 i	03.08-12.13	N46 B20 B; N46 B20 C; N46 B20 E; (115kW)		F-236566.XX, A/C	529 0254 10	37
				F-236528.XX, A/C	529 0255 10	37
135 i	10.07-12.13	N54 B30 A; N55 B30 A; (225kW)			FB 7PK1855	42

3 (E46, E46, E46, E46, E46)

316 Ci; 316 i; 316 ti; 318 Ci; 318 i; 318 ti	12.00-12.07	N40 B16 A; N42 B18 A; N42 B20 A; N45 B16 A; N46 B18 A; N46 B20 A; N46 B20 B; N46 B20 C; (85-110kW)		F-236566.XX, A/C	529 0254 10	37
				F-236528.XX, A/C	529 0255 10	37
318 Ci	03.05-07.06	N46 B20 A; (110kW)		A/C	529 0254 10	37

3 (E90, E91)

316 d	07.09-12.11	N47 D20 C; (85kW)		02.10→, A/C	529 0249 10	36
316 d; 320 d; 320 d xDrive	09.09-06.12	N47 D20 C; (85-135kW)		A/C	529 0249 10	36
316 i; 318 i; 320 i	06.04-06.12	N45 B16 A; N46 B20 A; N46 B20 B; N46 B20 C; (85-110kW)		F-236566.XX, A/C	529 0254 10	37
				F-236528.XX, A/C	529 0255 10	37
318 d; 320 d; 320 d xDrive	02.07-06.12	N47 D20 A; N47 D20 C; (100-130kW)		12.09→, A/C	529 0249 10	36
320 d	02.04-12.11	M47 D20 (204D4); N47 D20 C; (120kW)		09.09→, A/C	529 0249 10	36
320 d; 320 d xDrive	09.07-06.12	N47 D20 A; N47 D20 C; (120-135kW)		03.10→, A/C	529 0249 10	36
320 d xDrive; 320 xd	09.07-12.11	N47 D20 C; (120-130kW)		02.09→, A/C	529 0249 10	36
320 si	09.05-08.06	N45 B20 A; (127kW)		A/C	529 0255 10	37
335 i; 335 i xDrive; 335 xi	03.06-05.12	N54 B30 A; N55 B30 A; (225kW)			FB 7PK1855	42

BMW
3 Coupé (E92)

320 d; 320 d xDrive; 320 xd	09.06-02.10	N47 D20 A; N47 D20 C; (130kW)			N47N, Facelift/ LCI, A/C	529 0249 10	36
320 d	03.07-06.13	N47 D20 A; N47 D20 C; (120kW)			03.10→, A/C	529 0249 10	36
320 d; 320 d xDrive	03.10-06.13	N47 D20 C; (135kW)			A/C	529 0249 10	36
320 i	11.06-06.07	N46 B20 A; (110kW)			F-236566.XX, A/C	529 0254 10	37
					F-236528.XX, A/C	529 0255 10	37
335 i; 335 i xDrive; 335 xi	11.05-12.13	N54 B30 A; N55 B30 A; (225kW)				FB 7PK1855	42

3 Décapotable (E93)

320 d	09.07-02.10	N47 D20 A; N47 D20 C; (130kW)			N47N, Facelift/ LCI, A/C	529 0249 10	36
320 d	01.08-12.13	N47 D20 C; (120kW)			03.10→, A/C	529 0249 10	36
320 d	03.10-10.13	N47 D20 C; (135kW)			A/C	529 0249 10	36
320 i	01.07-08.13	N46 B20 A; (110kW)			A/C	529 0254 10	37
335 i	05.06-10.13	N54 B30 A; N54 B30 B; N55 B30 A; (225kW)				FB 7PK1855	42

5 (E60)

520 i	04.06-12.09	N46 B20 B; (115kW)			A/C	529 0254 10	37
-------	-------------	--------------------	--	--	-----	-------------	----

5 (E34, E34)

530 i V8; 540 i; 540 i V8	09.92-01.97	M60 B30 (308S1); M60 B40 (408S1); (160-210kW)				FB 7PK1605	42
---------------------------	-------------	---	--	--	--	------------	----

7 (E32)

730 i,iL V8; 740 i,iL V8	04.92-09.94	M60 B30 (308S1); M60 B40 (408S1); (160-210kW)			WP	FB 7PK1605	42
--------------------------	-------------	---	--	--	----	------------	----

7 (E38)

730 i, iL	10.94-11.01	M60 B30 (308S1); (155-160kW)			WP	FB 7PK1605	42
740 i, iL	10.94-11.01	M60 B40 (408S1); (210kW)				FB 7PK1605	42

8 (E31)

840 i	02.93-02.96	M60 B40 (408S1); (210kW)				FB 7PK1605	42
-------	-------------	--------------------------	--	--	--	------------	----

X1 (E84)

sDrive 18 i	01.10-06.15	N46 B20 B; (110kW)			F-236566.XX, A/C	529 0254 10	37
					F-236528.XX, A/C	529 0255 10	37
xDrive 25 d	10.09-06.15	N47 D20 D; (160kW)			A/C	529 0249 10	36

X3 (E83)

2.0 i; xDrive 20 i	07.05-08.11	N46 B20 B; (110kW)			A/C	529 0255 10	37
--------------------	-------------	--------------------	--	--	-----	-------------	----

Z4 Roadster (E85)

2.0 i	03.05-02.09	N46 B20 A; N46 B20 B; (110kW)			F-236566.XX, A/C	529 0254 10	37
					F-236528.XX, A/C	529 0255 10	37

CHEVROLET
ASTRO Autobus/Autocar / ASTRO Camionnette

4.3; 4.3 AWD; 4.3 Luxury; 4.3 Luxury AWD	10.84-09.95	LB4; (107-127kW)				FB 6PK2305	42
--	-------------	------------------	--	--	--	------------	----

CAPTIVA (C100, C140)

2.4	03.11-	A 24 XE; LE5; (123kW)				FB 6PK1980	41
-----	--------	-----------------------	--	--	--	------------	----

CHRYSLER
VOYAGER IV (RG, RS)

2.4	02.00-12.08	EDZ; (108kW)				FB 6PK1250	41
-----	-------------	--------------	--	--	--	------------	----

CITROËN
AX (ZA-)

14 D; 15 D	09.88-12.97	K9A (TUD3); K9Y (TUD3Y); VJY (TUD5); VJZ (TUD5); (37-43kW)			A/C,	529 0258 10	37
					A/C,	529 0259 10	37

BERLINGO (M_, MF, B9, B9)

1.2 PureTech 110	02.16-	(81kW)			EP2DT F-580958	535 0304 10	39
1.4 i	07.96-10.08	KFW (TU3JP); KFX (TU3JP); (55kW)				FB 5PK725	40
1.6 HDi 110; 1.6 HDi 110	08.05-12.11	9HZ (DV6TED4); (80kW)			→ORGA 10555	544 0079 20	39
1.6 HDi 90; 1.6 HDi 90; 1.6 HDi 90 16V	07.05-12.11	9HP (DV6ATED4); 9HS (DV6ATED4BU); 9HX (DV6ATED4); 9HX (DV6AUTED4); (66-68kW)			→ORGA 10562	544 0079 20	39
1.6 VTi 120; 1.6 VTi 95	11.09-	5FK (EP6CB); 5FS (EP6C); (72-88kW)			A/C	529 0266 10	38
1.9 D; 1.9 D 70; 1.9 D 70 4WD	07.98-12.11	WJY (DW8B); WJZ (DW8); (51kW)			A/C	544 0087 20	39

BX (XB-, XB-)

19 D	09.83-12.94	162 (XUD9); D9A (XUD9); D9B (XUD9A/U); DJZ (XUD9Y); (47-51kW)			A/C,	529 0256 10	37
19 GTi 16V	09.87-02.93	D6C (XU9J4); DFW (XU9J4); (108-116kW)				FB 5PK725	40



CITROËN

C1 (PM_, PN_)

1.4 HDi	06.05-09.14	8HT (DV4TD); (40kW)			544 0079 20	39
---------	-------------	---------------------	--	--	-------------	----

C1 II

1.0 VTi 68	04.14-	1KR-FE; (51kW)		 A/C	529 0262 10	37
				 A/C	529 0268 10	38



C2 (JM_)

1.4 HDi	09.03-	8HX (DV4TD); 8HZ (DV4TD); (50kW)		→ORGA 10415	544 0079 20	39
1.6 HDi	09.05-	9HZ (DV6TED4); (80kW)		→ORGA 10555	544 0079 20	39



C2 ENTERPRISE

1.4 HDi	04.09-	8HX (DV4TD); (50kW)		→ORGA 10415,  8HX	544 0079 20	39
---------	--------	---------------------	--	--	-------------	----

C3 (FC_)

1.4 16V HDi	02.02-	8HY (DV4TED4); (66kW)			544 0079 20	39
1.4 HDi; 1.4 HDi 70; 1.6 16V HDi	02.02-	8HR (DV4C); 8HX (DV4TD); 8HZ (DV4TD); 9HX (DV6ATED4); 9HZ (DV6TED4); (50-80kW)		→ORGA 10555	544 0079 20	39
1.4 LPG; 1.4 VTi; 1.4 VTi 95; 1.6 VTi 120	11.09-	5FS (EP6C); 8FN (EP3); 8FP (EP3); 8FR (EP3); (70-88kW)		 A/C	529 0266 10	38
1.6 HDi 90	11.09-	9HX (DV6ATED4); (66kW)		→ORGA 10562	544 0079 20	39



C3 Picasso

1.4 VTi 95; 1.4 VTi 95 LPG; 1.6 VTi 120; 1.6 VTRi	02.09-	5FP (EP6); 5FS (EP6C); 5FW (EP6); 8FN (EP3); 8FP (EP3); 8FS (EP3); (70-88kW)		 A/C	529 0266 10	38
1.6 HDi	02.09-	9HX (DV6ATED4); 9HZ (DV6TED4); (66-80kW)			544 0079 20	39



C3 Pluriel (HB_)

1.4 HDi	04.04-	8HX (DV4TD); (50kW)			544 0079 20	39
---------	--------	---------------------	--	--	-------------	----

C4 I (LC_, LA_)

1.6 HDi	11.04-07.11	9HX (DV6ATED4); 9HY (DV6TED4); 9HZ (DV6TED4); (66-80kW)		→ORGA 10555	544 0079 20	39
1.6 THP 140; 1.6 THP 150; 1.6 VTi 120	07.08-07.11	5FT (EP6DT); 5FW (EP6); 5FX (EP6DT); (88-110kW)		 A/C	529 0266 10	38



C4 II (B7)

1.2 THP 110; 1.2 THP 130	04.14-	HNY (EB2DTS); HNZ (EB2DT); (81-96kW)		F-580958	535 0304 10	39
1.4 VTi 95; 1.6 THP 155; 1.6 VTi 120; 1.6 VTi 120 LPG	11.09-	5FS (EP6C); 5FV (EP6CDT); 8FP (EP3); (70-115kW)		 A/C	529 0266 10	38



C4 CACTUS

1.2 THP 110	09.14-	HNZ (EB2DT); (81kW)		F-580958	535 0304 10	39
-------------	--------	---------------------	---	----------	-------------	----



C4 Picasso (UA_, UD_)

1.6 16V; 1.6 THP 140; 1.6 THP 155; 1.6 VTi 120	07.08-08.13	5FT (EP6DT); 5FV (EP6CDT); 5FW (EP6); 5FX (EP6DT); (88-115kW)		 A/C	529 0266 10	38
1.6 HDi	10.06-08.13	9HY (DV6TED4); 9HZ (DV6TED4); (80kW)		→ORGA 10555	544 0079 20	39

C4 Picasso II

1.2 THP 110; 1.2 THP 130	04.14-	HNY (EB2DTS); HNZ (EB2DT); (81-96kW)		F-580958	535 0304 10	39
1.6 THP 150; 1.6 THP 155; 1.6 THP 165; 1.6 VTi 120	02.13-	5FS (EP6C); 5FV (EP6CDT); 5FX (EP6DT); 5GZ (EP6FDT); (88-121kW)		 A/C	529 0266 10	38

C5 (RE_, RC_, RD_, TD_)

1.6 HDi; 1.6 HDi 110	09.04-	9HY (DV6TED4); 9HZ (DV6TED4); (80kW)		→ORGA 10555	544 0079 20	39
1.6 THP 150; 1.6 THP 155; 1.6 VTi 120; 1.6 VTi 120	04.09-	5FN (EP6CDT); 5FS (EP6C); 5FV (EP6CDT); (88-115kW)		 A/C	529 0266 10	38



C15 (VD_)

1.9 D	12.00-12.05	WJX (DW8B); (44kW)		A/C	544 0087 20	39
-------	-------------	--------------------	--	-----	-------------	----



C-ELYSEE

1.2 VTi 72	11.12-	HMY (EB2M); (53kW)		F-580958	535 0304 10	39
1.2 VTi 82	12.14-	(60kW)		 EP2F / EB2M F-580958	535 0304 10	39



DS3

1.4 VTi 95; 1.4 VTi 95 LPG; 1.4 VTi 98; 1.6 Racing; 1.6 THP 150; 1.6 THP 155; 1.6 THP 165; 1.6 VTi 120	11.09-07.15	5FD (EP6DTS); 5FN (EP6CDT); 5FR (EP6DT); 5FS (EP6C); 5FU (EP6CDTX); 5FV (EP6CDT); 5FX (EP6DT); 5GZ (EP6FDT); 8FN (EP3); 8FP (EP3); 8FR (EP3); (70-152kW)		 A/C	529 0266 10	38
--	-------------	--	---	---	-------------	----

DS4

1.2 THP 130	07.14-07.15	HNY (EB2DTS); (96kW)		F-580958	535 0304 10	39
1.6 THP 155; 1.6 THP 160; 1.6 THP 200; 1.6 VTi 120	04.11-07.15	5FM (EP6DT); 5FS (EP6C); 5FU (EP6DTX); 5FV (EP6CDT); (88-147kW)		 A/C	529 0266 10	38

DS5

1.6 THP 155; 1.6 THP 165 Hybrid; 1.6 THP 200; 1.6 THP 210	11.11-07.15	5FU (EP6DTX); 5FV (EP6CDT); 5GM (EP6FDTX); 5GZ (EP6FDT); (115-155kW)		 A/C	529 0266 10	38
---	-------------	--	---	---	-------------	----

JUMPY I / DISPATCH I (BS_, BT_, BY_, BZ_, U6U)

1.9 D 70	04.98-10.06	WJY (DW8B); WJZ (DW8); (51kW)		A/C	544 0087 20	39
----------	-------------	-------------------------------	--	-----	-------------	----

CITROËN
SAXO (S0, S1)

1.0 X; 1.1 X,SX; 1.4 VTS; 1.6 VTL,VTR	05.96-09.03	CDZ (TU9M); HDZ (TU1M); HFX (TU1JP); KFW (TU3JP); KFX (TU3JP); NFZ (TU5JP); (33-65kW)			FB 5PK725	40
1.1 X,SX	05.96-09.03	HDZ (TU1M); (40kW)		80A	FB 5PK725	40
1.5 D	09.96-04.04	VJY (TUD5); VJZ (TUD5); (40-43kW)		A/C,	529 0258 10	37
				A/C,	529 0259 10	37
1.6; 1.6 VTS	09.00-04.04	NFT (TU5JP); (72-74kW)		A/C	FB 5PK725	40

XANTIA (X1, X1)

1.9 D; 1.9 SD; 1.9 Turbo D; 2.1 Turbo D 12V	06.94-01.98	D8B (XUD9TF); D9B (XUD9A/L); DHW (XUD9SD); DHX (XUD9TF/BTF); DHY (XUD9TE/Y); DJZ (XUD9Y); P8C (XUD11BTE); (50-80kW)		→ORGA 06808, A/C,	529 0256 10	37
---	-------------	---	--	-------------------	-------------	----

XM (Y3, Y3, Y4, Y4)

2.0 i Turbo; 2.0 Turbo	09.92-06.94	RGY (XU10J2TE/Z); (104kW)		A/C	FB 5PK1153	40
2.0 Turbo	05.94-10.00	RGX (XU10J2TE); (108kW)		A/C, →05.95	FB 5PK1153	40

XSARA (N2, N0, N1)

1.4 HDi	01.03-08.05	8HX (DV4TD); (50kW)			544 0079 20	39
1.4 i; 1.6 16V; 1.6 i	04.97-08.05	KFW (TU3JP); KFX (TU3JP); NFU (TU5JP4); NFZ (TU5JP); (55-80kW)		→ORGA 09155, A/C	529 0257 10	37
1.5 D	04.97-09.00	VJZ (TUD5); (42kW)		A/C,	529 0258 10	37
				A/C,	529 0259 10	37
1.8 D; 1.9 D; 1.9 SD; 1.9 TD	04.97-09.00	161A (XUD7); A9A (XUD7); DHV (XUD9BSD); DHY (XUD9TE/Y); DJY (XUD9A); (43-66kW)		A/C,	529 0256 10	37
1.9 D	07.98-08.05	WJY (DW8B); WJZ (DW8); (51kW)		A/C	544 0087 20	39

XSARA PICASSO (N68)

1.6	12.99-	NFV (TU5JP); NFZ (TU5JP); (65-70kW)		→ORGA 09162, A/C	529 0257 10	37
1.6 HDi	05.04-	9HY (DV6TED4); 9HZ (DV6TED4); (80kW)		→ORGA 10569	544 0079 20	39
1.6 HDi	09.05-	9HX (DV6ATED4); (66kW)		→ORGA 10562	544 0079 20	39

ZX (N2, N2)

1.8 D; 1.9 D; 1.9 DT; 1.9 TD	03.91-10.97	161A (XUD7); D9B (XUD9A/U); DHY (XUD9TE/Y); DJY (XUD9A); DJZ (XUD9Y); (44-68kW)		→ORGA 05956, ORGA 07056→, A/C,	529 0256 10	37
------------------------------	-------------	---	--	--------------------------------	-------------	----

DACIA
DOKKER Express / DOKKER

1.2 TCe; 1.2 TCe 115	11.12-	H5F 402; (84-85kW)		02.14→	FB 7PK1570	42
				→01.14	FB 7PK1605	42
1.2 TCe 115	07.15-	(85kW)			FB 7PK1570	42

DUSTER

1.2 TCe 125	10.13-	H5F 404; (92kW)		02.14→	FB 7PK1570	42
				→01.14	FB 7PK1605	42
1.2 TCe 125 4x4	06.15-	H5F 410; (92kW)			FB 7PK1570	42
1.5 dCi; 1.5 dCi 4x4; 1.6 16V; 1.6 16V 4x4; 1.6 16V LPG	04.10-	K4M 606; K4M 690; K4M 696; K9K 796; K9K 830; K9K 884; K9K 892; K9K 894; K9K 896; (63-79kW)			544 0090 20	39

LODGY

1.2 TCe	03.12-	H5F 402; (85kW)		02.14→	FB 7PK1570	42
				→01.14	FB 7PK1605	42
1.5 dCi	03.12-	K9K 612; (66kW)			544 0090 20	39

LOGAN (LS, KS, FS, US)

1.5 dCi; 1.6 16V; 1.6 16V Hi-Flex	09.05-	K4M 690; K4M 696; K9K 790; K9K 792; K9K 796; K9K 892; (48-77kW)			544 0090 20	39
-----------------------------------	--------	---	--	--	-------------	----

LOGAN II

1.5 dCi	10.12-	K9K 612; K9K 626; K9K 830; (55-66kW)			544 0090 20	39
TCe 90	10.12-	H4B 400; H4B 408; (66kW)		02.14→	FB 7PK1570	42
				→01.14	FB 7PK1605	42
TCe 90 LPG	09.15-	H4B 405; H4B 410; (66kW)		H4B410	FB 7PK1570	42

SANDERO

1.5 dCi; 1.6 16V; 1.6 16V Bifuel	11.08-	K4M 690; K4M 694; K4M 696; K9K 792; K9K 796; K9K 892; (50-77kW)			544 0090 20	39
----------------------------------	--------	---	--	--	-------------	----

SANDERO II

TCe 90	10.12-	H4B 400; (66kW)		02.14→	FB 7PK1570	42
				→01.14	FB 7PK1605	42
TCe 90 LPG	09.15-	(66kW)			FB 7PK1570	42

DODGE
CARAVAN (RG)

2.4	02.00-12.07	EDZ; (111kW)			FB 6PK1250	41
-----	-------------	--------------	--	--	------------	----



DS

DS5

1.6 THP 165; 1.6 THP 210	04.15-	5GM (EP6FDTX); 5GZ (EP6FDT); (121-155kW)			A/C	529 0266 10	38
--------------------------	--------	--	--	--	-----	-------------	----

DS 3 / DS 3 Décapotable / DS 4 / DS 4 CROSSBACK

1.2 THP 130	07.15-	HNY (EB2DTS); (96kW)			F-580958	535 0304 10	39
1.6 THP 165; 1.6 THP 208; 1.6 THP 210	07.15-	5GM (EP6FDTX); 5GR (EP6FDTX); 5GZ (EP6FDT); (121-155kW)			A/C	529 0266 10	38

FIAT

500 (312_) / 500 C (312_)

1.3 D Multijet	10.07-	169 A1.000; 199 B1.000; 312 B1.000; (55-70kW)			A/C	529 0045 30	36
----------------	--------	---	--	--	-----	-------------	----

500L (351_, 352_)

1.3 D Multijet	09.12-	199 B4.000; 330 A1.000; (62-70kW)			F-583190	535 0311 10	39
					A/C	529 0045 30	36

500X (334_)

1.3 D Multijet	06.15-	55266963; (70kW)			F-583190	535 0311 10	39
----------------	--------	------------------	--	--	----------	-------------	----

BARCETTA (183_)

1.8 16V	04.95-05.05	183 A1.000; 188 A6.000; (96kW)			A/C, # OE 71739915	FB 6PK1845	41
---------	-------------	--------------------------------	--	--	--------------------	------------	----

BRAVO I / BRAVA (182_, 182_)

1.4; 1.4 12 V	10.95-10.01	182 A3.000; 182 A5.000; (55-59kW)			A/C	FB 6PK1845	41
1.8 GT	10.95-10.01	182 A2.000; (83kW)			A/C	FB 6PK1845	41
1.8 GT 16V	10.95-10.01	182 A2.000; (83kW)			A/C	FB 6PK1845	41

COUPE (175_)

1.8 16V	03.96-08.00	183 A1.000; (96kW)			A/C, # OE 71739915	FB 6PK1845	41
---------	-------------	--------------------	--	--	--------------------	------------	----

DOBLO (263_, 263_, 263_)

1.3 D Multijet	02.10-	199 A3.000; 225 A2.000; 263 A2.000; 263 A6.000; 330 A1.000; (55-70kW)			F-583190	535 0311 10	39
----------------	--------	---	--	--	----------	-------------	----

IDEA (350_)

1.3 D Multijet	01.04-12.12	188 A9.000; 199 A3.000; 199 B1.000; (51-70kW)			A/C,	529 0045 30	36
----------------	-------------	---	--	--	------	-------------	----

MAREA (185_, 185_)

1.4 80 12V	09.96-05.02	182 A3.000; (59kW)			A/C	FB 6PK1845	41
1.8 115 16V	09.96-05.02	182 A2.000; (83kW)			A/C	FB 6PK1845	41

PALIO Weekend (178_)

1.9 JTD	09.01-	188 A2.000; (59kW)			A/C	FB 6PK1845	41
---------	--------	--------------------	--	--	-----	------------	----

PANDA (312_, 319_)

1.3 D Multijet	02.12-	199 A1.000; 199 A9.000; (55kW)			A/C	529 0045 30	36
----------------	--------	--------------------------------	--	--	-----	-------------	----

PANDA (169_, 169_)

1.3 D Multijet; 1.3 D Multijet 4x4	09.03-	169 A1.000; 169 A5.000; 188 A8.000; 188 A9.000; (51-55kW)			A/C	529 0045 30	36
------------------------------------	--------	---	--	--	-----	-------------	----

PUNTO / GRANDE PUNTO (199_, 199_, 199_)

1.3 D Multijet	10.05-02.12	199 A2.000; 199 A9.000; 199 B1.000; 199 B2.000; 199 B4.000; 199 B8.000; (51-70kW)			A/C	529 0045 30	36
----------------	-------------	---	--	--	-----	-------------	----

PUNTO (188_, 188_)

1.3 JTD; 1.3 JTD 16V	06.03-03.12	188 A9.000; (51kW)			A/C	529 0045 30	36
1.8 130 HGT	09.99-03.12	183 A1.000; 188 A6.000; (96kW)			# OE 71739915	FB 6PK1845	41

STRADA Pick-up (178_)

1.9 JTD	04.03-	188 A2.000; (59kW)			A/C	FB 6PK1845	41
---------	--------	--------------------	--	--	-----	------------	----

TIPO 3/5 portes (357_) / TIPO A trois volumes (356_) / TIPO Break (357_)

1.3 D	10.15-	199 B1.000; 55266963; (70kW)			F-583190	535 0311 10	39
-------	--------	------------------------------	--	--	----------	-------------	----

FORD

B-MAX (JK)

1.0 EcoBoost	10.12-	M1JA; M1JE; SFJA; SFJB; SFJC; SFJD; (74-92kW)				FB 6PK1503	41
--------------	--------	---	--	--	--	------------	----

C-MAX (DM2)

1.6	02.07-09.10	HWDA; HWDB; SHDA; SHDB; SHDC; (74kW)			A/C	FB 5EPK868	40
1.6 TDCi	02.07-09.10	G8DA; G8DB; G8DC; G8DD; GPDA; HHDA; HHDB; MTDA; (66-80kW)				544 0079 20	39
1.8; 1.8 Flexifuel; 2.0; 2.0 CNG; 2.0 LPG	02.07-09.10	AODA; AODB; AODE; Q7DA; QQDA; QQDB; QQDC; SYDA; (90-107kW)			A/C	FB 5EPK705	40

C-MAX II (DXA/CB7, DXA/CEU)

1.0 EcoBoost	10.12-	M1DA; M2DA; SFDA; (74-92kW)				FB 6PK1503	41
1.6 Ti	12.10-	PNDA; (92kW)			A/C, , (HY)	FB 5EPK868	40

FORD
ECOSPORT

1.0 EcoBoost	10.13-	M1JC; (92kW)			FB 6PK1503	41
--------------	--------	--------------	--	--	------------	----

FIESTA V (JH_, JD_)

1.4 TDCi; 1.6 TDCi	11.01-06.08	F6JA; F6JB; HHJA; HHJB; (50-66kW)			544 0079 20	39
--------------------	-------------	-----------------------------------	--	--	-------------	----

FIESTA Van

1.4 TDCi; 1.6 TDCi	10.03-12.10	F6JA; F6JB; HHJC; HHJD; HHJE; (50-66kW)			544 0079 20	39
--------------------	-------------	---	--	--	-------------	----

FIESTA VI

1.0; 1.0 EcoBoost; 1.0 Sport	09.12-	M1JE; M1JH; P4JA; P4JB; P4JC; P4JD; SFJA; SFJB; SFJC; SFJD; XMJA; XMJB; YYJA; YYJB; (48-103kW)			FB 6PK1503	41
------------------------------	--------	--	--	--	------------	----

1.6 TDCi	06.08-	HHJC; HHJD; HHJE; (66kW)			544 0079 20	39
----------	--------	--------------------------	--	--	-------------	----

FOCUS II Décapotable

1.6	10.06-09.10	HWDA; HWDB; SHDA; SHDB; SHDC; (74kW)		A/C	FB 5EPK868	40
-----	-------------	--------------------------------------	--	-----	------------	----

2.0	10.06-09.10	AODA; AODB; (107kW)		A/C	FB 5EPK705	40
-----	-------------	---------------------	--	-----	------------	----

FOCUS II (DA_, DA_, HCP, DB_)

1.4; 1.6; 1.6 LPG; 1.6 Ti	07.04-09.12	ASDA; ASDB; HWDA; HWDB; HXDA; HXDB; SHDA; SHDB; SHDC; SIDA; (59-85kW)		A/C	FB 5EPK868	40
---------------------------	-------------	---	--	-----	------------	----

1.6 TDCi	07.04-09.12	G8DA; G8DB; G8DC; G8DD; G8DE; G8DF; GPDA; GPDB; GPDC; HHDA; HHDB; MTDA; (66-80kW)		→ 12.09	544 0079 20	39
----------	-------------	---	--	---------	-------------	----

1.8; 1.8 Flexifuel; 2.0; 2.0 CNG; 2.0 LPG	07.04-09.12	AODA; AODB; AODE; Q7DA; QQDA; QQDB; SYDA; (92-107kW)		A/C	FB 5EPK705	40
---	-------------	--	--	-----	------------	----

FOCUS III / FOCUS III Van / FOCUS III

1.0 EcoBoost	02.12-	M1DA; M2DA; (74-92kW)			FB 6PK1503	41
--------------	--------	-----------------------	--	--	------------	----

1.6 Flexifuel; 1.6 Ti	07.10-	IQDB; MUDA; PNDA; XTDA; (63-92kW)		A/C, , (HY)	FB 5EPK868	40
-----------------------	--------	-----------------------------------	--	-------------	------------	----

FOCUS (DNW, DAW, DBW, DFW)

1.4 16V; 1.6 16V	10.98-11.04	FXDA; FXDB; FXDC; FXDD; FYDA; FYDB; FYDC; FYDD; FYDH; (55-74kW)		A/C, 03.02 →	FB 6PK1915	41
------------------	-------------	---	--	---------------	------------	----

FOCUS C-MAX

1.6; 1.6 Ti	10.03-03.07	HWDA; HWDB; HXDA; SIDA; (74-85kW)		A/C	FB 5EPK868	40
-------------	-------------	-----------------------------------	--	-----	------------	----

1.6 TDCi	10.03-03.07	G8DA; G8DB; HHDA; HHDB; (66-80kW)			544 0079 20	39
----------	-------------	-----------------------------------	--	--	-------------	----

1.8	10.03-03.07	CSDA; CSDB; (88kW)		A/C, 12.03 →	FB 5EPK705	40
-----	-------------	--------------------	--	---------------	------------	----

1.8; 1.8 Flexifuel; 2.0	03.04-03.07	AODA; AODB; Q7DA; QQDA; QQDB; SYDA; (92-107kW)		A/C	FB 5EPK705	40
-------------------------	-------------	--	--	-----	------------	----

FUSION (JU_)

1.4 TDCi; 1.6 TDCi	08.02-12.12	F6JA; F6JB; HHJA; HHJB; (50-66kW)			544 0079 20	39
--------------------	-------------	-----------------------------------	--	--	-------------	----

GRAND C-MAX (DXA/CB7, DXA/CEU)

1.0 EcoBoost	10.12-	M1DA; M2DA; SFDA; (74-92kW)			FB 6PK1503	41
--------------	--------	-----------------------------	--	--	------------	----

1.6 Ti	12.10-	PNDA; (92kW)		A/C, , (HY)	FB 5EPK868	40
--------	--------	--------------	--	-------------	------------	----

KA (RU8)

1.3 TDCi	10.08-	FD4; (55kW)		A/C	529 0045 30	36
----------	--------	-------------	--	-----	-------------	----

MONDEO III (BWY, B4Y, B5Y)

2.0 16V DI / TDi / TDCi; 2.0 16V TDDi / TDCi; 2.0 TDCi; 2.2 TDCi	10.00-03.07	D5BA; D6BA; FMBA; HJBA; HJBB; HJBC; N7BA; QJBA; QJBB; QJBC; QJBD; SDBA; (66-114kW)			529 0250 10	37
--	-------------	--	--	--	-------------	----

MONDEO IV (BA7, BA7, BA7)

2.0 TDCi	03.07-01.15	AZBA; KLBA; LPBA; QXBA; QXBB; TXBA; TXBB; TYBA; UFBA; UFBB; (85-120kW)			FB 6PK1845	41
----------	-------------	--	--	--	------------	----

2.0 TDCi	03.07-01.15	AZBC; UKBA; UKBB; (100kW)			FB 6PK1845	41
----------	-------------	---------------------------	--	--	------------	----

TRANSIT / TOURNEO CONNECT

1.0 EcoBoost	02.13-	M2GA; M2GB; (74kW)			FB 6PK1503	41
--------------	--------	--------------------	--	--	------------	----

TRANSIT / TOURNEO COURIER

1.0 EcoBoost	02.14-	SFCA; SFCB; SFCC; SFCD; (74kW)			FB 6PK1503	41
--------------	--------	--------------------------------	--	--	------------	----

TRANSIT VI / TRANSIT TOURNEO

2.3 16V [RWD]	04.06-08.14	GZFA; GZFB; GZFC; (107kW)		A/C	FB 6PK2280	41
---------------	-------------	---------------------------	--	-----	------------	----

2.4 TDCi; 2.4 TDCi [RWD]; 2.4 TDCi 4x4; 3.2 TDCi; 3.2 TDCi [RWD]	04.06-08.14	H9FB; JXFA; JXFC; PHFA; PHFC; SAFA; SAFB; (74-147kW)		A/C	FB 7PK2683	43
--	-------------	--	--	-----	------------	----

2.4 TDCi; 2.4 TDCi [RWD]; 2.4 TDCi 4x4	04.06-08.14	H9FB; H9FD; PHFA; PHFC; (74-103kW)		A/C, # OE 1376751	FB 7PK2683	43
--	-------------	------------------------------------	--	-------------------	------------	----

				A/C	FB 7PK2843	43
--	--	--	--	-----	------------	----

TRANSIT V (FD_, FB_, FS_, FZ_, FC_, FA_, FM_, FN_)

2.0 Di; 2.0 TDCi	08.00-05.06	ABFA; D3FA; F3FA; F5FA; (55-92kW)			529 0250 10	37
------------------	-------------	-----------------------------------	--	--	-------------	----

HONDA
ACCORD IX (CW, CU)

2.4 i	07.08-06.15	K24Z3; (148kW)			FB 7PK1715	42
-------	-------------	----------------	--	--	------------	----



HYUNDAI



HONDA

CIVIC VIII (FN, FK, FD, FA)

1.8; 1.8 EXS Flex	09.05-	R18A1; R18A2; (103kW)			→MY 2006, A/C	529 0152 10	36
-------------------	--------	-----------------------	--	--	---------------	-------------	----

JAZZ II (GD_, GE3, GE2)

1.2 I-DSI; 1.3	03.02-07.08	L12A1; L12A4; L13A1; (57-61kW)			↔BM 2004<, A/C	FB 5PK1153	40
----------------	-------------	--------------------------------	--	--	----------------	------------	----

LOGO (GA)

1.3	03.99-03.02	D13B7; (48kW)				FB 3PK890	40
-----	-------------	---------------	--	--	--	-----------	----

HYUNDAI

GRANDEUR (TG)

3.3	04.05-12.10	G6DB; (173kW)				FB 6PK2478	42
-----	-------------	---------------	--	--	--	------------	----

H-1 Camionnette

2.5 CRDi	07.01-04.04	D4CB; (81kW)			↔BM H1, A/C	FB 7PK2285	42
----------	-------------	--------------	--	--	--------------	------------	----

2.5 CRDi	08.03-12.07	D4CB; (103kW)			↔BM H200, A/C	FB 7PK2285	42
----------	-------------	---------------	--	--	----------------	------------	----

					↔BM H1, A/C		
--	--	--	--	--	--------------	--	--

H-1 (TQ, TQ)

2.5 CRDi; 2.5 CRDi	02.08-	D4CB; D4CB-L; D4CB-W; (81-125kW)			A/C	FB 7PK1715	42
--------------------	--------	----------------------------------	--	--	-----	------------	----

2.5 CRDi	02.08-	D4CB; (125kW)			↔BM iLoad, A/C	FB 7PK2285	42
----------	--------	---------------	--	--	-----------------	------------	----

2.5 CRDi	08.11-	D4CB; (85kW)			↔BM H1, A/C	FB 7PK2285	42
----------	--------	--------------	--	--	--------------	------------	----

PORTER Camionnette

2.5 CRDi	02.03-04.04	D4CB; (103kW)			A/C	FB 7PK2285	42
----------	-------------	---------------	--	--	-----	------------	----

SATELLITE

2.5 CRDi; 2.5 CRDi 4WD	12.02-04.04	D4CB; (103-120kW)			A/C	FB 7PK2285	42
------------------------	-------------	-------------------	--	--	-----	------------	----

2.5 CRDi	12.02-04.04	D4CB; (103kW)			↔BM Starex, A/C	FB 7PK2285	42
----------	-------------	---------------	--	--	------------------	------------	----

					↔BM H1, A/C		
--	--	--	--	--	--------------	--	--

					↔BM Satellite, A/C		
--	--	--	--	--	---------------------	--	--

2.5 CRDi	06.06-12.07	D4CB; (81kW)			↔BM Satellite, A/C	FB 7PK2285	42
----------	-------------	--------------	--	--	---------------------	------------	----

					↔BM H1, A/C		
--	--	--	--	--	--------------	--	--

					↔BM H200, A/C		
--	--	--	--	--	----------------	--	--

SONATA V (NF)

3.3	01.05-12.10	G6DB; (171-184kW)			A/C	FB 6PK2478	42
-----	-------------	-------------------	--	--	-----	------------	----

INFINITI

QX70

3.7 AWD	08.13-	VQ37VHR; (235kW)				FB 7PK2672	42
---------	--------	------------------	--	--	--	------------	----

30d AWD; 50 AWD	08.13-	V9X; VK50VE; (175-287kW)				FB 7PK2672	42
-----------------	--------	--------------------------	--	--	--	------------	----

ISUZU

TROOPER III

3.5 V6 24V	04.00-08.04	G6E1; (158kW)			A/C	FB 6PK2285	42
------------	-------------	---------------	--	--	-----	------------	----

JAGUAR

XF (CC9_) / XF SPORTBRAKE (CC9_)

3.0 D	03.09-04.15	306DT; AJV6D; (155-202kW)				FB 6PK2305	42
-------	-------------	---------------------------	--	--	--	------------	----

XJ (X351_)

3.0 D	10.09-12.15	AJV6D; (202kW)				FB 6PK2305	42
-------	-------------	----------------	--	--	--	------------	----

X-TYPE (CF1_, CF1_)

2.0 D; 2.2 D	07.03-12.09	FMBA; FMBB; LJ46G; R4-X404; (96-114kW)				529 0250 10	37
--------------	-------------	--	--	--	--	-------------	----

JEEP

CHEROKEE (XJ)

2.5; 2.5 i 4x4; 2.5 SE	10.84-09.01	EPE; (87-89kW)			A/C, RHD	FB 6PK1980	41
------------------------	-------------	----------------	--	--	----------	------------	----

4.0 i; 4.0 i 4x4	01.88-09.01	ERH; MX; (131-136kW)			LHD, →12.95	FB 6PK2478	42
------------------	-------------	----------------------	--	--	-------------	------------	----

GRAND CHEROKEE I (ZJ)

4.0 i 4x4; 4.0 Laredo	10.95-04.99	ERH; S01; (130-131kW)			A/C	FB 6PK2285	42
-----------------------	-------------	-----------------------	--	--	-----	------------	----

4.0 i 4x4	09.91-04.99	ERH; MX; (132-135kW)			→01.97→, RHD	FB 6PK2280	41
-----------	-------------	----------------------	--	--	--------------	------------	----

					A/C	FB 6PK2285	42
--	--	--	--	--	-----	------------	----

5.2 i 4x4	01.92-04.99	ELF; Y; (155-158kW)			↔BM 1992,1993,1994	FB 7PK2285	42
-----------	-------------	---------------------	--	--	--------------------	------------	----

WRANGLER II (TJ)

3.8	02.06-12.08	EGT; (153kW)			A/C	FB 6PK2280	41
-----	-------------	--------------	--	--	-----	------------	----

					A/C	FB 6PK2285	42
--	--	--	--	--	-----	------------	----

WRANGLER III (JK)

3.8	04.07-	EGT; (146kW)			A/C	FB 6PK2285	42
-----	--------	--------------	--	--	-----	------------	----

KIA

OPIRUS (GH)

3.8 V6	10.06-	G6DA; (196kW)				FB 6PK2478	42
--------	--------	---------------	--	--	--	------------	----

KIA

SORENTO I (JC)						
2.5 CRDi	08.02-	D4CB; (103kW)			→11.03,	FB 7PK2285 42

LANCIA
MUSA (350_)

1.3 D Multijet	10.04-09.12	188 A9.000; 199 A3.000; 199 B1.000; (51-70kW)			A/C	529 0045 30 36
----------------	-------------	---	--	--	-----	----------------

THEMA (834_)

2850 V6 i.e.	11.84-05.92	834 E.000; 834 E.146; (108-110kW)				FB 7PK1715 42
--------------	-------------	-----------------------------------	--	--	--	---------------

Y (840_)

1.4 12V	03.96-09.03	840 A2.000; 840 A4.000; (55-59kW)			A/C	FB 6PK1845 41
---------	-------------	-----------------------------------	--	--	-----	---------------

YPSILON (312_, 843_)

1.3 D Multijet	09.06-12.11	199 A2.000; 199 A3.000; 199 B1.000; 312 B1.000; (55-70kW)			A/C	529 0045 30 36
----------------	-------------	---	--	--	-----	----------------

LAND ROVER
DEFENDER (LD_, LD_, LD_, LD_)

2.2 Td4 4x4	08.11-02.16	ZSD-422; (90kW)				FB 7PK2672 42
2.5 Td5 4x4	06.98-02.16	10 P; 15 P; (90kW)				FB 7PK1715 42
2.5 Td5 4x4	06.98-02.16	10 P; 14 P; 15 P; (90kW)			A/C	FB 7PK1715 42

DISCOVERY I (LJ_)

4.0 4x4	09.93-10.98	35 D; 36 D; (134kW)			A/C,	FB 7PK1855 42
---------	-------------	---------------------	--	--	------	---------------

DISCOVERY II (LT_)

2.5 Td5 4x4	01.99-06.04	10 P; 15 P; (102kW)			A/C,	FB 7PK1715 42
4.0 V8 4x4	11.98-06.04	35 D; 56 D; 94 D; (136kW)			→12.98,	FB 7PK1855 42

DISCOVERY III (LA_)

2.7 TD 4x4	07.04-09.09	276DT; (140kW)				FB 8PK2093 43
------------	-------------	----------------	--	--	--	---------------

DISCOVERY IV (LA_)

2.7 TD 4x4	09.09-	276DT; (140kW)				FB 8PK2093 43
------------	--------	----------------	--	--	--	---------------

FREELANDER (LN_)

2.0 Td4 4x4	11.00-10.06	204D3; M 47; (82kW)			A/C,	529 0253 10 37
2.0 Td4 4x4	03.01-10.06	204D3; (80kW)			A/C,	529 0253 10 37

RANGE ROVER SPORT (LS_)

2.7 D 4x4	02.05-03.13	276DT; (140kW)			# OE PQS500370	FB 8PK2093 43
-----------	-------------	----------------	--	--	----------------	---------------

LEXUS
IS I (JCE1_, GXE1_) / IS SportCross

200	04.99-10.05	1G-FE; (114kW)				FB 3PK890 40
-----	-------------	----------------	--	--	--	--------------

MAZDA
2 (DY)

1.4 CD	04.03-06.07	F6JA; F6JB; (50kW)				544 0079 20 39
--------	-------------	--------------------	--	--	--	----------------

3 (BK, BK)

1.6 DI Turbo	06.04-06.09	Y601; (80kW)				544 0079 20 39
--------------	-------------	--------------	--	--	--	----------------

6 (GG, GG, GH, GH, GH)

2.0 MZR; 2.5 MZR	08.07-07.13	L5-VE; LF17; LF-DE; (108-125kW)				FB 6PK2285 42
2.3	06.02-08.07	L3C1; (122kW)			A/C,	FB 6PK2305 42
2.3	08.02-08.07	L3C1; (122kW)			A/C	FB 6PK2305 42

6 Station Wagon (GY)

2.3	08.02-08.07	L3C1; (122kW)			A/C	FB 6PK2305 42
2.3 AWD	11.02-08.07	L3C1; (119kW)			A/C,	FB 6PK2305 42

CX-7 (ER)

2.3 MZR DISI Turbo	10.07-03.13	L3-VDT; (190-191kW)			AUTOM	FB 6PK2285 42
--------------------	-------------	---------------------	--	--	-------	---------------

MPV II (LW)

2.3	07.02-02.06	L3; (104kW)				FB 6PK2285 42
-----	-------------	-------------	--	--	--	---------------

XEDOS 9 (TA)

2.3 24V	02.95-01.00	KJ -ZEM; (155kW)				FB 7PK1605 42
---------	-------------	------------------	--	--	--	---------------

MERCEDES-BENZ
190 (W201)

2.0; E 2.0	10.82-06.93	M 102.921; M 102.961; M 102.962; (66-90kW)			A/C,	FB 6PK1980 41
------------	-------------	--	--	--	------	---------------



MERCEDES-BENZ

190 (W201)

2.0; E 2.0; E 2.3; E 2.3-16; E 2.5-16	04.84-08.93	M 102.924; M 102.961; M 102.962; M 102.983; M 102.985; M 102.990; M 102.991; (75-150kW)		A/C	FB 6PK1980	41
E 1.8	04.90-08.93	M 102.910; (80kW)		A/C	FB 6PK1980	41

CLASSE V (W447)

V 200 CDI / d; V 200 CDI / d 4-matic; V 220 CDI / d; V 220 CDI / d 4-matic; V 250 BlueTEC / d; V 250 BlueTEC / d 4-matic	03.14-	OM 651.950; (100-140kW)			534 0611 10	38
--	--------	-------------------------	--	--	-------------	----

CLASSE A (W169)

A 150; A 160; A 170; A 180	09.04-06.12	M 266.920; M 266.940; (70-85kW)		START/STOP, A/C	529 0233 10	36
				START/STOP, A/C	FB 6PK1986	41

CLASSE B (W245)

B 150; B 160; B 170; B 180	03.05-11.11	M 266.920; M 266.940; (70-85kW)		START/STOP, A/C	529 0233 10	36
				START/STOP, A/C	FB 6PK1986	41

CLASSE C (W205)

C 180 BlueTEC / d; C 200 BlueTEC / d	05.14-	OM 626.951; (85-100kW)			534 0624 10	38
--------------------------------------	--------	------------------------	--	--	-------------	----

CLASSE C T-Model (S205)

C 180 BlueTEC / d; C 200 BlueTEC / d	09.14-	OM 626.951; (85-100kW)			534 0624 10	38
--------------------------------------	--------	------------------------	--	--	-------------	----

E-KLASSE/CLASS (W124, W124)

200; 200 E; 230 E; 230 E Cat	12.84-06.93	M 102.922; M 102.963; M 102.982; (75-100kW)		A/C	FB 6PK1980	41
280 E; E 280	10.92-06.95	M 104.942; (142-145kW)		A/C, MANU, 005790→	FB 6PK2478	42
				A/C, AUTOM, 048697→		
300 E-24	09.88-08.92	M 104.980; (162kW)		A/C, MANU, 004957→, →009076, without catalyst	FB 6PK2285	42
				A/C, AUTOM, 021005→, →042810, without catalyst		
320 E	10.92-06.93	M 104.992; (162kW)		A/C, MANU, 004357→, →005602	FB 6PK2478	42
				A/C, AUTOM, 072237→, →102820		
E 320	06.93-06.95	M 104.992; (162kW)		A/C, MANU, 004357→, →005602	FB 6PK2478	42
				A/C, AUTOM, 072237→, →102820		

E-KLASSE/CLASS (S124, S124)

200 T; 200 TE; 230 TE; 230 TE Cat	09.85-08.92	M 102.922; M 102.962; M 102.963; M 102.982; (77-100kW)		A/C	FB 6PK1980	41
230 TE	09.85-08.92	M 102.982; (97kW)		A/C	FB 6PK1980	41
280 TE; E 280 T	10.92-06.96	M 104.942; (142-145kW)		A/C, MANU, 005790→	FB 6PK2478	42
				A/C, AUTOM, 048697→		
300 TE-24; E 300 TE-24 AMG	09.89-06.96	M 104.980; (162kW)		A/C, MANU, 004957→, →009076, without catalyst	FB 6PK2285	42
				A/C, AUTOM, 021005→, →042810, without catalyst		
320 TE; E 320 T	10.92-06.96	M 104.992; (162kW)		A/C, MANU, 004357→, →005602	FB 6PK2478	42
				A/C, AUTOM, 072237→, →102820		

CLASSE E Coupé (C124)

E 320	06.93-06.97	M 104.992; (162kW)		A/C, MANU, 004357→, →005602	FB 6PK2478	42
				A/C, AUTOM, 072237→, →102820		

E-KLASSE/CLASS (A124, A124)

300 CE-24	04.92-06.93	M 104.980; (162kW)		A/C, MANU, 004957→, →009076, without catalyst	FB 6PK2285	42
				A/C, AUTOM, 021005→, →042810, without catalyst		

MERCEDES-BENZ
E-KLASSE/CLASS (A124, A124)

E 320	06.93-03.98	M 104.992; (162kW)		A/C , MANU , 004357→, →005602 A/C , AUTOM , 072237→, →102820	FB 6PK2478	42
-------	-------------	--------------------	--	---	-------------------	----

CLASSE S (W220)

S 400 CDI	06.00-08.05	OM 628.960; (184-191kW)		# OE 0149971692	FB 7PK2285	42
-----------	-------------	-------------------------	--	-----------------	-------------------	----

COUPE (C124)

230 CE	03.87-12.92	M 102.982; (97kW)		A/C	FB 6PK1980	41
230 CE; 230 CE Cat	03.87-12.92	M 102.982; (97-100kW)		A/C	FB 6PK1980	41
300 CE-24	09.89-12.92	M 104.980; (162kW)		A/C , MANU , 004957→, →009076, without catalyst A/C , AUTOM , 021005→, →042810, without catalyst	FB 6PK2285	42
320 CE	10.92-05.93	M 104.992; (162kW)		A/C , MANU , 004357→, →005602 A/C , AUTOM , 072237→, →102820	FB 6PK2478	42

SL (R129)

300 SL-24	03.89-07.93	M 104.981; (170kW)		A/C , MANU , 000940→, →001590, without catalyst A/C , AUTOM , 009206→, →014273, without catalyst	FB 6PK2285	42
-----------	-------------	--------------------	--	---	-------------------	----

Sprinter (906, 906, 906, 906, 906, 906, 906, 906)

209 CDI	06.06-12.09	OM 646.984; (65kW)		 avec prise de mouvement pour moteur	FB 6PK2280	41
209 CDI; 315 CDI	06.06-12.09	OM 646.984; OM 646.986; OM 646.989; OM 646.990; (65-110kW)		 avec prise de mouvement pour moteur	FB 6PK2285	42
211 CDI; 213 CDI; 311 CDI; 313 CDI; 511 CDI	06.06-05.16	OM 646.985; OM 646.986; (80-95kW)		A/C	FB 6PK2285	42
213 CDI; 215 CDI; 315 CDI; 515 CDI	06.06-12.09	OM 646.986; OM 646.989; OM 646.990; (95-110kW)		x2 BM =2ND ACC	FB 6PK2285	42
213 CDI	03.09-05.16	OM 651.956; (95kW)		 avec prise de mouvement pour moteur START/STOP	FB 6PK2285	42
213 CDI	06.06-05.16	OM 651.955; OM 651.956; (95kW)		START/STOP	FB 6PK2285	42
309 CDI; 509 CDI	06.06-12.09	OM 646.984; (65kW)		 avec prise de mouvement pour moteur A/C	FB 6PK2285	42
313 CDI	06.06-	OM 646.986; (95kW)		A/C , OM 646.986	FB 6PK2285	42

T1/TN

410 D	11.88-06.95	OM 602.940; (70-72kW)		OM 602.940, 253308→, →340125	FB 6PK1980	41
-------	-------------	-----------------------	--	---------------------------------	-------------------	----

T1 (602, 602, 602)

308 D 2.3	06.89-02.96	OM 601.940; (60kW)		253307→	FB 6PK1980	41
308 D 2.3	05.90-02.96	OM 601.940; (58kW)		→06.95, 253307→	FB 6PK1980	41
310 D 2.9	06.89-02.96	OM 602.940; (70-72kW)		OM 602.940, 253308→, →340125	FB 6PK1980	41

T1 (601, 601, 601, 611)

208 D 2.3	10.88-02.96	OM 601.940; (58-60kW)		253308→	FB 6PK1980	41
208 D 2.3; 210 2.3	04.77-02.96	M 102.942; M 102.946; M 115.955; OM 601.940; (58-70kW)		A/C	FB 6PK1980	41
210 2.3	04.77-10.89	M 102.942; (70kW)		WP , FAN , A/C ,	FB 6PK1980	41
210 D 2.8; 210 D 2.9	10.88-02.96	OM 602.940; (70-72kW)		OM 602.940, 253308→, →340125	FB 6PK1980	41

T2/L Camionnette/Break

L 410	08.82-12.88	M 102.943; (70kW)		A/C	FB 6PK1980	41
-------	-------------	-------------------	--	------------	-------------------	----

VIANO (W639)

CDI 2.0; CDI 2.0 4-matic; CDI 2.2; CDI 2.2 4-matic	09.03-	OM 646.980; OM 646.982; (80-110kW)		158570→, avec prise de mouvement pour moteur	FB 6PK2280	41
CDI 2.0	08.05-	OM 646.982; (85kW)		x2	FB 6PK2285	42

VITO (W639, W639)

109 CDI; 111 CDI; 111 CDI 4x4; 115 CDI; 115 CDI 4x4	09.03-	OM 646.980; OM 646.982; OM 646.983; (65-110kW)		158570→, avec prise de mouvement pour moteur	FB 6PK2280	41
109 CDI; 109 CDI 4x4	08.06-	OM 646.980; OM 646.981; (70kW)		A/C , 158570→	FB 6PK2285	42

VITO (W447, W447, W447)

109 CDI / 109 BlueTEC; 109 CDI; 111 CDI / 111 BlueTEC; 111 CDI	10.14-	OM 622.951; (65-84kW)			534 0624 10	38
---	--------	-----------------------	--	--	--------------------	----



MERCEDES-BENZ
VITO (W447, W447, W447)

114 CDI / 114 BlueTEC; 114 CDI / 114 BlueTEC 4x4; 114 CDI; 114 CDI 4x4; 116 CDI / 116 BlueTEC; 116 CDI / 116 BlueTEC 4x4; 116 CDI; 116 CDI 4x4; 119 BlueTEC; 119 BlueTEC 4x4; 119 CDI / 119 BlueTEC 4x4; 119 CDI / BlueTEC; 119 CDI / BlueTEC 4x4	10.14-	OM 651.950; (100-140kW)				534 0611 10	38
---	--------	-------------------------	--	--	--	-------------	----

MG
MG ZT- T / MG ZT

2.0 CDTi	06.02-07.05	204D2; (85-96kW)			A/C	529 0253 10	37
----------	-------------	------------------	--	--	-----	-------------	----

MINI
MINI (R56)

Cooper D; One D	11.06-09.10	9HZ (DV6TED4); W16 D16; (66-80kW)				544 0079 20	39
-----------------	-------------	-----------------------------------	--	--	--	-------------	----

MINI CLUBMAN (R55)

Cooper D	10.07-02.10	9HZ (DV6TED4); (80kW)				544 0079 20	39
----------	-------------	-----------------------	--	--	--	-------------	----

MITSUBISHI
GALANT VI (EA_, EA_)

2.0	09.96-09.00	4G63 (SOHC 16V); (100kW)			A/C, →02.98	FB 5PK1370	40
-----	-------------	--------------------------	--	--	--------------	------------	----

L 200 (K7_T, K6_T)

2.5 D; 2.5 TD 4WD	06.96-12.07	4D56 (8V); 4D56 T; 4D56 TD; (55-98kW)				544 0107 10	40
-------------------	-------------	---------------------------------------	--	--	--	-------------	----

PAJERO II Canvas Top (V2_W, V4_W)

2.5 TD 4WD	12.90-04.00	4D56 TD; (73kW)				544 0107 10	40
------------	-------------	-----------------	--	--	--	-------------	----

PAJERO SPORT I (K7_, K9_)

2.5 TD	11.98-	4D56 T; (73-98kW)				544 0107 10	40
--------	--------	-------------------	--	--	--	-------------	----

NISSAN
200 SX (S14)

2.0 i 16V Turbo	10.93-12.99	SR20DET; (147kW)				FB 3PK875	40
-----------------	-------------	------------------	--	--	--	-----------	----

CUBE (Z12)

1.6 16V	03.10-	HR16DE; (81kW)			←BM Z12, A/C	529 0272 10	38
---------	--------	----------------	--	--	--------------	-------------	----

JUKE (F15)

1.2 DIG-T	05.14-	HR12DDT; (85kW)			A/C	FB 7PK1605	42
-----------	--------	-----------------	--	--	-----	------------	----

MICRA I (K10)

1.0	12.82-12.89	MA10S; (37-40kW)			A/C	FB 3PK875	40
-----	-------------	------------------	--	--	-----	-----------	----

1.0	12.82-05.91	(43kW)			A/C	FB 3PK875	40
-----	-------------	--------	--	--	-----	-----------	----

MICRA III (K12)

160 SR	05.05-06.10	HR16DE; (81kW)			←BM K12E, A/C	529 0272 10	38
--------	-------------	----------------	--	--	---------------	-------------	----

MICRA C+C III (K12)

1.6 160 SR	08.05-	HR16DE; (81kW)			←BM CK12E, A/C	529 0272 10	38
------------	--------	----------------	--	--	----------------	-------------	----

NOTE (E11, NE11)

1.6	03.06-06.12	HR16DE; (81kW)			←BM E11E, A/C	529 0272 10	38
-----	-------------	----------------	--	--	---------------	-------------	----

NP300 NAVARA (D40)

3.0 dCi 4WD	02.10-	V9X; (170kW)				FB 7PK2672	42
-------------	--------	--------------	--	--	--	------------	----

NV200

1.6 16V	02.10-	HR16DE; (81kW)			←BM M20, A/C	529 0272 10	38
---------	--------	----------------	--	--	--------------	-------------	----

1.6 16V	07.10-	HR16DE; (81kW)			←BM M20M, A/C	529 0272 10	38
---------	--------	----------------	--	--	---------------	-------------	----

PATHFINDER III (R51)

3.0 dCi	08.10-	V9X; (170kW)				FB 7PK2672	42
---------	--------	--------------	--	--	--	------------	----

PRIMASTAR (X83, X83)

1.9 dCi 100; 1.9 dCi 80; dCi 100	03.01-	F9Q 760; F9Q 762; (60-74kW)			A/C	544 0101 20	39
----------------------------------	--------	-----------------------------	--	--	-----	-------------	----

dCi 80	03.01-	F9Q 762; (60kW)			H 38 mm, A/C	544 0101 20	39
--------	--------	-----------------	--	--	--------------	-------------	----

PULSAR 3/5 portes (C13)

1.2 DIG-T	10.14-	HR12DDT; (85kW)			A/C	FB 7PK1605	42
-----------	--------	-----------------	--	--	-----	------------	----

1.5 dCi	10.14-	K9K; (81kW)				544 0090 20	39
---------	--------	-------------	--	--	--	-------------	----

QASHQAI / QASHQAI +2 I (J10, JJ10)

1.6	02.07-12.13	HR16DE; (84-86kW)			A/C	FB 7PK1153	42
-----	-------------	-------------------	--	--	-----	------------	----

1.6 dCi; 1.6 dCi Traction intégrale	10.11-12.13	R9M; (96kW)				534 0624 10	38
-------------------------------------	-------------	-------------	--	--	--	-------------	----

QASHQAI II (J11, J11_)

1.2 DIG-T	11.13-	HR12DDT; (85kW)			A/C	FB 7PK1605	42
-----------	--------	-----------------	--	--	-----	------------	----

1.5 dCi	11.13-	K9K 636; (81kW)				544 0090 20	39
---------	--------	-----------------	--	--	--	-------------	----

1.6 dCi; 1.6 dCi ALL MODE 4x4-i	11.13-	R9M; (96kW)				534 0624 10	38
---------------------------------	--------	-------------	--	--	--	-------------	----

TIIDA 3/5 portes (C11)

1.6	09.07-12.11	HR16DE; (81kW)			←BM C11X, A/C	529 0272 10	38
-----	-------------	----------------	--	--	---------------	-------------	----

NISSAN
TIIDA A trois volumes (SC11)

1.6	09.07-12.12	HR16DE; (81kW)			↔BM SC11X, A/C	529 0272 10	38
-----	-------------	----------------	--	--	----------------	-------------	----

X-TRAIL (T32_)

1.6 dCi; 1.6 dCi ALL MODE 4x4-i	12.13-	R9M; (96kW)				534 0624 10	38
---------------------------------	--------	-------------	--	--	--	-------------	----

OPEL
ANTARA

2.4; 2.4 4x4	12.10-	A 24 XE; (123kW)				FB 6PK1980	41
--------------	--------	------------------	--	--	--	------------	----

ASTRA F (56_, 57_, 51_, 52_, 53_, 54_, 58_, 59_, 55_)

1.4 i; 1.4 Si; 1.6 i; 1.6 Si	09.91-09.98	C 14 NZ; C 14 SE; C 16 NZ; C 16 SE; X 14 NZ; X 16 SZR; (44-74kW)			☞→08.92	FB 5PK985	41
------------------------------	-------------	--	--	--	---------	-----------	----

ASTRA G (F67, F07_, F48_, F08_, F35_, F70, F69_)

1.4 16V; 1.6 16V; 1.6 CNG; 1.8 16V	02.98-10.05	C 16 SEL; X 14 XE; X 16 XEL; X 18 XE1; Z 14 XE; Z 16 XE; Z 16 YNG; Z 18 XE; (66-92kW)			A/C	FB 5PK1210	40
------------------------------------	-------------	---	--	--	-----	------------	----

1.6	02.98-04.05	X 16 SZR; Z 16 SE; (55-62kW)			A/C	FB 5PK1210	40
-----	-------------	------------------------------	--	--	-----	------------	----

1.7 DTI 16V	02.00-04.05	Y 17 DT; (55kW)			A/C	FB 6PK1250	41
-------------	-------------	-----------------	--	--	-----	------------	----

ASTRA H / ASTRA H GTC (L08, L70, L48, L69, L35, L67)

1.7 CDTi; 1.7 CDTI	02.07-05.14	A 17 DTJ; A 17 DTR; Z 17 DTJ; Z 17 DTR; (81-92kW)			A/C	FB 6PK1250	41
--------------------	-------------	---	--	--	-----	------------	----

1.8	01.04-10.10	Z 18 XE; (92kW)			A/C	FB 5PK1210	40
-----	-------------	-----------------	--	--	-----	------------	----

COMBO C

1.4; 1.4 16V	10.04-	Z 14 XEP; (66kW)			A/C	FB 5PK1370	40
--------------	--------	------------------	--	--	-----	------------	----

1.6; 1.6 CNG; 1.6 CNG 16V	10.01-	Z 16 SE; Z 16 YNG; (64-71kW)			A/C	FB 5PK1210	40
---------------------------	--------	------------------------------	--	--	-----	------------	----

1.7 DI 16V; 1.7 DTI 16V	10.01-	Y 17 DT; Y 17 DTL; (48-55kW)			A/C	FB 6PK1250	41
-------------------------	--------	------------------------------	--	--	-----	------------	----

COMBO D (X12, X12, X12)

1.3 CDTI	02.12-	A 13 FDI; B 13 DTC; (55-70kW)			F-583190	535 0311 10	39
----------	--------	-------------------------------	--	--	----------	-------------	----

CORSA C (F08, F68, F08, W5L)

1.2	09.00-12.09	Z 12 XE; (55kW)			A/C, ↔ 44001049→ A/C, ↔ 36152609→ A/C, ↔ 43xxxxxx→	FB 5PK1370	40
-----	-------------	-----------------	--	--	--	------------	----

1.2; 1.2 Twinport	07.04-12.09	Z 12 XEP; (59kW)			A/C, ↔ 36152609→	FB 5PK1370	40
-------------------	-------------	------------------	--	--	------------------	------------	----

1.4; 1.8	09.00-12.09	Z 14 XE; Z 18 XE; (66-92kW)			A/C	FB 5PK1210	40
----------	-------------	-----------------------------	--	--	-----	------------	----

1.4 Twinport	06.03-12.09	Z 14 XEP; (66kW)			A/C	FB 5PK1370	40
--------------	-------------	------------------	--	--	-----	------------	----

1.7 DI; 1.7 DI 16V; 1.7 DTI; 1.7 DTI 16V	09.00-12.09	Y 17 DT; Y 17 DTL; (48-55kW)			A/C	FB 6PK1250	41
--	-------------	------------------------------	--	--	-----	------------	----

CORSA D

1.7 CDTI	07.06-	Z 17 DTR; (92kW)			A/C	FB 6PK1250	41
----------	--------	------------------	--	--	-----	------------	----

FRONTERA B (6B_)

3.2 i	10.98-	6 VD1; Y 32 NE; (151kW)			A/C	FB 6PK2285	42
-------	--------	-------------------------	--	--	-----	------------	----

INSIGNIA (G09, G09, G09)

2.0 E85 Turbo; 2.0 Turbo; 2.0 Turbo 4x4; 2.0 Turbo E85	07.08-	A 20 NFT; A 20 NHT; (162-184kW)				FB 6PK1980	41
--	--------	---------------------------------	--	--	--	------------	----

MERIVA

1.4 16V Twinport	07.04-05.10	Z 14 XEP; (66kW)			A/C, ↔ 44001049→	FB 5PK1370	40
------------------	-------------	------------------	--	--	------------------	------------	----

1.4 16V Twinport LPG	07.04-05.10	Z 14 XEP; (66kW)			A/C, ↔ →19EH4453, ↔ 44001049→	FB 5PK1370	40
----------------------	-------------	------------------	--	--	----------------------------------	------------	----

1.6	05.03-05.10	Z 16 SE; (64kW)			A/C	FB 5PK1210	40
-----	-------------	-----------------	--	--	-----	------------	----

1.6 16V; 1.8	05.03-05.10	Z 16 XE; Z 18 XE; (74-92kW)			A/C	FB 5PK1210	40
--------------	-------------	-----------------------------	--	--	-----	------------	----

1.7 CDTI	09.03-05.10	Z 17 DT; Z 17 DTH; (74kW)			A/C, ↔ Z17DT	FB 6PK1250	41
----------	-------------	---------------------------	--	--	--------------	------------	----

1.7 CDTI; 1.7 DTI	09.03-05.10	A 17 DTR; Y 17 DT; Z 17 DTR; (55-92kW)			A/C	FB 6PK1250	41
-------------------	-------------	--	--	--	-----	------------	----

MONTEREY B

3.5 V6 24V	07.98-08.99	6 VE1; (158kW)			A/C	FB 6PK2285	42
------------	-------------	----------------	--	--	-----	------------	----

MOVANO A (F9, J9)

1.9 DTI	10.01-	F9Q 772; F9Q 774; (60kW)			A/C	544 0101 20	39
---------	--------	--------------------------	--	--	-----	-------------	----

TIGRA TwinTop

1.4	06.04-	Z 14 XEP; (66kW)			A/C	FB 5PK1370	40
-----	--------	------------------	--	--	-----	------------	----

1.8	06.04-	Z 18 XE; (92kW)			A/C	FB 5PK1210	40
-----	--------	-----------------	--	--	-----	------------	----

VIVARO Camionnette / VIVARO Camion plate-forme/Châssis / VIVARO Combi

1.6 CDTI	06.14-	R9M 408; R9M 413; R9M 450; R9M 452; (66-107kW)				534 0624 10	38
----------	--------	--	--	--	--	-------------	----

VIVARO (F7, J7, E7)

1.9 Di; 1.9 Di; 1.9 DTI	08.01-	F9Q 760; F9Q 762; (60-74kW)			A/C	544 0101 20	39
-------------------------	--------	-----------------------------	--	--	-----	-------------	----





OPEL

ZAFIRA A (F75_)

1.6 16V	04.99-06.05	X 16 XEL; Z 16 XE; (74kW)		A/C 100A, 22999999 →, A/C 100A, 2H999999 →, A/C	FB 5PK1210	40
1.6 CNG	09.01-06.05	Z 16 YNG; (71kW)		22999999 →, A/C 2H999999 →, A/C	FB 5PK1210	40
1.8 16V	04.99-06.05	X 18 XE1; Z 18 XE; (85-92kW)		120A, A/C	FB 5PK1210	40

ZAFIRA B (A05)

1.6 CNG	01.06-	Z 16 YNG; (69kW)		A/C	FB 5PK1210	40
1.7 CDTI	01.08-	A 17 DTJ; A 17 DTR; Z 17 DTJ; (81-92kW)		A/C	FB 6PK1250	41

PEUGEOT

106 I (1A, 1C)

1.4 D; 1.5 D	09.92-04.96	K9Y (TUD3Y); VJY (TUD5); VJZ (TUD5); (37-43kW)		A/C, A/C,	529 0258 10	37
					529 0259 10	37

106 II (1)

1.0 i; 1.1 i; 1.4 i; 1.6 i	05.96-07.04	CDY (TU9M); CDZ (TU9M); HDY (TU1M); HDZ (TU1M); HFX (TU1JP); KFW (TU3JP); KFX (TU3JP); NFZ (TU5JP); (33-65kW)			FB 5PK725	40
1.5 D	05.96-03.01	VJX (TUD5); VJY (TUD5); VJZ (TUD5); (40-42kW)		A/C, A/C,	529 0258 10	37
					529 0259 10	37

106 Van (1_)

1.5 D	10.00-03.01	VJX (TUD5); (42kW)		A/C, A/C,	529 0258 10	37
					529 0259 10	37

107

1.4 HDi	06.05-	8HT (DV4TD); (40kW)			544 0079 20	39
---------	--------	---------------------	--	--	-------------	----

108

1.0 VTi	05.14-	1KR-FE; (51kW)		A/C 	529 0262 10	37
					529 0268 10	38

206 (2E/K, 2A/C, 2D)

1.1; 1.1 i; 1.4 i; 1.6 16V; 1.6 i	08.98-12.00	HFX (TU1JP); HFY (TU1JP); HFZ (TU1JP); KFW (TU3JP); KFX (TU3JP); NFU (TU5JP4); NFZ (TU5JP); (40-80kW)		→ ORGA 09275, A/C A/C,	529 0257 10	37
					529 0260 10	37
1.1; 1.4; 1.6 16V	07.02-	HFX (TU1JP); KFW (TU3A); KFX (TU3JP); NFU (TU5JP4); (44-80kW)		A/C,	529 0260 10	37
1.4 HDi; 1.4 HDi eco 70; 1.6 HDi 110	09.01-03.09	8HX (DV4TD); 8HZ (DV4TD); 9HZ (DV6TED4); (50-80kW)		→ ORGA 10527	544 0079 20	39
1.9 D	09.98-05.07	WJY (DW8B); WJZ (DW8); (51kW)		A/C	544 0087 20	39

207 CC (WD_)

1.6 16V; 1.6 16V Turbo	02.07-	5FR (EP6DT); 5FS (EP6C); 5FV (EP6CDT); 5FW (EP6); 5FX (EP6DT); EP6; (88-115kW)		A/C	529 0266 10	38
------------------------	--------	---	--	-----	-------------	----

207 (WK_, WA_, WC_)

1.4 16V; 1.6 16V; 1.6 16V RC; 1.6 16V Turbo; 1.6 16V VTi	02.06-	5FR (EP6DT); 5FS (EP6C); 5FW (EP6); 5FX (EP6DT); 5FY (EP6DTS); 8FR (EP3); 8FS (EP3); EP3; EP3C; EP6; (70-128kW)		A/C	529 0266 10	38
---	--------	---	--	-----	-------------	----

208

1.4 GPL; 1.4 VTi; 1.6; 1.6 GTi	03.12-	5FS (EP6C); 5FU (EP6CDTX); 5FV (EP6CDT); 8FS (EP3); EP3C; (70-147kW)		A/C	529 0266 10	38
--------------------------------	--------	---	--	-----	-------------	----

301

1.2 VTi 72	11.12-	HMY (EB2M); (53kW)		F-580958	535 0304 10	39
1.2 VTi 82	12.14-	(60kW)		EP2F / EB2M F-580958	535 0304 10	39

306 (7E, N3, N5, 7A, 7C, N3, N5, 7B, N3, N5, N_, 7_)

1.8 D; 1.9 D; 1.9 DT; 1.9 SLD; 1.9 SRDT; 1.9 STD; 1.9 TD	05.93-04.02	A9A (XUD7); D8A (XUD9TE); DHV (XUD9BSD); DHY (XUD9TE); DJY (XUD9A); DJZ (XUD9Y); XUD9; (43-66kW)		ORGA 07247 →, A/C,	529 0256 10	37
---	-------------	--	--	--------------------	-------------	----

307 (3E, 3A/C, 3H)

1.4 HDi	10.01-	8HX (DV4TD); 8HZ (DV4TD); (50kW)			544 0079 20	39
1.4 HDi 70	03.02-01.05	8HZ (DV4TD); (50kW)		→ ORGA 10415	544 0079 20	39
1.6 HDi; 1.6 HDi 110; 1.6 HDi 110; 1.6 HDi 90	02.04-	9HV (DV6ATED4); 9HX (DV6ATED4); 9HY (DV6TED4); 9HZ (DV6TED4); (66-80kW)		→ ORGA 10555	544 0079 20	39

308 II

1.2 THP 110; 1.2 THP 130; 1.2 VTi 72	09.13-	HMZ (EB2F); HNY (EB2DTS); HNZ (EB2DT); (60-96kW)		F-580958	535 0304 10	39
1.6; 1.6 GTi; 1.6 THP 155; 1.6 THP 163	09.13-	5FM (EP6CDTM); 5FV (EP6CDT); 5GN (EP6FDTR); (115-200kW)		A/C	529 0266 10	38

PEUGEOT
308 I (4A_, 4C_)

1.4 16V; 1.6 16V; 1.6 GTi; 1.6 THP	09.07-	5FT (EP6DT); 5FV (EP6CDT); 5FW (EP6); 5FX (EP6DT); 5FY (EP6DTS); 8FR (EP3); 8FS (EP3); EP6; EP6CDTX; (70-147kW)		A/C	529 0266 10	38
1.6 HDi	09.07-	9HV (DV6ATED4); 9HX (DV6ATED4); (66kW)		→ORGA 10555	544 0079 20	39

309 II (3C, 3A)

1.9 GTI 16V	08.89-12.93	D6C (XU9J4); DFW (XU9J4); (108-116kW)			FB 5PK725	40
-------------	-------------	---------------------------------------	--	--	-----------	----

405 I (15E, 15B)

1.8 DT 4x4; 1.8 TD; 1.8 Turbo Diesel; 1.9 D; 1.9 Diesel	03.88-12.92	A8A (XUD7TE); AJZ (XUD7TEY); D9B (XUD9A); DJY (XUD9A); DJZ (XUD9Y); (47-66kW)		A/C,	529 0256 10	37
1.8 GLD	04.90-07.92	(44kW)		A/C, AUTOM	FB 5PK725	40
1.9 Sport MI-16; 1.9 SPort MI-16 4x4	07.87-12.92	D6C (XU9J4); DFW (XU9J4); (108-116kW)		A/C	FB 5PK725	40

405 II (4B, 4E)

1.9 D; 1.9 TD	08.92-10.96	DHY (XUD9TE); DJY (XUD9A); DJZ (XUD9Y); XUD9; (47-66kW)		A/C,	529 0256 10	37
---------------	-------------	---	--	------	-------------	----

407 (6D_, 6E_)

1.6 HDi 110	05.04-	9HZ (DV6TED4); (80kW)		→ORGA 10555	544 0079 20	39
-------------	--------	-----------------------	--	-------------	-------------	----

508

1.6 THP; 1.6 VTi	11.10-	5FH (EP6C); 5FS (EP6C); 5FV (EP6CDT); (85-115kW)		A/C	529 0266 10	38
------------------	--------	--	--	-----	-------------	----

1007 (KM_)

1.4 HDi	04.05-	8HX (DV4TD); 8HZ (DV4TD); (50kW)			544 0079 20	39
---------	--------	----------------------------------	--	--	-------------	----

2008

1.6 VTi	03.13-	5FS (EP6C); (88kW)		A/C	529 0266 10	38
---------	--------	--------------------	--	-----	-------------	----

3008

1.2	01.15-	HNY (EB2DTS); (96kW)		F-580958	535 0304 10	39
1.6 THP; 1.6 Turbo; 1.6 VTi	06.09-	5FS (EP6C); 5FV (EP6CDT); 5FW (EP6); 5FX (EP6DT); 5GZ (EP6FDT); EP6; (88-121kW)		A/C	529 0266 10	38

3008 SUV

1.2	05.16-	HNY (EB2DTS); (96kW)		EP2DTS F-580958	535 0304 10	39
-----	--------	----------------------	--	--------------------	-------------	----

5008

1.2	01.15-	HNY (EB2DTS); (96kW)		F-580958	535 0304 10	39
1.6 16V; 1.6 THP 163; 1.6 THP 165	09.09-	5FS (EP6C); 5FV (EP6CDT); 5FW (EP6); 5GZ (EP6FDT); EP6; (88-121kW)		A/C	529 0266 10	38

EXPERT Camionnette (222)

1.9 D 70	12.98-12.06	WJY (DW8B); WJZ (DW8); (51kW)		A/C	544 0087 20	39
----------	-------------	-------------------------------	--	-----	-------------	----

PARTNER (5, 5F)

1.1	06.96-09.05	HDZ (TU1M); HFX (TU1JP); (44kW)		A/C, # OE 5750.P5	FB 5PK725	40
1.2 THP	02.16-	HNV (EB2DTM); HNZ (EB2DT); (81kW)		F-580958	535 0304 10	39
1.4	06.96-12.15	KFX (TU3JP); TU32; (55kW)		A/C, →10.02	FB 5PK725	40
1.6	04.10-	5FK (EP6CB); 5FS (EP6C); (72-88kW)		A/C	529 0266 10	38
1.6 HDi 90	10.05-12.15	9HX (DV6ATED4); (66kW)		→ORGA 10562	544 0079 20	39
1.9 D; 1.9 D 4x4	12.98-07.08	WJY (DW8B); WJZ (DW8); (51kW)		A/C	544 0087 20	39

RCZ

1.6 16V; 1.6 THP 270	03.10-	5FG (EP6CDTR); 5FV (EP6CDT); EP6CDTX; (115-199kW)		A/C	529 0266 10	38
----------------------	--------	---	--	-----	-------------	----

PORSCHE
911 (996, 996)

3.6 GT2; 3.6 Turbo 4; 3.6 Turbo 4S	06.00-08.05	M 96.70; (309-355kW)			FB 6PK2285	42
------------------------------------	-------------	----------------------	--	--	------------	----

911 (997, 997)

3.6 GT 2; 3.6 GT2 RS; 3.6 Turbo; 3.8 Turbo; 3.8 Turbo S	03.06-12.12	M 97.70; M 97.70S; MA1.70; (353-456kW)			FB 6PK2285	42
---	-------------	--	--	--	------------	----

CAYENNE (9PA, 92A)

3.0 Diesel; 3.0 TDI	02.09-09.10	M 05.9D; M 05.9E; MCN.RB; (176kW)			FB 6PK2478	42
---------------------	-------------	-----------------------------------	--	--	------------	----

RENAULT
CAPTUR (J5_)

0.9 TcE 90	06.13-	H4B 400; (66kW)		02.14→ →01.14	FB 7PK1570 FB 7PK1605	42 42
1.2 TcE 120	06.13-	H5F 403; (88kW)		140128→, A/C	FB 7PK1570	42
1.2 TcE 120	01.16-	H5F 408; H5F 412; (87kW)		→01.14	FB 7PK1605	42
				140128→, A/C	FB 7PK1570	42
					FB 7PK1605	42





RENAULT

CAPTUR (J5_)

1.5 dCi 110; 1.5 dCi 90	06.13-	K9K 608; K9K 609; K9K 646; (66-81kW)			544 0090 20	39
-------------------------	--------	--------------------------------------	--	--	-------------	----

CLIO II (SB0/1/2_, BB0/1/2_, CB0/1/2_)

1.4 16V	10.99-09.04	K4J 712; K4J 713; (70kW)			544 0091 20	39
1.4 16V	08.00-	K4J 710; K4J 711; K4J 712; K4J 713; (72kW)		05.04→ K4J710;K4J712;K4J713, K4J711, A/C	544 0090 20	39
1.5 dCi	06.01-	K9K 700; K9K 702; K9K 704; K9K 712; (48-74kW)		05.04→	544 0090 20	39
1.5 dCi	08.04-	K9K 700; K9K 714; K9K 718; K9K 740; (47-62kW)			544 0090 20	39

CLIO IV (BH_, KH_)

0.9 TCe 90	11.12-	H4B 400; (66kW)		02.14→ 01.2014	FB 7PK1570	42
0.9 TCe 90	01.13-	H4B 400; (66kW)		02.14→	FB 7PK1605	42
1.2 TCe 120	03.13-	H5F 403; (88kW)		→01.14	FB 7PK1570	42
1.2 TCe 120	01.16-	H5F 412; (87kW)		140128→, A/C →01.14	FB 7PK1570	42
				140128→, A/C	FB 7PK1570	42
					FB 7PK1605	42

CLIO III (KR0/1_, BR0/1, CR0/1)

1.4 16V; 1.5 dCi; 1.6 16V	05.05-	K4J 780; K4M 800; K4M 801; K4M 804; K9K 714; K9K 752; K9K 764; K9K 766; K9K 768; K9K 770; K9K 772; K9K 774; (47-82kW)			544 0090 20	39
2.0 16V	09.06-	M4R 700; M4R 701; (102kW)		→12.14	529 0225 10	36

ESPACE III (JE0_)

2.0	11.96-10.00	F3R 728; F3R 729; F3R 742; F3R 768; F3R 769; (84kW)			544 0084 20	39
-----	-------------	---	--	--	-------------	----

ESPACE V (JR_)

1.6 dCi 130	06.15-	R9M 409; (96kW)			534 0624 10	38
-------------	--------	-----------------	--	--	-------------	----

FLUENCE (L30_)

1.5 dCi; 1.6 16V	02.10-	K4M 838; K4M 839; K9K 826; K9K 830; K9K 832; K9K 834; K9K 836; K9K 837; (63-81kW)			544 0090 20	39
1.6 dCi	07.14-	R9M 402; (96kW)			534 0624 10	38
2.0 16V	02.10-	M4R 714; M4R 751; (103kW)			529 0225 10	36

GRAND SCÉNIC II (JM0/1_)

1.5 dCi; 1.6	04.04-	K4M 761; K4M 782; K9K 728; (74-83kW)		05.04→	544 0090 20	39
1.6 Flex	06.06-11.08	K4M 766; (82kW)			544 0090 20	39

GRAND SCÉNIC III (JZ0/1_)

1.2 TCe	04.12-	H5F 400; H5F 404; (85-97kW)		140128→, A/C →01.14	FB 7PK1570	42
1.6 dCi	04.11-	R9M 402; R9M 404; (96kW)			FB 7PK1605	42
2.0 16V	02.09-	M4R 711; (103kW)			534 0624 10	38
					529 0225 10	36

KADJAR (HA_, HL_)

1.2 TCe 130	06.15-	H5F 408; (96kW)		A/C	FB 7PK1570	42
1.6 dCi 130; 1.6 dCi 130 4x4	06.15-	R9M 414; (96kW)			534 0624 10	38

KANGOO II (KW0/1_, KW0/1_, FW0/1_)

1.2 TCe 115	07.13-	H5F 400; (84kW)		A/C →01.14	FB 7PK1570	42
1.5 dCi; 1.5 dCi 110; 1.5 dCi 75; 1.5 dCi 85; 1.5 dCi 90; 1.6; 1.6 16V	02.08-	K4M 830; K4M 831; K9K 608; K9K 714; K9K 800; K9K 802; K9K 804; K9K 806; K9K 808; K9K 840; (50-80kW)			FB 7PK1605	42
1.6 16V Hi-Flex	02.08-	K4M 834; K4M 850; (78kW)			544 0090 20	39
					544 0091 20	39

KANGOO I (FC0/1_, KC0/1_)

1.5 dCi	12.01-	K9K 700; K9K 702; K9K 704; K9K 710; (42-60kW)		05.04→	544 0090 20	39
1.5 dCi	06.05-	K9K 714; K9K 716; K9K 718; (45-62kW)			544 0090 20	39
1.6 16V; 1.6 16V 4x4; 1.6 16V bivalent	06.01-	K4M 706; K4M 750; K4M 752; K4M 753; K4M 850; (60-70kW)			544 0091 20	39

LAGUNA I (K56_, B56_, 556_)

1.6 16V	11.97-03.01	K4M 720; K4M 724; (79kW)			544 0091 20	39
1.9 dCi	09.99-03.01	F9Q 718; (79kW)		A/C	544 0101 20	39
2.0	11.93-03.01	F3R 611; F3R 722; F3R 723; F3R 728; F3R 768; (80-84kW)			544 0084 20	39

LAGUNA II (BG0/1_) / LAGUNA II Grandtour (KG0/1_)

1.6 16V	03.01-	K4M 710; K4M 714; K4M 716; (79-82kW)			544 0091 20	39
---------	--------	--------------------------------------	--	--	-------------	----

RENAULT
LAGUNA II (BG0/1_) / LAGUNA II Grandtour (KG0/1_)

1.9 dCi; 1.9 dCi	03.01-09.07	F9Q 650; F9Q 670; F9Q 674; F9Q 718; F9Q 750; F9Q 752; F9Q 754; F9Q 758; F9Q 759; (77-92kW)		A/C	544 0101 20	39
------------------	-------------	--	--	-----	-------------	----

LAGUNA III Grandtour (KT0/1) / LAGUNA III (BT0/1)

2.0 16V; 2.0 16V Hi-Flex	10.07-	M4R 704; M4R 726; (103kW)			529 0225 10	36
2.0 16V Hi-Flex	10.07-	M4R 704; M4R 726; (103kW)		06.09→	529 0225 10	36

LATITUDE (L70_)

2.0 16V	02.11-	M4R 746; (103kW)			529 0225 10	36
---------	--------	------------------	--	--	-------------	----

LOGAN (KS_, LS_)

1.5 dCi; 1.6	04.07-	K4M 697; K9K 792; K9K 796; (50-77kW)			544 0090 20	39
--------------	--------	--------------------------------------	--	--	-------------	----

MEGANE I (EA0/1_, LA0/1_, JAO/1_, BA0/1_, DAO/1_, KA0/1_)

1.4 16V; 1.6 16V	04.98-08.03	K4J 714; K4J 750; K4M 700; K4M 701; K4M 704; K4M 708; (70-79kW)			544 0091 20	39
2.0; 2.0 i	01.96-08.03	F3R 750; F3R 751; F3R 752; F3R 791; F3R 796; F3R 797; F3R 798; (80-84kW)			544 0084 20	39

MEGANE II (BM0/1_, CM0/1_, KM0/1_, LM0/1_, EM0/1_)

1.4; 1.5 dCi; 1.6; 1.6 16V; 1.6 16V Hi-Flex; 1.6 Flex-Fuel	11.02-08.09	K4J 730; K4J 732; K4J 740; K4M 760; K4M 761; K4M 762; K4M 788; K4M 812; K4M 813; K4M 856; K9K 722; K9K 724; K9K 728; K9K 729; K9K 734; (60-83kW)			544 0090 20	39
1.4 16V	10.03-02.08	K4J 732; (60kW)		05.04→	544 0090 20	39
1.4 16V; 1.6	11.02-02.08	K4J 730; K4J 740; K4M 760; K4M 761; (72-83kW)		OPTION optional	544 0090 20	39

MEGANE III (EZ0/1_, DZ0/1_, BZ0_, KZ0/1)

1.2 TCe	03.12-	H5F 400; H5F 404; (85-97kW)		140128→, A/C	FB 7PK1570	42
				→01.14	FB 7PK1605	42
1.5 dCi; 1.6 16V Bifuel	11.08-	K4M 866; K9K 636; K9K 656; K9K 657; K9K 830; K9K 834; K9K 836; K9K 837; K9K 846; (63-81kW)			544 0090 20	39
1.6 dCi	04.11-	R9M 402; R9M 404; (96kW)			534 0624 10	38
2.0 CVT	02.09-	M4R 711; M4R 713; (103kW)		→08.15, M4R 711	529 0225 10	36
2.0 CVT	05.09-	M4R 711; M4R 713; (103kW)		→08.15	529 0225 10	36
2.0 CVT	05.09-	M4R 711; M4R 713; M4R F 713; (103kW)		→08.15, M4R 713	529 0225 10	36

MODUS / GRAND MODUS (F/JP0_)

1.4; 1.5 dCi; 1.5 dCi 75; 1.5 dCi 90; 1.6	09.04-	K4J 770; K4J 780; K4M 790; K4M 791; K4M 794; K4M 800; K4M 801; K9K 750; K9K 760; K9K 764; K9K 766; K9K 768; K9K 770; (48-82kW)			544 0090 20	39
---	--------	--	--	--	-------------	----

SAFRANE I (B54_)

2.0 12V; 2.2	04.92-07.96	J7R 734; J7R 735; J7T 760; J7T 761; J7T 762; (79-101kW)		A/C	FB 3PK890	40
--------------	-------------	---	--	-----	-----------	----

SCÉNIC I (JAO/1_)

1.4 16V	09.99-08.03	K4J 714; K4J 750; (70kW)			544 0091 20	39
---------	-------------	--------------------------	--	--	-------------	----

SCÉNIC II (JM0/1_) / SCÉNIC III (JZ0/1_)

1.2 TCe	04.12-	H5F 400; H5F 404; (85-97kW)		140128→, A/C	FB 7PK1570	42
				→01.14	FB 7PK1605	42
1.5 dCi; 1.6 16V; 1.6 E85; 1.6 Hi-Flex	06.03-07.10	K4M 766; K4M 812; K4M 813; K4M 858; K4M 866; K4M R 858; K9K 636; K9K 656; K9K 657; K9K 722; K9K 724; K9K 836; K9K 837; K9K 846; (60-82kW)			544 0090 20	39
1.6 dCi	04.11-	R9M 402; R9M 404; (96kW)			534 0624 10	38
2.0 16V	02.09-	M4R 710; M4R 711; M4R 713; (103kW)			529 0225 10	36

THALIA I (LB0/1/2_)

1.4; 1.4 16V	08.00-	K4J 712; K7J 700; (55-72kW)			544 0091 20	39
1.5 dCi	06.01-	K9K 700; K9K 702; K9K 714; K9K 740; (47-60kW)			544 0090 20	39

THALIA II (LU1/2_)

1.5 dCi	09.08-	K9K 718; (62kW)			544 0090 20	39
---------	--------	-----------------	--	--	-------------	----

TRAFIC II (FL, JL, EL)

1.9 dCi 100; 1.9 dCi 80; 1.9 dCi 80	03.01-	F9Q 760; F9Q 762; (60-74kW)		A/C	544 0101 20	39
-------------------------------------	--------	-----------------------------	--	-----	-------------	----

TRAFIC III Autobus/Autocar (JG_) / TRAFIC III Camionnette (FG_)

1.6 dCi 115; 1.6 dCi 120; 1.6 dCi 140; 1.6 dCi 145; 1.6 dCi 90; 1.6 dCi 95	05.14-	R9M 408; R9M 413; R9M 450; R9M 452; (66-107kW)			534 0624 10	38
--	--------	--	--	--	-------------	----

TWINGO II (CNO_)

1.5 dCi; 1.5 dCi 75; 1.5 dCi 90	03.07-	K9K 718; K9K 740; K9K 820; (47-63kW)			544 0090 20	39
---------------------------------	--------	--------------------------------------	--	--	-------------	----

ROVER

ROVER
75 (RJ, RJ)

2.0 CDT; 2.0 CDTi	02.99-05.05	204D2; M 47 R; (85-96kW)			A/C	529 0253 10	37
-------------------	-------------	--------------------------	--	--	-----	-------------	----

SAAB
9-5 (YS3G)

2.0 t BioPower; 2.0 t BioPower XWD; 2.0 Turbo; 2.0 Turbo XWD	05.10-01.12	A 20 NFT; A 20 NHT; (162kW)				FB 6PK1980	41
--	-------------	-----------------------------	--	--	--	------------	----

9-5 (YS3E, YS3E)

2.0 t; 2.0 t BioPower; 2.3 t; 2.3 t BioPower; 2.3 Turbo	09.97-12.09	B205E; B205L; B235E; B235L; B235R; (110-191kW)			A/C, AUTOM	FB 6PK1980	41
---	-------------	--	--	--	------------	------------	----

900 II

2.5 -24 V6	07.93-02.98	B258I; (125kW)			A/C, →MY 1996	FB 6PK2305	42
------------	-------------	----------------	--	--	---------------	------------	----

SEAT
ALHAMBRA (710, 711)

1.4 TSI	06.10-	CAVA; CNWB; CTHA; (110kW)			A/C	FB 6PK1700	41
---------	--------	---------------------------	--	--	-----	------------	----

EXEO (3R5, 3R2)

2.0 TDI	12.08-	CAGA; CJCA; (105kW)			A/C, CAGA	529 0239 10	36
2.0 TDI	12.08-	CAGC; CJCC; (88kW)			A/C, CAGC	529 0239 10	36
2.0 TDI	02.09-	CAHA; CGLB; (125kW)			A/C, CAHA	529 0239 10	36

IBIZA V (6J5, 6P1, 6J1, 6P5, 6J8, 6P8)

1.0	05.15-	CHYB; (55kW)			A/C, START/STOP	529 0160 10	36
					A/C, START/STOP	FB 6EPK989	41
1.4 TSI	06.09-	CAVF; CNUB; CTHF; CTJB; (110kW)			SUPERC, A/C, MANU	FB 6PK1700	41
1.4 TSI; 1.4 TSI Cupra	06.09-	CAVE; CAVF; CNUB; CTHE; CTHF; CTJB; CTJC; (110-132kW)			A/C	FB 6PK1700	41

Mii (KF1)

1.0	10.11-	CHYA; CHYB; (44-55kW)			A/C, START/STOP	529 0160 10	36
					A/C, START/STOP	FB 6EPK989	41

SKODA
CITIGO

1.0	10.11-	CHYA; CHYB; (44-55kW)			A/C, START/STOP	529 0160 10	36
					A/C, START/STOP	FB 6EPK989	41

FABIA (542, 545)

1.4 TSI RS	05.10-12.14	CAVE; CTHE; (132kW)			A/C	FB 6PK1700	41
------------	-------------	---------------------	--	--	-----	------------	----

FABIA (NJ3, NJ5)

1.0	08.14-	CHYA; CHYB; (44-55kW)			A/C, START/STOP	529 0160 10	36
					A/C, START/STOP	FB 6EPK989	41
1.6	01.15-	CWVA; (81kW)			A/C	529 0160 10	36
					A/C	FB 6EPK989	41

SMART
FORTWO Coupe / Cabrio (451, 451)

1.0	01.07-	M 132.910; (45kW)			A/C, BMW 451.334	529 0121 30	36
					A/C, Micro Hybrid Drive, BMW 451.334	FB 4EPK753	40
1.0	01.07-	M 132.910; (52kW)			A/C, BMW 451.380	529 0121 30	36
					A/C, Micro Hybrid Drive, BMW 451.380	FB 4EPK753	40
1.0; 1.0 Brabus; 1.0 Turbo; 1.0 Turbo Brabus	01.07-	M 132.910; M 132.930; (52-75kW)			A/C	529 0121 30	36
					A/C	FB 4EPK753	40
1.0 Brabus	04.12-	(88kW)			A/C	529 0121 30	36

SSANGYONG
ACTYON SPORTS II

2.0 Xdi; 2.0 Xdi 4WD	10.12-	D20DTR; (114kW)			A/C	FB 6PK1980	41
----------------------	--------	-----------------	--	--	-----	------------	----

KORANDO

2.0 e-XDi; 2.0 e-XDi 4WD	11.10-	D20DTF; (129kW)			A/C	FB 6PK1980	41
2.0 e-XDi; 2.0 e-XDi 4WD	02.12-	D20DT; D20DTF; (110kW)			A/C, D20DTR	FB 6PK1980	41

REXTON W

2.0 Xdi; 2.0 Xdi Traction intégrale	07.12-	D20DTR; (114kW)			A/C	FB 6PK1980	41
-------------------------------------	--------	-----------------	--	--	-----	------------	----

RODIUS II

2.0 Xdi; 2.0 Xdi 4WD	07.13-	D20DTR; (114kW)			A/C	FB 6PK1980	41
----------------------	--------	-----------------	--	--	-----	------------	----

TOYOTA
AURIS (E15)

1.33 Dual-VTi	01.10-09.12	1NR-FE; (73kW)			A/C	FB 6PK1250	41
---------------	-------------	----------------	--	--	-----	------------	----

TOYOTA
AURIS (_E15_)

1.4	03.07-09.12	4ZZ-FE; (71kW)			532 0799 10	38
1.4 D-4D	03.07-09.12	1ND-TV; (66kW)			544 0106 10	39

AURIS (_E18_)

1.4 D-4D	10.12-	1ND-TV; (66kW)			544 0106 10	39
----------	--------	----------------	--	--	-------------	----

AURIS TOURING SPORTS (_E18_)

1.4 D-4D	07.13-	1ND-TV; (66kW)			544 0106 10	39
----------	--------	----------------	--	--	-------------	----

AVENSIS T25 (_T25_, _T25_, _T25_)

1.6 VVT-i; 1.8	04.03-11.08	1ZZ-FE; 3ZZ-FE; (81-95kW)			532 0799 10	38
----------------	-------------	---------------------------	--	--	-------------	----

AVENSIS T22 (_T22_, _T22_, _T22_)

1.6; 1.6 VVT-i	10.00-02.03	3ZZ-FE; (81kW)			532 0799 10	38
----------------	-------------	----------------	--	--	-------------	----

AYGO (_B4_)

1.0	05.14-	1KR-FE; (51kW)		A/C	529 0262 10	37
				A/C	529 0268 10	38

COROLLA (_E11_)

1.6 16V	02.00-11.01	3ZZ-FE; (81kW)			532 0799 10	38
---------	-------------	----------------	--	--	-------------	----

COROLLA (_E12_)

1.6 VVT-i	01.02-12.06	3ZZ-FE; (81kW)			532 0799 10	38
-----------	-------------	----------------	--	--	-------------	----

COROLLA A trois volumes (_E18_, _ZRE17_)

1.4 D-4D	06.13-	1ND-TV; (66kW)			544 0107 10	40
----------	--------	----------------	--	--	-------------	----

COROLLA (_E12_, _E12_)

1.6 VVT-i	01.02-07.07	3ZZ-FE; (81kW)			532 0799 10	38
-----------	-------------	----------------	--	--	-------------	----

COROLLA Verso (_E12_)

1.6 VVT-i	01.02-05.04	3ZZ-FE; (81kW)			532 0799 10	38
-----------	-------------	----------------	--	--	-------------	----

LAND CRUISER (_J12_)

3.0 D-4D	09.02-07.09	1KD-FTV; (120-127kW)		A/C, pour véhicules sans chauffage électrique supplémentaire	FB 7PK1153	42
----------	-------------	----------------------	--	---	------------	----

LAND CRUISER (_J15_)

3.0 D-4D	08.09-	1KD-FTV; (127-140kW)		A/C, pas pour climat froid	FB 7PK1153	42
----------	--------	----------------------	--	----------------------------	------------	----

LAND CRUISER 90 (_J9_)

3.0 D-4D 4WD	08.00-08.02	1KD-FTV; (120kW)		A/C, pour véhicules sans chauffage électrique supplémentaire	FB 7PK1153	42
--------------	-------------	------------------	--	---	------------	----

MR III (ZZW3_)

1.8 16V VVT-i	10.99-06.07	1ZZ-FE; (103kW)			532 0799 10	38
---------------	-------------	-----------------	--	--	-------------	----

URBAN CRUISER (_P1_)

1.4 D-4D; 1.4 D-4D 4WD	01.09-04.14	1ND-TV; (66kW)			544 0106 10	39
------------------------	-------------	----------------	--	--	-------------	----

VERSO S (_P12_)

1.4 D4-D	11.10-10.16	1ND-TV; (66kW)			544 0106 10	39
----------	-------------	----------------	--	--	-------------	----

YARIS (_P1_)

1.0	04.99-09.05	1SZ-FE; (50kW)		→12.02, A/C,	532 0835 10	38
1.0	03.03-09.05	1SZ-FE; (48kW)		A/C,	532 0835 10	38
1.3	11.99-10.05	2NZ-FE; (63kW)		01.01→, 2SZ-FE, A/C,	532 0835 10	38
1.3	08.99-09.05	2SZ-FE; (64kW)		01.01→, A/C,	532 0835 10	38

YARIS (_P9_)

1.3 VVT-i	08.05-	2SZ-FE; (64kW)		11.05→, 2SZ-FE, A/C,	532 0835 10	38
1.4 D-4D	08.05-	1ND-TV; (66kW)			544 0106 10	39

YARIS (_P13_)

1.4 D-4D	09.11-	1ND-TV; (66kW)			544 0106 10	39
----------	--------	----------------	--	--	-------------	----

VAUXHALL
ASTRA Mk V (H) Sport Hatc, (H) Brea, (H) 3/5 porte

1.7 CDTi	01.04-10.12	A 17 DTJ; Z 17 DTJ; (81kW)		A/C	FB 6PK1250	41
----------	-------------	----------------------------	--	-----	------------	----

ZAFIRA Mk I (A) (F75)

1.6 CNG	09.01-06.05	Z 16 YNG; (71kW)		A/C	FB 5PK1210	40
---------	-------------	------------------	--	-----	------------	----

ZAFIRA Mk II (B) (M75)

1.7 CDTi	04.09-11.14	A 17 DTJ; Z 17 DTJ; (81kW)		A/C	FB 6PK1250	41
----------	-------------	----------------------------	--	-----	------------	----

VOLVO
850 (LS, LW)

2.3 Turbo R; 2.4 GLE	09.93-10.97	B 5234 T5; B 5254 T; (142-177kW)		A/C, AUTOM	FB 6PK1250	41
----------------------	-------------	----------------------------------	--	-------------	------------	----

C30

1.6	10.06-12.12	B 4164 S3; (74kW)		A/C	FB 5EPK868	40
1.8; 1.8 FlexFuel; 2.0; 2.0 FlexFuel	10.06-12.12	B 4184 S11; B 4184 S8; B 4204 S3; B 4204 S4; (92-107kW)		A/C	FB 5EPK705	40



VOLVO

S40 II (MS)

1.6	01.05-12.12	B 4164 S3; (74kW)		A/C	FB 5EPK868	40
1.8; 1.8 FlexFuel; 2.0; 2.0 F	04.04-12.12	B 4184 S11; B 4184 S8; B 4204 S3; B 4204 S4; (92-107kW)		A/C	FB 5EPK705	40

S60 I

2.4 D; 2.4 D5	05.01-04.10	D 5244 T2; D 5244 T4; D 5244 T5; D 5244 T7; (93-136kW)		 	 	529 0289 10 529 0290 10	38 38
2.4 D5	01.01-04.10	D 5244 T; (120kW)		 	 	529 0289 10 529 0290 10	38 38

S80 I (TS, XY)

2.4 D; 2.4 D5	08.01-07.06	D 5244 T; D 5244 T2; (96-120kW)		 	 	529 0289 10 529 0290 10	38 38
---------------	-------------	---------------------------------	--	------	------	----------------------------	----------

V50 (MW)

1.6	01.05-12.12	B 4164 S3; (74kW)		A/C	FB 5EPK868	40
1.8; 1.8 FlexFuel; 2.0; 2.0 FlexFuel	04.04-12.12	B 4184 S11; B 4184 S8; B 4204 S3; B 4204 S4; (92-107kW)		A/C	FB 5EPK705	40

V70 II (SW)

2.4 D	07.01-08.07	D 5244 T2; (96kW)		 	 	529 0289 10 529 0290 10	38 38
2.4 D; 2.4 D5; 2.4 D5 AWD	01.01-12.08	D 5244 T; D 5244 T4; D 5244 T5; D 5244 T7; (93-136kW)		 	 	529 0289 10 529 0290 10	38 38
2.4 D5 AWD	07.02-08.07	D 5244 T; D 5244 T2; D 5244 T5; (120kW)		 	 	529 0289 10 529 0290 10	38 38

V70 III (BW)

2.0 D	10.07-12.15	D 4204 T; (100kW)			FB 6PK1845	41
-------	-------------	-------------------	--	--	------------	----

V70 XC

2.4 D5 AWD; 2.4 D5 XC AWD	09.02-08.07	D 5244 T; D 5244 T4; (120-136kW)		 	 	529 0289 10 529 0290 10	38 38
2.4 T XC AWD	11.97-09.02	B 5254 T; (142kW)		 	 	FB 6PK1250 AUTOM	41

XC90 I

D3 / D5	04.09-12.14	D 5244 T5; (120kW)		 	 	529 0289 10 529 0290 10	38 38
D5 AWD	10.02-12.06	D 5244 T; D 5244 T5; (120kW)		 	 	529 0289 10 529 0290 10	38 38
D5 AWD	04.05-12.10	D 5244 T4; D 5244 T5; (120-136kW)		 	 	529 0289 10 529 0290 10	38 38
D5 AWD	01.11-12.14	D 5244 T18; (147kW)		 	 	529 0289 10 529 0290 10	38 38

VW

AMAROK (2H_, S1B)

2.0 BiTDI; 2.0 BiTDI 4motion	09.10-	CDCA; CNEA; CSHA; (120-132kW)		 	 	529 0240 10 529 0240 10	36 36
2.0 TDI; 2.0 TDI 4motion	09.10-	CDBA; CNFA; (90kW)		 	 	529 0240 10 529 0240 10	36 36
2.0 TDI; 2.0 TDI 4motion	06.12-	CNFB; (103kW)		 	 	529 0240 10 529 0240 10	36 36

BEETLE (5C1, 5C2, 5C7, 5C8)

1.4 TSI	10.11-	CAVD; CNWA; CTHD; CTKA; (118kW)		 	 	FB 6PK1700 A/C	41
---------	--------	---------------------------------	--	------	------	-------------------	----

EOS (1F7, 1F8)

1.4 TSI	05.08-08.15	CAVD; CTHD; (118kW)		 	 	FB 6PK1700 A/C	41
---------	-------------	---------------------	--	------	------	-------------------	----

GOLF V (1K1)

1.4 TSI	11.05-11.08	BLG; BMY; (103-125kW)		 	 	FB 6PK1700 A/C	41
---------	-------------	-----------------------	--	------	------	-------------------	----

GOLF V Variant (1K5)

1.4 TSI	06.07-07.09	BLG; BMY; CAVD; (103-125kW)		 	 	FB 6PK1700 A/C	41
---------	-------------	-----------------------------	--	------	------	-------------------	----

GOLF VI (5K1)

1.4 TSI	10.08-11.12	CAVD; CNWA; CTHD; CTKA; (118kW)		 	 	FB 6PK1700 A/C	41
---------	-------------	---------------------------------	--	------	------	-------------------	----







VW

GOLF VI Décapotable (517)						
1.4 TSI	03.11-	CAVD; CNWA; CTHD; CTKA; (118kW)		A/C	FB 6PK1700	41
GOLF VI Variant (AJ5)						
1.4 TSI	07.09-07.13	CAVD; CNWA; CTHD; CTKA; (118kW)		A/C	FB 6PK1700	41
GOLF PLUS (5M1, 521)						
1.4 TSI	05.06-12.13	BLG; BMY; CAVD; CNWA; (103-125kW)		A/C	FB 6PK1700	41
JETTA III (1K2)						
1.4 TSI	07.06-10.10	BLG; BMY; CAVD; (103-125kW)		A/C	FB 6PK1700	41
JETTA IV (162, 163)						
1.4 TSI	04.11-07.14	CAVA; CAVD; CTHA; CTHD; (110-118kW)		A/C	FB 6PK1700	41
LT II 28-35/46 (2DC, 2DF, 2DG, 2DL, 2DB, 2DE, 2DK, 2DA, 2DD, 2DH)						
2.5 SDI; 2.5 TDI	05.96-07.06	AGX; AHD; ANJ; APA; AVR; BBE; BBF; (55-80kW)			534 0011 10	38
MULTIVAN V (7HM, 7HN, 7HF, 7EF, 7EM, 7EN)						
2.0 BiTDI; 2.0 BiTDI 4motion; 2.0 TDI; 2.0 TDI 4motion	09.09-08.15	CAAA; CAAB; CAAC; CAAD; CAAE; CCHA; CCHB; CFCA; (62-132kW)		A/C	529 0240 10	36
MULTIVAN VI (SGF, SGM, SGN)						
2.0 TDI; 2.0 TDI 4motion	04.15-	CAAB; CAAC; CFCA; CXGB; (75-132kW)		A/C	529 0240 10	36
PHAETON (3D_)						
3.0 V6 TDI 4motion	09.04-05.07	BMK; (165kW)		WP, A/C,	FB 6PK2478	42
POLO (6R, 6C)						
1.0	01.14-	CHYA; CHYB; (44-55kW)		A/C, START/STOP	529 0160 10	36
				A/C, START/STOP	FB 6EPK989	41
1.6	07.14-	CWVA; CWVB; (66-81kW)		A/C	529 0160 10	36
				A/C	FB 6EPK989	41
SCIROCCO (137, 138)						
1.4 TSI	05.08-	CAVD; CNWA; CTHD; CTKA; (118kW)		A/C	FB 6PK1700	41
SHARAN (7N1, 7N2)						
1.4 TSI	05.10-	CAVA; CNWB; CTHA; (110kW)		A/C	FB 6PK1700	41
TOUAREG (7P5)						
3.0 V6 TDI	01.10-	CASA; CASD; CJMA; CNRB; CRCD; CVWA; (150-176kW)		CASA, CASB, CASD,	FB 6PK2478	42
3.0 V6 TDI	06.10-	CATA; (165kW)			FB 6PK2478	42
TOURAN (1T3, 1T1, 1T2)						
1.4 FSI; 1.4 TSI; 1.4 TSI EcoFuel	02.06-05.15	BLG; BMY; CAVB; CAVC; CDGA; CTHB; CTHC; (103-125kW)		A/C	FB 6PK1700	41
TRANSPORTER T4 (70XB, 70XC, 7DB, 7DW, 7DK, 70XA)						
2.5 TDI	05.98-04.03	AHY; AXG; (111kW)			534 0011 10	38
TRANSPORTER T5 (7HB, 7HJ, 7EB, 7EJ, 7EF, 7EG, 7HA, 7HH, 7EA, 7EH)						
2.0 BiTDI; 2.0 BiTDI 4motion; 2.0 TDI; 2.0 TDI 4motion	09.09-08.15	CAAA; CAAB; CAAC; CAAD; CAAE; CCHA; CCHB; CFCA; (62-132kW)		A/C	529 0240 10	36
TRANSPORTER V Camion plate-forme/Châssis (7JD, 7JE, 7JL, 7JY)						
2.0 BiTDI; 2.0 BiTDI 4motion; 2.0 TDI; 2.0 TDI 4motion	09.09-08.15	CAAA; CAAB; CAAC; CAAD; CFCA; (62-132kW)		A/C	529 0240 10	36
TRANSPORTER T6 (SGB, SGG, SGJ, SGA, SGH)						
2.0 TDI; 2.0 TDI 4motion	04.15-	CAAA; CAAB; CAAC; CFCA; CXGA; CXGB; (62-132kW)		A/C	529 0240 10	36
TRANSPORTER VI Camion plate-forme/Châssis (SFD, SFE, SFL, SF)						
2.0 TDI; 2.0 TDI 4motion	04.15-	CAAA; CAAB; CAAC; CFCA; CXGA; CXGB; (62-132kW)		A/C	529 0240 10	36
UP (121, 122, BL1, BL2)						
1.0	08.11-	CHYA; CHYB; (44-55kW)		A/C, START/STOP	529 0160 10	36
				A/C, START/STOP	FB 6EPK989	41



Liste numérique

529 0045 30	FIAT	8	FB 3PK875	NISSAN	14	FB 7PK1605	DACIA	7
529 0045 30	FORD	9	FB 3PK890	HONDA	10	FB 7PK1605	MAZDA	11
529 0045 30	LANCIA	11	FB 3PK890	LEXUS	11	FB 7PK1605	NISSAN	14
529 0121 30	SMART	20	FB 3PK890	RENAULT	19	FB 7PK1605	RENAULT	17, 18, 19
529 0152 10	HONDA	10	FB 5PK725	CITROËN	5, 7	FB 7PK1715	ALFA ROMEO	3
529 0160 10	SEAT	20	FB 5PK725	PEUGEOT	16, 17	FB 7PK1715	HONDA	9
529 0160 10	SKODA	20	FB 5PK985	AUDI	3, 4	FB 7PK1715	HYUNDAI	10
529 0160 10	VW	23	FB 5PK985	BENTLEY	4	FB 7PK1715	LANCIA	11
529 0225 10	RENAULT	18, 19	FB 5PK985	OPEL	15	FB 7PK1715	LAND ROVER	11
529 0233 10	MERCEDES-BENZ	12	FB 4EPK753	SMART	20	FB 7PK1855	BMW	4, 5
529 0239 10	AUDI	3, 4	FB 5EPK705	FORD	8, 9	FB 7PK1855	LAND ROVER	11
529 0239 10	SEAT	20	FB 5EPK705	VOLVO	21, 22	FB 7PK2285	HYUNDAI	10
529 0240 10	VW	22, 23	FB 5EPK868	FORD	8, 9	FB 7PK2285	JEEP	10
529 0242 10	AUDI	3	FB 5EPK868	VOLVO	21, 22	FB 7PK2285	KIA	11
529 0249 10	BMW	4, 5	FB 5PK1153	CITROËN	7	FB 7PK2285	MERCEDES-BENZ	13
529 0250 10	FORD	9	FB 5PK1153	HONDA	10	FB 7PK2672	INFINITI	10
529 0250 10	JAGUAR	10	FB 5PK1210	OPEL	15, 16	FB 7PK2672	LAND ROVER	11
529 0253 10	LAND ROVER	11	FB 5PK1210	VAUXHALL	21	FB 7PK2672	NISSAN	14
529 0253 10	MG	14	FB 5PK1370	MITSUBISHI	14	FB 7PK2683	FORD	9
529 0253 10	ROVER	20	FB 5PK1370	OPEL	15	FB 7PK2843	FORD	9
529 0254 10	BMW	4, 5	FB 6EPK989	SEAT	20	FB 8PK2093	LAND ROVER	11
529 0255 10	BMW	4, 5	FB 6EPK989	SKODA	20			
529 0256 10	CITROËN	5, 7	FB 6EPK989	VW	23			
529 0256 10	PEUGEOT	16, 17	FB 6PK1250	CHRYSLER	5			
529 0257 10	CITROËN	7	FB 6PK1250	DODGE	7			
529 0257 10	PEUGEOT	16	FB 6PK1250	OPEL	15, 16			
529 0258 10	CITROËN	5, 7	FB 6PK1250	TOYOTA	20			
529 0258 10	PEUGEOT	16	FB 6PK1250	VAUXHALL	21			
529 0259 10	CITROËN	5, 7	FB 6PK1250	VOLVO	21, 22			
529 0259 10	PEUGEOT	16	FB 6PK1503	FORD	8, 9			
529 0260 10	PEUGEOT	16	FB 6PK1700	AUDI	3			
529 0262 10	CITROËN	6	FB 6PK1700	SEAT	20			
529 0262 10	PEUGEOT	16	FB 6PK1700	SKODA	20			
529 0262 10	TOYOTA	21	FB 6PK1700	VW	22, 23			
529 0266 10	CITROËN	5, 6	FB 6PK1845	ALFA ROMEO	3			
529 0266 10	DS	8	FB 6PK1845	FIAT	8			
529 0266 10	PEUGEOT	16, 17	FB 6PK1845	FORD	9			
529 0268 10	CITROËN	6	FB 6PK1845	LANCIA	11			
529 0268 10	PEUGEOT	16	FB 6PK1845	VOLVO	22			
529 0268 10	TOYOTA	21	FB 6PK1915	FORD	9			
529 0272 10	NISSAN	14, 15	FB 6PK1980	CHEVROLET	5			
529 0289 10	VOLVO	22	FB 6PK1980	JEEP	10			
529 0290 10	VOLVO	22	FB 6PK1980	MERCEDES-BENZ	11, 12, 13			
532 0799 10	TOYOTA	21	FB 6PK1980	OPEL	15			
532 0835 10	TOYOTA	21	FB 6PK1980	SAAB	20			
534 0011 10	VW	23	FB 6PK1980	SSANGYONG	20			
534 0611 10	MERCEDES-BENZ	12, 14	FB 6PK1986	MERCEDES-BENZ	12			
534 0624 10	MERCEDES-BENZ	12, 13	FB 6PK2280	AUDI	3			
534 0624 10	NISSAN	14, 15	FB 6PK2280	FORD	9			
534 0624 10	OPEL	15	FB 6PK2280	JEEP	10			
534 0624 10	RENAULT	18, 19	FB 6PK2280	MERCEDES-BENZ	13			
535 0304 10	CITROËN	5, 6	FB 6PK2285	AUDI	3			
535 0304 10	DS	8	FB 6PK2285	ISUZU	10			
535 0304 10	PEUGEOT	16, 17	FB 6PK2285	JEEP	10			
535 0311 10	FIAT	8	FB 6PK2285	MAZDA	11			
535 0311 10	OPEL	15	FB 6PK2285	MERCEDES-BENZ	12, 13			
544 0079 20	CITROËN	5, 6, 7	FB 6PK2285	OPEL	15			
544 0079 20	FORD	8, 9	FB 6PK2285	PORSCHE	17			
544 0079 20	MAZDA	11	FB 6PK2305	CHEVROLET	5			
544 0079 20	MINI	14	FB 6PK2305	JAGUAR	10			
544 0079 20	PEUGEOT	16, 17	FB 6PK2305	MAZDA	11			
544 0084 20	RENAULT	18, 19	FB 6PK2305	SAAB	20			
544 0087 20	CITROËN	5, 6, 7	FB 6PK2478	AUDI	4			
544 0087 20	PEUGEOT	16, 17	FB 6PK2478	HYUNDAI	10			
544 0090 20	DACIA	7	FB 6PK2478	JEEP	10			
544 0090 20	NISSAN	14	FB 6PK2478	KIA	10			
544 0090 20	RENAULT	18, 19	FB 6PK2478	MERCEDES-BENZ	12, 13			
544 0091 20	RENAULT	18, 19	FB 6PK2478	PORSCHE	17			
544 0101 20	NISSAN	14	FB 6PK2478	VW	23			
544 0101 20	OPEL	15	FB 7PK1153	NISSAN	14			
544 0101 20	RENAULT	18, 19	FB 7PK1153	TOYOTA	21			
544 0106 10	TOYOTA	21	FB 7PK1570	DACIA	7			
544 0107 10	MITSUBISHI	14	FB 7PK1570	RENAULT	17, 18, 19			
544 0107 10	TOYOTA	21	FB 7PK1605	BMW	5			

										DAYCO	 CONTITECH	GATES
529 0045 30	534 0607 10	1	36									
	535 0063 10	1										
	538 0442 10	1										
	544 0029 10	1										
	FB 6PK1310	1										
529 0121 30	534 0541 10	1	36									
	538 0110 10	1										
	FB 4EPK753	1										
	FB 4PK800	1										
529 0152 10	532 0580 10	1	36								K027PK2060	
	534 0251 10	1										
	FB 7PK2061	1										
529 0160 10	531 0871 10	1	36									
	FB 6EPK989	1										
529 0225 10	534 0442 10	1	36					KPV199			K066PK1218	
	FB 6PK1218	1										
529 0233 10	534 0446 10	1	36									
	FB 6PK1986	1										
529 0239 10	532 0468 10	1	36								K016PK1583	
	534 0164 10	1										
	535 0124 10	1										
	FB 6PK1580	1										
529 0240 10	532 0468 10	1	36								K086PK1555	
	534 0164 10	1										
	535 0124 10	1										
	FB 6PK1555	1										
529 0242 10	532 0513 10	1	36								K026PK2413	
	534 0375 10	1										
	535 0130 10	1										
	FB 6PK2413	1										
529 0249 10	534 0505 10	1	36									
	535 0203 10	1										
	FB 6PK1780	1										
529 0250 10	534 0161 10	1	37						4PK735K1		K014PK738	
	FB 4PK735	1										
529 0253 10	531 0322 10	1	37								K015PK2030	
	531 0788 10	1										
	532 0363 20	1										
	534 0171 10	1										
	FB 5PK2030	1										
	FB 5PK875	1										
529 0254 10	532 0475 10	1	37						6PK1870K1		K116PK1873	
	534 0177 10	1										
	535 0075 10	1										
	FB 6PK1870	1										
529 0255 10	532 0475 10	1	37						6PK1870K1		K116PK1873	
	534 0177 10	1										
	535 0183 10	1										
	FB 6PK1870	1										
529 0256 10	531 0097 10	1	37					KPV013			K016PK1130	
	FB 6PK1130	1										
529 0257 10	532 0214 10	1	37					KPV175	6PK1564K2			
	534 0037 10	1										
	FB 6PK1565	1										
529 0258 10	531 0238 10	1	37					KPV030			K015PK778	
	FB 5PK775	1										
529 0259 10	531 0239 10	1	37					KPV034			K015PK963	
	FB 5PK963	1										
529 0260 10	531 0306 10	1	37					KPV107			K016PK1010	
	FB 6PK1010	1										
529 0262 10	534 0553 10	1	37									
	FB 6PK1203	1										
529 0266 10	534 0318 10	1	38					KPV222	6PK905EXTRAK1		K056PK905	
	FB 6PK905	1										
529 0268 10	534 0553 10	1	38									
	FB 6PK900	1										



Liste des Composants

		1 2 3 KIT				DAYCO		GATES
529 0272 10	532 0780 10	1	38					
	FB 7PK1145	1						
529 0289 10	532 0242 10	1	38					K066DPK1825
	534 0319 10	1						
	535 0072 10	1						
	FB 6DPK1825	1						
529 0290 10	531 0760 10	1	38					K046DPK1825
	532 0242 10	1						
	534 0047 10	1						
	535 0072 10	1						
	FB 6DPK1825	1						



0...			1...		
0019931796	MERCEDES-BENZ	FB 6PK2280	1372763	FORD	FB 7PK2683
0029932396	MERCEDES-BENZ	FB 6PK1986	1376084	FORD	FB 6PK2280
0029936096	MERCEDES-BENZ	FB 6PK1986	1376751	FORD	FB 7PK2683
0089978892	MERCEDES-BENZ	FB 6PK2285	1376752	FORD	FB 7PK2843
0109978992	MERCEDES-BENZ	FB 6PK2478	1440086	FORD	FB 7PK2683
0129971092	MERCEDES-BENZ	FB 6PK2285	1440434	FORD	FB 7PK2843
0129971192	MERCEDES-BENZ	FB 6PK2285	1471770	FORD	FB 6PK1845
0139974492	MERCEDES-BENZ	FB 7PK2285	1611279180	CITROËN	529 0266 10
0149971692	MERCEDES-BENZ	FB 7PK2285	1611279180	PEUGEOT	529 0266 10
03C260849A	SEAT	FB 6PK1700	1612373380	CITROËN	529 0262 10
03C260849A	SKODA	FB 6PK1700	1612373380	PEUGEOT	529 0262 10
03C260849A	VW	FB 6PK1700	1612373880	CITROËN	529 0268 10
04360111	SAAB	FB 6PK2305	1612373880	PEUGEOT	529 0268 10
04861733AC	CHRYSLER	FB 6PK1250	1729970092	SSANGYONG	FB 6PK1915
04C260849E	VW	FB 6EPK989	1761929	FORD	FB 6PK1503
059903137AC	AUDI	FB 6PK2478	1854733	ISUZU	FB 6PK2285
059903137AC	VW	FB 6PK2478	1854733	OPEL	FB 6PK2285
059903137R	AUDI	FB 6PK2478	1854733	VAUXHALL	FB 6PK2285
059903137R	VW	FB 6PK2478			
06E903137AA	AUDI	FB 6PK2285			
06E903137AE	AUDI	FB 6PK2478			
074145278D	VW	534 0011 10	252123C100	HYUNDAI	FB 6PK2478
074145278F	VW	534 0011 10	252123C100	KIA	FB 6PK2478
074145283	VW	534 0011 10	252123C200	HYUNDAI	FB 6PK2478
074145283B	VW	534 0011 10	252123C200	KIA	FB 6PK2478
074145299A	VW	534 0011 10	252124A000	HYUNDAI	FB 7PK2285
076145283	VW	534 0011 10	252124A000	KIA	FB 7PK2285
077903137H	AUDI	FB 6PK2478	252124A001	HYUNDAI	FB 7PK2285
077903137L	AUDI	FB 6PK2478	252124A001	KIA	FB 7PK2285
078903137C	AUDI	FB 6PK2280	252124A410	HYUNDAI	FB 7PK1715
09117585	OPEL	FB 5PK1210	252124A411	HYUNDAI	FB 7PK1715
			2669930096	MERCEDES-BENZ	FB 6PK1986
1...			2...		
11281736986	BMW	FB 7PK1605	252123C100	HYUNDAI	FB 6PK2478
11281742012	BMW	FB 7PK1605	252123C100	KIA	FB 6PK2478
11282365965	BMW	529 0249 10	252123C200	HYUNDAI	FB 6PK2478
11287568247	BMW	FB 7PK1855	252123C200	KIA	FB 6PK2478
11287570664	BMW	FB 7PK1855	252124A000	HYUNDAI	FB 7PK2285
11287628652	BMW	FB 7PK1855	252124A000	KIA	FB 7PK2285
11287628653	BMW	FB 7PK1855	252124A001	HYUNDAI	FB 7PK2285
11287636363	BMW	FB 7PK1605	252124A010	KIA	FB 7PK2285
1137008	FORD	FB 6PK1915	252124A410	HYUNDAI	FB 7PK1715
1172000Q5J	NISSAN	FB 7PK1605	252124A411	HYUNDAI	FB 7PK1715
1172000Q6L	NISSAN	FB 7PK1605	2669930096	MERCEDES-BENZ	FB 6PK1986
117202001R	RENAULT	FB 7PK1605			
117205167R	RENAULT	FB 7PK1605			
117205X20A	NISSAN	FB 7PK2672			
117205X29E	NISSAN	FB 7PK2672			
117206015R	RENAULT	FB 7PK1605			
117206170R	RENAULT	529 0225 10			
117209058R	DACIA	FB 7PK1570			
117209058R	RENAULT	FB 7PK1570			
11720JD00B	NISSAN	FB 7PK1153			
11720JD00C	NISSAN	FB 7PK1153			
117505337R	RENAULT	534 0624 10			
1195065F10	NISSAN	FB 3PK875			
1195065F12	NISSAN	FB 3PK875			
1195500Q0G	NISSAN	534 0624 10			
12605208	CHEVROLET	FB 6PK1980			
12605208	OPEL	FB 6PK1980			
12605208	SAAB	FB 6PK1980			
1340012	OPEL	FB 5PK1210			
1340016	OPEL	FB 5PK1210			
1340600	OPEL	FB 6PK1250			
1340635	OPEL	FB 5PK1210			
1340635	VAUXHALL	FB 5PK1210			
1340658	OPEL	FB 5PK1210			
1340658	VAUXHALL	FB 5PK1210			
1340733050	TOYOTA	544 0106 10			
1342417	OPEL	FB 6PK1980			
1346034	FORD	FB 5EPK705			
1357022010	TOYOTA	532 0799 10			
			3...		
			30650846	VOLVO	FB 5EPK868
			30777352	VOLVO	FB 6PK1845
			30777417	VOLVO	FB 5EPK705
			31110	HONDA	FB 7PK1715
			38920PWA506	HONDA	FB 5PK1153
			38920PWAJ01	HONDA	FB 5PK1153
			3M5Q6C301CB	VOLVO	FB 5EPK705
			3M5Q6D314CB	FORD	FB 5EPK705
			4...		
			46474062	LANCIA	FB 6PK1845
			4861733AA	CHRYSLER	FB 6PK1250
			4861733AC	CHRYSLER	FB 6PK1250
			4965687	SAAB	FB 6PK1980
			4M5Q6C301BB	FORD	FB 5EPK868
			5...		
			53008744	JEEP	FB 7PK2285
			53010289	JEEP	FB 7PK2285
			53010311	JEEP	FB 6PK1980
			53012002	JEEP	FB 6PK2285
			53054449	JEEP	FB 6PK2280
			55562418	OPEL	FB 5PK1210
			55562419	OPEL	FB 5PK1210
			56992PEJ004	HONDA	FB 3PK890
			56992PEJ505	HONDA	FB 3PK890
			56992PEJ506	HONDA	FB 3PK890
			575074	PEUGEOT	FB 5PK725
			5750P5	PEUGEOT	FB 5PK725
			5750P6	CITROËN	FB 5PK725
			5750TL	CITROËN	FB 5PK1153
			5750VVV	CITROËN	FB 5PK725
			6...		
			60595446	ALFA ROMEO	FB 7PK1715



Références OE

6...			A...		
60597794	ALFA ROMEO	FB 7PK1715	A0089977392	MERCEDES-BENZ	FB 6PK1980
60604835	ALFA ROMEO	FB 7PK1715	A0089978892	MERCEDES-BENZ	FB 6PK2285
60666950	ALFA ROMEO	FB 6PK1845	A0129971092	MERCEDES-BENZ	FB 6PK2285
60812513	FIAT	FB 6PK1845	A0129971192	MERCEDES-BENZ	FB 6PK2285
6340613	OPEL	FB 5PK1370	A1195065F10	NISSAN	FB 3PK875
6340626	OPEL	FB 5PK1210	A1195065F12	NISSAN	FB 3PK875
6340626	VAUXHALL	FB 5PK1210	A195065F12	NISSAN	FB 3PK875
6340627	OPEL	FB 5PK1210			
6340627	VAUXHALL	FB 5PK1210			
6340657	OPEL	FB 5PK1210			
6340657	VAUXHALL	FB 5PK1210			
6340671	OPEL	FB 6PK1250			
6719970192	SSANGYONG	FB 6PK1980			
6C1Q6C301EA	FORD	FB 6PK2280			
6C1Q6C301GB	FORD	FB 7PK2683			
6C1Q6C301GC	FORD	FB 7PK2683			
6C1Q6C301HB	FORD	FB 7PK2843			
6C1Q6C301HC	FORD	FB 7PK2843			
7...			C...		
7653808	HONDA	FB 3PK890	C2Z4780	JAGUAR	FB 6PK2305
7653808	LANCIA	FB 7PK1715	CM5Q6C301BA	FORD	FB 6PK1503
7700853838	RENAULT	FB 3PK890			
7700854495	RENAULT	FB 3PK890			
7701477107	RENAULT	529 0225 10			
7701477526	RENAULT	529 0225 10			
7701479107	RENAULT	529 0225 10			
7G9Q6C301CA	FORD	FB 6PK1845			
8...			L...		
8653641	VOLVO	FB 5EPK705	L33615909	MAZDA	FB 6PK2285
8844052010	TOYOTA	532 0835 10	L33615909A	MAZDA	FB 6PK2285
			L33615909B	MAZDA	FB 6PK2285
			L3B615909	MAZDA	FB 6PK2285
			L3C115909	MAZDA	FB 6PK2305
			L3C1159099F	MAZDA	FB 6PK2305
			L3R415909	MAZDA	FB 6PK2305
			L3R415909A	MAZDA	FB 6PK2305
			L3R415909B	MAZDA	FB 6PK2305
			L51015909B	MAZDA	FB 6PK2285
			LR031361	LAND ROVER	FB 7PK2672
9...			M...		
9091602640	TOYOTA	FB 7PK2285	MD338462	MITSUBISHI	FB 5PK1370
9091602708	TOYOTA	FB 7PK2285	MD374223	MITSUBISHI	544 0107 10
909602510	TOYOTA	FB 7PK1153			
9117585	OPEL	FB 5PK1210			
9117585	VAUXHALL	FB 5PK1210			
9117586	VAUXHALL	FB 5PK1210			
9128952	OPEL	FB 5PK1210			
9128952	VAUXHALL	FB 5PK1210			
91541144	PEUGEOT	FB 5PK725			
91541175	PEUGEOT	FB 5PK725			
9224370	OPEL	FB 5PK1210			
93169491	OPEL	FB 5PK1210			
93181316	OPEL	FB 5PK1210			
93181704	OPEL	FB 5PK985			
93185058	SAAB	FB 6PK2305			
95510293400	PORSCHE	FB 6PK2478			
95810221600	PORSCHE	FB 6PK2478			
96152090	CITROËN	FB 5PK1153			
96152091	CITROËN	FB 5PK1153			
97130560	ISUZU	FB 6PK2285			
97130560	OPEL	FB 6PK2285			
97130560	VAUXHALL	FB 6PK2285			
97186395	OPEL	FB 6PK1250			
97385845	OPEL	FB 6PK1250			
98MF6C301DA	FORD	FB 6PK1915			
9936300890	LEXUS	FB 3PK890			
9936300900	LEXUS	FB 3PK890			
99363208908P	LEXUS	FB 3PK890			
99367C2280	TOYOTA	FB 7PK2285			
99919237950	PORSCHE	FB 6PK2285			
A...			P...		
A0019931796	MERCEDES-BENZ	FB 6PK2280	PQS101490	LAND ROVER	FB 7PK1715
A0019934596	SMART	FB 4EPK753	PQS500370	LAND ROVER	FB 8PK2093
A0079978092	MERCEDES-BENZ	FB 6PK1980			



Correspondance des références

CONTITECH		CONTITECH		CONTITECH	
3PK875	FB 3PK875				
3PK890	FB 3PK890				
5PK725	FB 5PK725				
5PK985	FB 5PK985				
5PK1370	FB 5PK1370				
6PK1250	FB 6PK1250				
6PK1845	FB 6PK1845				
6PK1915	FB 6PK1915				
6PK1980	FB 6PK1980				
6PK2280	FB 6PK2280				
6PK2285	FB 6PK2285				
6PK2310	FB 6PK2305				
6PK2475	FB 6PK2478				
7PK1153	FB 7PK1153				
7PK1570	FB 7PK1570				
7PK1605	FB 7PK1605				
7PK1855	FB 7PK1855				
7PK2283	FB 7PK2285				
7PK2672	FB 7PK2672				
7PK2682	FB 7PK2683				
7PK2842	FB 7PK2843				
8PK2092	FB 8PK2093				
4PK735K1	529 0250 10				
6PK1564K2	529 0257 10				
6PK1870K1	529 0254 10				
4PK753ELAST	FB 4EPK753				
5PK705ELAST	FB 5EPK705				
5PK868ELAST	FB 5EPK868				
6PK989ELAST	FB 6EPK989				
6PK1502EXTRA	FB 6PK1503				
6PK1986EXTRA	FB 6PK1986				
6PK905EXTRAK1	529 0266 10				





Correspondance des références

DAYCO		DAYCO		DAYCO	
APV2849	532 0799 10				
APV3205	534 0624 10				
DPV1231	544 0106 10				
KPV013	529 0256 10				
KPV030	529 0258 10				
KPV034	529 0259 10				
KPV107	529 0260 10				
KPV175	529 0257 10				
KPV199	529 0225 10				
KPV222	529 0266 10				
3PK872	FB 3PK875				
3PK890	FB 3PK890				
5PK725	FB 5PK725				
5PK986	FB 5PK985				
6PK1250	FB 6PK1250				
6PK1700	FB 6PK1700				
6PK1915	FB 6PK1915				
6PK1980	FB 6PK1980				
6PK2280	FB 6PK2280				
6PK2285	FB 6PK2285				
6PK2475	FB 6PK2478				
7PK1153	FB 7PK1153				
7PK1605	FB 7PK1605				
7PK1715	FB 7PK1715				
7PK1853	FB 7PK1855				
7PK2285	FB 7PK2285				
7PK2682	FB 7PK2683				
7PK2842	FB 7PK2843				
8PK2092	FB 8PK2093				
5PK705EE	FB 5EPK705				
5PK868EE	FB 5EPK868				
6PK1985S	FB 6PK1986				





Correspondance des références

GATES		GATES	
3PK878	FB 3PK875		
3PK890	FB 3PK890		
5PK725	FB 5PK725		
5PK985	FB 5PK985		
5PK1153	FB 5PK1153		
5PK1210	FB 5PK1210		
5PK1368	FB 5PK1370		
6PK1250	FB 6PK1250		
6PK1503	FB 6PK1503		
6PK1700	FB 6PK1700		
6PK1845	FB 6PK1845		
6PK1915	FB 6PK1915		
6PK1980	FB 6PK1980		
6PK2285	FB 6PK2285		
6PK2305	FB 6PK2305		
6PK2478	FB 6PK2478		
7PK1153	FB 7PK1153		
7PK1570	FB 7PK1570		
7PK1605	FB 7PK1605		
7PK1715	FB 7PK1715		
7PK2285	FB 7PK2285		
7PK2683	FB 7PK2683		
7PK2843	FB 7PK2843		
8PK2093	FB 8PK2093		
5PK705SF	FB 5EPK705		
5PK868SF	FB 5EPK868		
K014PK738	529 0250 10		
K015PK778	529 0258 10		
K015PK963	529 0259 10		
K056PK905	529 0266 10		
6PK1986EMD	FB 6PK1986		
K015PK2030	529 0253 10		
K016PK1010	529 0260 10		
K016PK1130	529 0256 10		
K016PK1583	529 0239 10		
K026PK2413	529 0242 10		
K027PK2060	529 0152 10		
K066PK1218	529 0225 10		
K086PK1555	529 0240 10		
K116PK1873	529 0254 10		
K046DPK1825	529 0290 10		
K066DPK1825	529 0289 10		
T36448	532 0799 10		
T39251	534 0624 10		







Correspondance des références

SKF		SKF		SKF	
VKMV5PK725	FB 5PK725				
VKMV6PK1250	FB 6PK1250				
VKMV6PK1699	FB 6PK1700				
VKMV6PK1700	FB 6PK1700				
VKMV6PK1702	FB 6PK1700				
VKMV6PK1915	FB 6PK1915				
VKMV6PK2285	FB 6PK2285				
VKMV6PK2475	FB 6PK2478				
VKMV7PK1605	FB 7PK1605				
VKMV7PK2284	FB 7PK2285				
VKMV7PK2842	FB 7PK2843				
VKM36136	534 0624 10				
VKM61015	532 0799 10				
VKM61036	532 0835 10				
VKMA31127	529 0239 10				
VKMA31148	529 0240 10				
VKMA33025	529 0260 10				
VKMA33026	529 0257 10				
VKMA33045	529 0258 10				
VKMA33046	529 0259 10				
VKMA33202	529 0256 10				
VKMA33410	529 0266 10				
VKMA36110	529 0225 10				
VKMA38330	529 0254 10				
VKMA62076	529 0272 10				
VKMV5SK868	FB 5EPK868				





Correspondance des références

SNR 	SNR 	SNR 
GA35407 GA35528 GA36916	534 0011 10 534 0624 10 532 0835 10	



Illustrations

529 0045 30

[mm]
 6PK 1310
 M10 x 55

529 0121 30

[mm]
 4PK 800
 4PK 753

529 0152 10

[mm]
 7PK 2061

529 0160 10

[mm]
 6PK 989

529 0225 10

[mm]
 6PK 1218

529 0233 10

[mm]
 6PK 1986

529 0239 10

[mm]
 6PK 1580

529 0240 10

[mm]
 6PK 1555

529 0242 10

[mm]
 6PK 2413

529 0249 10

[mm]
 6PK 1780



<p>529 0250 10</p>  <p>[mm] AAA 4PK ↻ 735</p>	<p>529 0253 10</p>  <p>[mm] AAA 5PK ↻ 2030 AAA 5PK ↻ 869</p>
<p>529 0254 10</p>  <p>[mm] AAA 6PK ↻ 1870</p>	<p>529 0255 10</p>  <p>[mm] AAA 6PK ↻ 1870</p>
<p>529 0256 10</p>  <p>[mm] AAA 6PK ↻ 1130</p>	<p>529 0257 10</p>  <p>[mm] AAA 6PK ↻ 1565</p>
<p>529 0258 10</p>  <p>[mm] AAA 5PK ↻ 775</p>	<p>529 0259 10</p>  <p>[mm] AAA 5PK ↻ 963</p>
<p>529 0260 10</p>  <p>[mm] AAA 6PK ↻ 1010</p>	<p>529 0262 10</p>  <p>[mm] AAA 6PK ↻ 1203</p>



Illustrations

<p style="text-align: center;">529 0266 10</p> <p style="text-align: right;">[mm] 6PK 905</p>	<p style="text-align: center;">529 0268 10</p> <p style="text-align: right;">[mm] 6PK 900</p>
<p style="text-align: center;">529 0272 10</p> <p style="text-align: right;">[mm] 7PK 1145</p>	<p style="text-align: center;">529 0289 10</p> <p style="text-align: right;">[mm] 6PK 1825</p>
<p style="text-align: center;">529 0290 10</p> <p style="text-align: right;">[mm] 6PK 1825</p>	<p style="text-align: center;">532 0799 10</p> <p style="text-align: right;">[mm] 6PK</p>
<p style="text-align: center;">532 0835 10</p> <p style="text-align: right;">[mm] M10</p>	<p style="text-align: center;">534 0011 10</p> <p style="text-align: right;">[mm] 6PK</p>
<p style="text-align: center;">534 0611 10</p> <p style="text-align: right;">[mm] 26,0</p>	<p style="text-align: center;">534 0624 10</p> <p style="text-align: right;">[mm] 30,0</p>

<p style="text-align: center;">535 0304 10</p> <p style="text-align: right;">[mm] AAAA 6PK</p>	<p style="text-align: center;">535 0309 10</p> <p style="text-align: right;">[mm] AAAA 7PK</p>
<p style="text-align: center;">535 0311 10</p> <p style="text-align: right;">[mm] AAAA 6PK</p>	<p style="text-align: center;">544 0079 20</p> <p style="text-align: right;">[mm] AAAA 6PK M12x1.50x50</p>
<p style="text-align: center;">544 0084 20</p> <p style="text-align: right;">[mm] AAAA 6PK M12x1.25x45</p>	<p style="text-align: center;">544 0087 20</p> <p style="text-align: right;">[mm] AAAA 6PK M12x45</p>
<p style="text-align: center;">544 0090 20</p> <p style="text-align: right;">[mm] AAAA 6PK M14x68</p>	<p style="text-align: center;">544 0091 20</p> <p style="text-align: right;">[mm] AAAA 6PK M12x1.25x48</p>
<p style="text-align: center;">544 0101 20</p> <p style="text-align: right;">[mm] AAAA 6PK M12x1.25x48</p>	<p style="text-align: center;">544 0106 10</p> <p style="text-align: right;">[mm] AAAA 6PK</p>



Illustrations

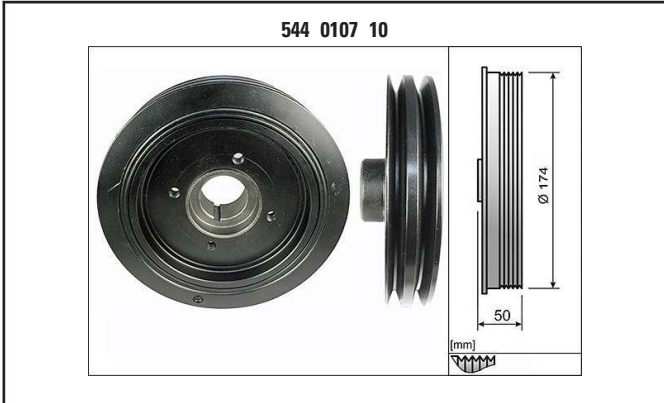

<p>FB 5PK985</p>	<p>FB 6EPK989</p>
<p>FB 6PK1250</p>	<p>FB 6PK1503</p>
<p>FB 6PK1700</p>	<p>FB 6PK1845</p>
<p>FB 6PK1915</p>	<p>FB 6PK1980</p>
<p>FB 6PK1986</p>	<p>FB 6PK2280</p>



Illustrations

