



**FAG**



## Completely maintenance-free

Maintenance-free high performance plain bearings  
in construction machinery

## Completely maintenance-free



Figure 1: Maintenance-free ELGES spherical plain bearings are available in various designs

**In excavator arms, articulation/swivel joints, wheel suspension arrangements or similar applications, most bearing positions in construction machinery are subjected to swivel motion with high loads.**

**Under such conditions, rolling bearings are only suitable in certain cases.**

**Where small swivel angles in particular are present and are combined with shocks and vibrations, false brinelling (stationary marks) may occur on the raceways. In addition to jerky running and increased noise, these frequently lead to premature bearing failure.**

### Plain bearings as an antidote

In order to avoid the resulting unnecessary downtime and costs, there has long been a proven alternative for these joints: plain bearings.

They are highly suitable not only for swivel motions. In the form of spherical plain bearings, they also allow tilting motion and can thus compensate misalignments.

### ELGES spherical plain bearings

For many years, the product range of the Schaeffler Group has included spherical plain bearings that, under the ELGES name, have been known to a wide circle of customers and used successfully in numerous applications.

ELGES spherical plain bearings are available in two designs:

- requiring maintenance
- maintenance-free.

In both cases, a distinction is made between spherical plain bearings of

radial, angular contact and axial design. All of these designs are standardised in accordance with DIN ISO 12 240 and are available in several dimension series. The range is supplemented by maintenance-free cylindrical plain bushes.

### Sliding layer between the rings

In the bearings requiring maintenance, the steel rings are separated at the contact surface by grease (and more rarely by oil). In the maintenance-free design, in contrast, there is a sliding layer 0,5 mm thick between the rings that is named ELGOGLIDE®.

### Sliding layer ELGOGLIDE®

ELGOGLIDE® is a sliding layer comprising PTFE fabric, Figure 2. PTFE stands for polytetrafluoroethylene and commonly known by the Dupont brand name Teflon®. The PTFE fabric is embedded in resin and bonded by adhesive to the outer ring. The mating raceway has a hard chromium coating.

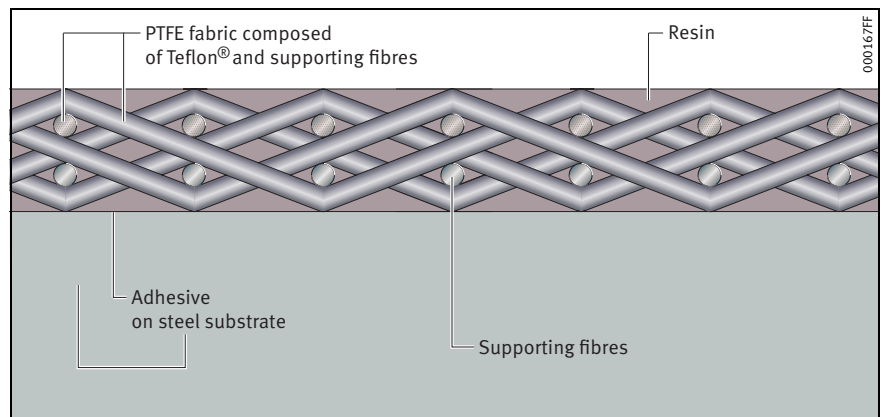

Figure 2: Composition of an ELGOGLIDE® sliding layer

The sliding material does not undergo swelling, does not weld to metals and is substantially resistant to chemical influences. It is equally suitable for rotary and linear motion. Its advantages come particularly into play, however, in the case of oscillating motion.

In summary: ELGOGLIDE® plain bearings have high load carrying capacity, exhibit excellent wear and friction behaviour and are impressive for their outstanding dry running characteristics. Against all the indisputable advantages, however, a few particular factors must be observed: ELGOGLIDE® bearings must not, under any circumstances, come into contact with lubricants of any type and must not be exposed to contamination or water. In this respect, they differ from the maintenance-free plastic plain bearings commonly available on the market, which can additionally be lubricated. For these restrictive conditions, however, there are remedies in the form of effective and reliable seals. For the tough operating conditions in construction machinery, the NBR sealing

rings (design 2RS) integrated in the bearing are not generally sufficient. Their function should be seen more in terms of retaining the sliding layer particles in the bearing.

Since construction machinery differs widely in design and there are differences between the specific bearing positions, it is not possible to make generally valid recommendations on sealing.

In order to determine the optimum sealing concept for a bearing position, the know-how available from Schaeffler Application Engineering, Construction Machinery should be requested and implemented in all cases. Advice and development resources geared to specific customers and applications is available worldwide via a global network of External Sales Engineers and Sales Offices as well as more than 30 Engineering Centres.

The table shows a comparison of the most important performance characteristics relating to those bearings requiring maintenance and maintenance-free bearings.

## Areas of application

Construction machinery is increasingly being chartered since smaller construction contractors in particular are reluctant to pay high purchase costs. In this case, it is obvious that charter companies require a significant reduction in downtime resulting from maintenance. Their interest is ultimately in making their machinery available at numerous construction sites as quickly as possible and without forced interruptions as a result of maintenance.

Other criteria receiving an increasing amount of attention include the reduction of lubricant and maintenance costs as well as environmental compatibility, as the escape of grease is no longer permissible.

All these requirements have been fulfilled by ELGOGLIDE® spherical plain bearings for many years in numerous installations, as shown in the following examples.

## Articulation/swivel joint

In wheeled loaders and road rollers, the steering function is often achieved by means of an articulated joint arranged between the front and rear axle. In this case, ELGOGLIDE® spherical plain bearings are an elegant solution that allow the required swivel motion about the vertical axis. Where oscillating motion is necessary about the horizontal

	Steel/steel	ELGOGLIDE®
Maximum sliding speed	100 mm/s	296 mm/s
Maximum dynamic contact pressure	100 N/mm <sup>2</sup>	300 N/mm <sup>2</sup>
Maximum static contact pressure	500 N/mm <sup>2</sup>	500 N/mm <sup>2</sup> (ZGB 300 N/mm <sup>2</sup> )
(p · v) <sub>max</sub>	400 N/mm <sup>2</sup> · mm/s	2 200 N/mm <sup>2</sup> · mm/s
Coefficient of friction μ	0,08 to 0,22	0,02 to 0,20

axis in order to compensate for unevenness in the terrain, this can be achieved on a similar basis using spherical plain bearings. *Figure 3* shows a typical articulation/swivel joint with two adjusted angular contact spherical plain bearings per axis of rotation.

### Lift mast

The lift mast for a wheeled loader as shown in *Figure 4* includes numerous joints. It is no rarity to find 20 or more bearing positions in such an application.

The product ELGOGLIDE® ZGB is virtually intended for this application. These cylindrical plain bushes with ELGOGLIDE® have proved effective here as a substitute for steel or bronze bushes with a relubrication facility. Upon request, the Schaeffler Group can also supply ready-to-fit bush/pin systems with

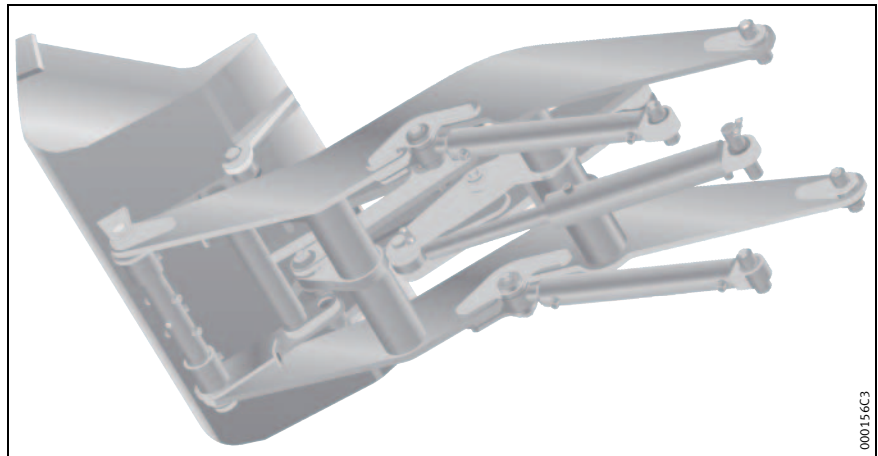

*Figure 4:* Lift mast for a wheeled loader

a clamping device, *Figure 5*. In addition to the advantage of rapid mounting, this ensures that the raceway of the pin fulfils the specification in order to form an optimum unit with the sliding layer. When pressed into the housing and frame, these units require no additional means of axial location.



*Figure 5:* Cylindrical plain bushes with ELGOGLIDE®



*Figure 3:* Articulation/swivel joint with ELGES spherical plain bearings

### Side dumper

In side dumpers and similar heavy duty off-road vehicles, the wheels normally have individual suspension mounting systems. A combination of wishbones and joints allows oscillating motions in order to compensate for unevenness in the terrain. The predominant conditions in the joints are such that they are almost made for ELGOGLIDE® bearings.

A unilateral load direction and very small swivel angles are unfavourable for steel/steel spherical plain bearings,

so the maintenance-free sliding layer is at a clear advantage here.

### Hydraulic cylinder

A classic example of a spherical plain bearing application is the hydraulic cylinder which normally has a radial spherical plain bearing requiring maintenance at each end connected to the adjacent parts. In this case, steel/steel bearings requiring maintenance are used predominantly while the maintenance-free ELGOGLIDE® bearings are still in the minority.

There are several reasons for this situation. In hydraulic cylinders, alternating loads and sufficiently large swivel angles are present.

Both of these fulfil the preconditions for the suitability of steel/steel bearings. Furthermore, a rim of grease is formed

during relubrication that deters contamination and, as a result, expensive sealing arrangements are not necessary. This also has the effect of reducing the resulting costs. This is at least the case at first glance.

For some time, increased awareness of environmental concerns as well as the possibility of reducing lubricant and maintenance costs have been indicating a trend towards maintenance-free ELGOGLIDE® bearings. Since the spherical plain bearings are designed in accordance with recognised standards, steel/steel bearings can be replaced without any problems by ELGOGLIDE® products of the same dimensions.

The use of ELGES bearings can thus be simplified by the use of rod ends designed as ready-to-fit components.

### Summary

Under the brand name ELGOGLIDE®, the Schaeffler Group offers a high performance, maintenance-free plain bearing that has proved effective on frequent occasions as both a spherical plain bearing or a plain bush. ELGOGLIDE® bearings are the ideal choice for users who place value on ease of mounting, absolute freedom from maintenance and environmental protection.

The main benefit lies in the reduction in maintenance costs and the minimisation of the resulting downtime periods. In many applications where steel/steel bearings would be subjected to excessive load, the high performance fabric ELGOGLIDE® makes it possible to use plain bearings.

Comprehensive information on ELGOGLIDE® bearings and mounting examples are given in the plain bearing catalogue 238, which can be requested from Schaeffler Group Application Engineering, Construction Machinery. This department can also carry out advisory work on an individual basis and matched to specific applications.

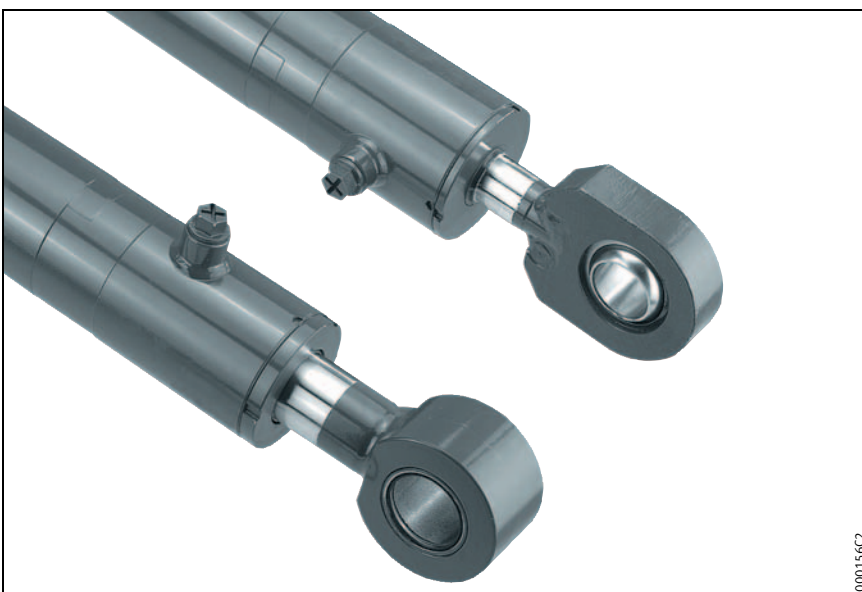

Figure 6: Hydraulic cylinder

000156C2



**Your contact**

Norbert Betten

Telephone +49 9132 82-1563

e-mail

[norbert.betten@schaeffler.com](mailto:norbert.betten@schaeffler.com)

**Schaeffler Technologies  
GmbH & Co. KG**

Industriestraße 1 – 3

91074 Herzogenaurach (Germany)