

Engine  
Chassis  
**Transmission**  
E-Mobility

**SCHAEFFLER**

# Lightweight Differential



# Lightweight Differential Optimized for Transverse Transmissions

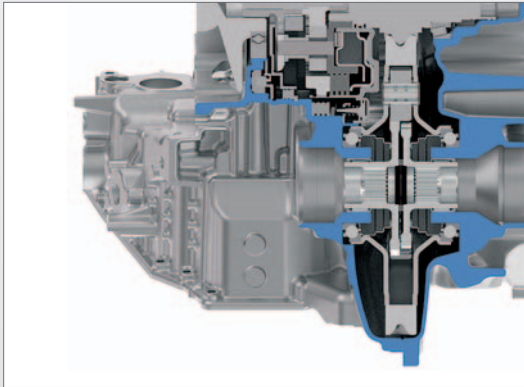

## Description

- Differential with lightweight design based on cold forming technology

## Functional advantages

- Optimized design envelope for clutches, torque converters, and universal joints
- Design with high rigidity to reduce NVH effects on the drive wheel
- Optimized lubrication of the plain bearings inside the differential
- Modular system for different torque classes

## Product benefits

- Lower weight compared to the standard
- Improved fuel consumption
- Reduced CO<sub>2</sub> emissions in the powertrain

## Integration/installation

- Optimized for transverse transmission applications, irrespective of design and torque

