

Engine
Chassis
Transmission
E-Mobility

SCHAEFFLER

Permanently Engaged Starter with Wrap Spring

IN THE REGION FOR THE REGION



Starter with Wrap Spring for Automatic Transmissions

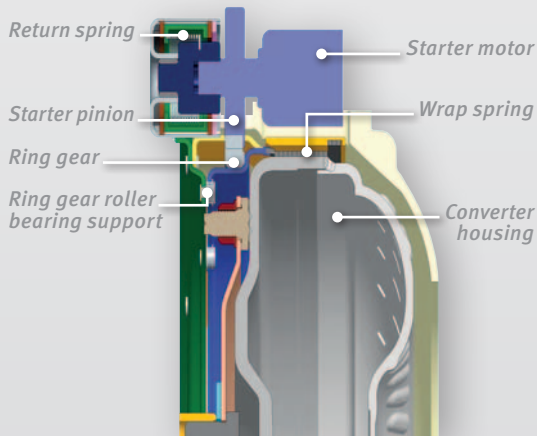
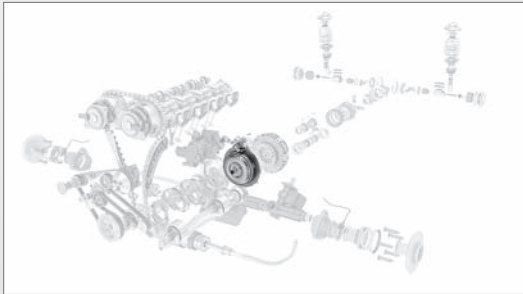

Description

- System for a permanently engaged starter (PES) with a wrap-around band for use with automatic transmission applications

Functional advantages

- One-way clutch prevents system losses during normal driving operation
- Highly efficient package – requires no additional space in the drive train
- Allows dynamic and quiet engine restarts, particularly during change-of-mind events

Product benefits

- Reduction of emissions
- System is cost effective compared to solutions currently available on the market

Integration/assembly efforts

- Arranged directly on the torque converter, almost no modifications to the bell housing or torque converter are required
- Drop-in module – can be assembled with the torque converter at the transmission plant